

TABLE OF CONTENTS

<u>Section</u>	<u>Page</u>
1.0 PURPOSE AND APPLICABILITY	1
2.0 RESPONSIBILITIES	1
2.1 Program Manager	1
2.2 Project Manager	1
2.3 Field Specialist	2
2.4 Data Analyst	2
2.5 Local (On-Site) Contact	2
3.0 REQUIRED EQUIPMENT AND MATERIALS	3
3.1 Equipment and Materials Required for Nephelometer Installations	3
3.2 Equipment and Materials Required for Transmissometer Installations	3
4.0 METHODS	5
4.1 Site Preparation and Communication	5
4.2 Installation Methods and Procedures	6
4.3 Operator Training	6
4.4 Site Documentation and Documentation Archival	6

1.0 PURPOSE AND APPLICABILITY

This standard operating procedure (SOP) outlines the general procedures regarding installation and site documentation of optical monitoring instrumentation operated according to IMPROVE Protocol. Optical monitoring sites include those equipped with an Optec LPV transmissometer and/or Optec NGN nephelometer.

To assure quality data capture and minimize data loss, site installation and documentation procedures include:

- Installing the instrumentation, shelters, and support components in a standard configuration to ease data collection, troubleshooting, and servicing.
- Performing thorough on-site specification measurements.
- Documenting site specification measurements and other site-related information.

The following technical instructions provide detailed information regarding installing optical monitoring equipment or documenting optical site information:

- TI 4070-3000 *Installation of Optec NGN-2 Nephelometer Systems (IMPROVE Protocol)*
- TI 4070-3001 *Site Documentation for Optec NGN-2 Nephelometer Systems*
- TI 4070-3010 *Installation and Site Documentation for Optec LPV-2 Transmissometer Systems (IMPROVE Protocol)*

2.0 RESPONSIBILITIES

2.1 PROGRAM MANAGER

The program manager shall review site preparation, installation requirements, and the installation schedule with the project manager.

2.2 PROJECT MANAGER

The project manager shall:

- Review site preparation, installation requirements, and the installation schedule with the program manager and/or the project-specific Contracting Officer's Technical Representative (COTR) as required.
- Schedule the system installation.
- Review final site configuration plans presented by the field specialist.
- Review the completed site documentation forms for completeness and accuracy.

2.3 FIELD SPECIALIST

The field specialist shall:

- Review the installation with the project manager.
- Coordinate with on-site personnel regarding the installation location, schedule, installation assistance, and availability of materials.
- Ship all required equipment to the site.
- Install the optical systems.
- Perform an installation calibration or field audit.
- Schedule and conduct an operator training session.
- Complete all site documentation.
- Provide completed site documentation to the data analyst.

2.4 DATA ANALYST

The data analyst shall:

- Verify transmission of data from the system upon completion of the installation.
- Enter all site documentation into the Quality Assurance Database.
- File all hard copy site documentation provided by the field specialist.

2.5 LOCAL (ON-SITE) CONTACT

The local contact shall:

- Review site preparation and installation requirements with the field specialist.
- Identify and contact local landowners, land managers, primary contacts, and site operators regarding site installation and routine maintenance requirements.
- Perform or ensure completion of any site preparation required prior to the installation.
- Assist in obtaining any site-, installation-, and regular servicing-related clearances and permits.
- Provide on-site equipment and tools required during the installation.
- As required, provide assistance with the installation.
- Schedule the operator training session with pertinent routine servicing personnel and the field specialist.

3.0 REQUIRED EQUIPMENT AND MATERIALS

3.1 EQUIPMENT AND MATERIALS REQUIRED FOR NEPHELOMETER INSTALLATIONS

- Optec NGN-2 ambient nephelometer with extra lamps
- Rohn tower, base plate, and hardware
- Solar radiation and precipitation shield
- Precipitation hood
- Nephelometer datalogging and support subsystem
- Span gas calibration system
- Ambient air temperature and relative humidity sensor in force-aspirated shield
- AC power line and telephone line
- Complete set of installation tools
- A camera loaded with color print film
- Laptop computer equipped with PROCOMM
- Replacement connector kit
- Telephone line simulator
- Topographic maps of the area
- Information documented during the site selection process
- NGN-2 Nephelometer Site Documentation Form
- Site Operator's Manual for Nephelometer Systems
- Complete set of standard operating procedures and technical instructions regarding annual site visit procedures, calibration of monitoring systems, replacing and shipping optical components, monitoring system diagrams, site documentation, and operator maintenance procedures
- Pen or pencil

3.2 EQUIPMENT AND MATERIALS REQUIRED FOR TRANSMISSOMETER INSTALLATIONS

- Installation transmissometer with calibrated lamps

- Audit transmissometer with calibrated lamps
- Programmed data collection platform (DCP) with antenna, antenna cable, and solar panel charging system or AC-trickle charger
- AT/RH sensor with housing and cable
- Strip chart recorder and supplies
- Electronic distance meter (EDM) with mirror assembly and tripods
- Receiver and transmitter shelters with anchor assemblies
- Receiver and transmitter mounting posts and alti-azimuth bases
- Window/hood assemblies
- Terminal strip board
- Power supplies and/or solar panel assemblies
- Metal shelves for larger shelters
- Shelter anchor assemblies
- Deep-cycle batteries for solar-powered installations
- Hardware for shelter assembly, post installation, and miscellaneous installation-related tasks
- Miscellaneous servicing supplies, as detailed in TI 4115-3000, *Annual Site Visit Procedures for Optec LPV-2 Transmissometer Systems (IMPROVE Protocol)*, TI 4110-3100, *Routine Site Operator Maintenance Procedures for LPV-2 Transmissometer Systems (IMPROVE Protocol)*, and TI 4110-3300, *Troubleshooting and Emergency Maintenance Procedures for Optec LPV-2 Transmissometer Systems (IMPROVE Protocol)*
- Concrete mix
- Caulking
- Rock/concrete epoxy capsules
- Surge protectors
- Solar panel regulators
- Dust pan, brushes, and broom
- AC or battery jigsaw with wood and metal blades

- AC or battery hammer drill with 5/8" hammer bit
- Hand sledge hammer and 5/8" star drill
- Wheelbarrow
- Wood saw
- Topographic maps of the area
- Ruler and protractor
- Photographs of sites, sight path, shelters, equipment configurations, etc.
- Information documented during the site selection process
- Transmissometer Site Description Sheet
- Site Map and Site Specifications Sheet
- Site Operator's Manual for Transmissometer Monitoring Systems
- Complete set of standard operating procedures and technical instructions regarding annual site visit procedures, calibration of monitoring systems, replacing and shipping optical components, monitoring system diagrams, site documentation, and operator maintenance procedures
- Pen or pencil

4.0 METHODS

This section includes four (4) major subsections that describe installation and documentation procedures applied to optical instruments:

- 4.1 Site Preparation and Communication
- 4.2 Installation Methods and Procedures
- 4.3 Operator Training
- 4.4 Site Documentation and Documentation Archival

4.1 SITE PREPARATION AND COMMUNICATION

Site preparation includes reviewing installation requirements with the local contact and scheduling all site preparation activities, including obtaining permission from landowners to access the monitoring location, determining site operators, and ensuring that all other necessary installation assistance is obtained.

The project manager schedules a site installation visit. The field technician schedules assistance from on-site personnel (such as obtaining required tools and equipment) and an operator training session.

4.2 INSTALLATION METHODS AND PROCEDURES

Nephelometer systems require installation of a tower, the nephelometer (with solar radiation and precipitation shield, precipitation hood, and AT/RH sensor) and support system components (datalogging and control subsystem, and span gas calibration system). Specific installation requirements are detailed in TI 4100-3375, *Replacing and Shipping Nephelometer System Components*. In addition, AC line power and a telephone line must be connected. After installation of the instrumentation, the entire system operation must be calibrated and verified.

Transmissometer systems require installation of shelters for both the transmitter and receiver units, mounting posts, the specific transmissometer components (transmitter and receiver) and support system components (alti-azimuth bases, terminal strip, AT/RH sensor, DCP and antenna, and strip chart recorder). Specific installation requirements are detailed in TI 4110-3375, *Replacing and Shipping Transmissometer Components*. In addition, either AC line power or DC solar power installation is required. After installation of the instrumentation, the entire system operation must be verified, and sight path distance measured.

4.3 OPERATOR TRAINING

Upon completion of the optical installation and system operation verification, all operators, back-up operators, and any other involved or interested on-site personnel are trained according to the procedures in TI 4115-3000, *Annual Site Visit Procedures for Optec LPV-2 Transmissometer Systems (IMPROVE Protocol)* or TI 4115-3005, *Annual Site Visit Procedures for Optec NGN-2 Nephelometer Systems (IMPROVE Protocol)*. Operators are trained in an overview of the monitoring program, instrument function and theoretical operation, component overview, routine servicing, and troubleshooting procedures. The site operator's manual for the appropriate instrumentation is reviewed and a copy is left with the site operators.

4.4 SITE DOCUMENTATION AND DOCUMENTATION ARCHIVAL

The field specialist completes site documentation including a site visit trip report, site specifications, geographic reference including landmarks, and location of monitoring equipment. Photographic documentation is also collected of the instrumentation.

QUALITY ASSURANCE/QUALITY CONTROL DOCUMENTATION SERIES	
TITLE	INSTALLATION OF OPTEC NGN-2 NEPHELOMETER SYSTEMS (IMPROVE PROTOCOL)
TYPE	TECHNICAL INSTRUCTION
NUMBER	4070-3000
DATE	JUNE 1995

AUTHORIZATIONS		
TITLE	NAME	SIGNATURE
ORIGINATOR	Ivar J. Rennat	
PROJECT MANAGER	James H. Wagner	
PROGRAM MANAGER	David L. Dietrich	
QA MANAGER	Gloria S. Mercer	
OTHER		

REVISION HISTORY			
REVISION NO.	CHANGE DESCRIPTION	DATE	AUTHORIZATIONS
1.0	Added respon's and site preparation steps.	July 1996	

TABLE OF CONTENTS

<u>Section</u>	<u>Page</u>
1.0 PURPOSE AND APPLICABILITY	1
2.0 RESPONSIBILITIES	3
2.1 Program Manager	3
2.2 Project Manager	3
2.3 Field Specialist	3
2.4 Data Analyst	4
2.5 Local (On-Site) Contact	4
3.0 REQUIRED EQUIPMENT AND MATERIALS	4
4.0 METHODS	5
4.1 Site Preparation and Communication	5
4.2 Installing the Tower	6
4.3 Installing the Solar Radiation and Precipitation Shield	8
4.4 Installing the Precipitation Hood	8
4.5 Installing the Nephelometer	11
4.6 Installing the Datalogging and Control Subsystem	12
4.7 Installing the Rotronics AT/RH Sensor and Force-Aspirated Shield	14
4.8 Installing the Span Gas Calibration System	17
4.9 Connecting the AC Power	17
4.10 Connecting the Telephone Line	19
4.11 Completing the Operational Verification and Installation Checklist	20
4.12 Calibrating the Nephelometer	23
4.13 Site Documentation	24
4.14 Photographic Documentation	24
4.15 Operator Training	24
4.16 Completing Routine Site Operator Maintenance	25

LIST OF FIGURES

<u>Figure</u>	<u>Page</u>
1-1 Typical Optec NGN-2 Nephelometer Station	2
4-1 Nephelometer Tower Components	7
4-2 Solar Radiation and Precipitation Shield Assembly	9
4-3 Precipitation Hood Installation Diagram	10
4-4 Nephelometer Exterior Diagram	11
4-5 Datalogging and Support Subsystem Component Diagram	13

LIST OF FIGURES (CONTINUED)

<u>Figure</u>		<u>Page</u>
4-6	Datalogging and Control Subsystem Connector Panel Diagram (Viewed From Inside the Enclosure)	15
4-7	Rotronics AT/RH Sensor in Force-Aspirated Shield	16
4-8	Span Gas Calibration System	18
4-9	Nephelometer Installation Checklist	21

LIST OF TABLES

<u>Table</u>		<u>Page</u>
4-1	Datalogging and Control Subsystem Connector Panel Description	15

1.0 PURPOSE AND APPLICABILITY

This technical instruction (TI) describes the procedures for installing Optec NGN-2 nephelometer stations operated according to IMPROVE Protocol. The purpose of this TI is also to assure quality data capture and minimize data loss by installing the instrumentation and support components in a standard configuration to ease data collection, troubleshooting, and servicing.

Figure 1-1 is an annotated photograph of a standard nephelometer station. The major station components are:

- Four meter Rohn tower (14 feet total - two 7 foot sections)
- Tower base plate
- Tower hardware (guy wires, clamps, etc.)
- Solar radiation and precipitation shield
- Precipitation hood
- Optec NGN-2 ambient nephelometer
- Nephelometer datalogging and support subsystem
- Span gas calibration system
- Rotronics MPF-100 ambient air temperature and relative humidity sensor in force-aspirated shield
- AC power line
- Telephone line (at sites without cellular telephone access)

Although nephelometer station configurations typically consist of the same major components, individual installations may vary considerably from the standard tower mount configuration described in this TI.

This TI is referenced from Standard Operating Procedure (SOP) 4070, *Installation and Site Documentation for Optical Monitoring Equipment*. The following SOPs and TIs are referenced in this document:

- TI 4070-3001 *Site Documentation for Optec NGN-2 Nephelometer Systems*
- TI 4100-3100 *Routine Site Operator Maintenance Procedures for Optec NGN-2 Nephelometer Systems (IMPROVE Protocol)*
- TI 4100-3350 *NGN-2 Nephelometer Monitoring System Diagrams and Component Descriptions*

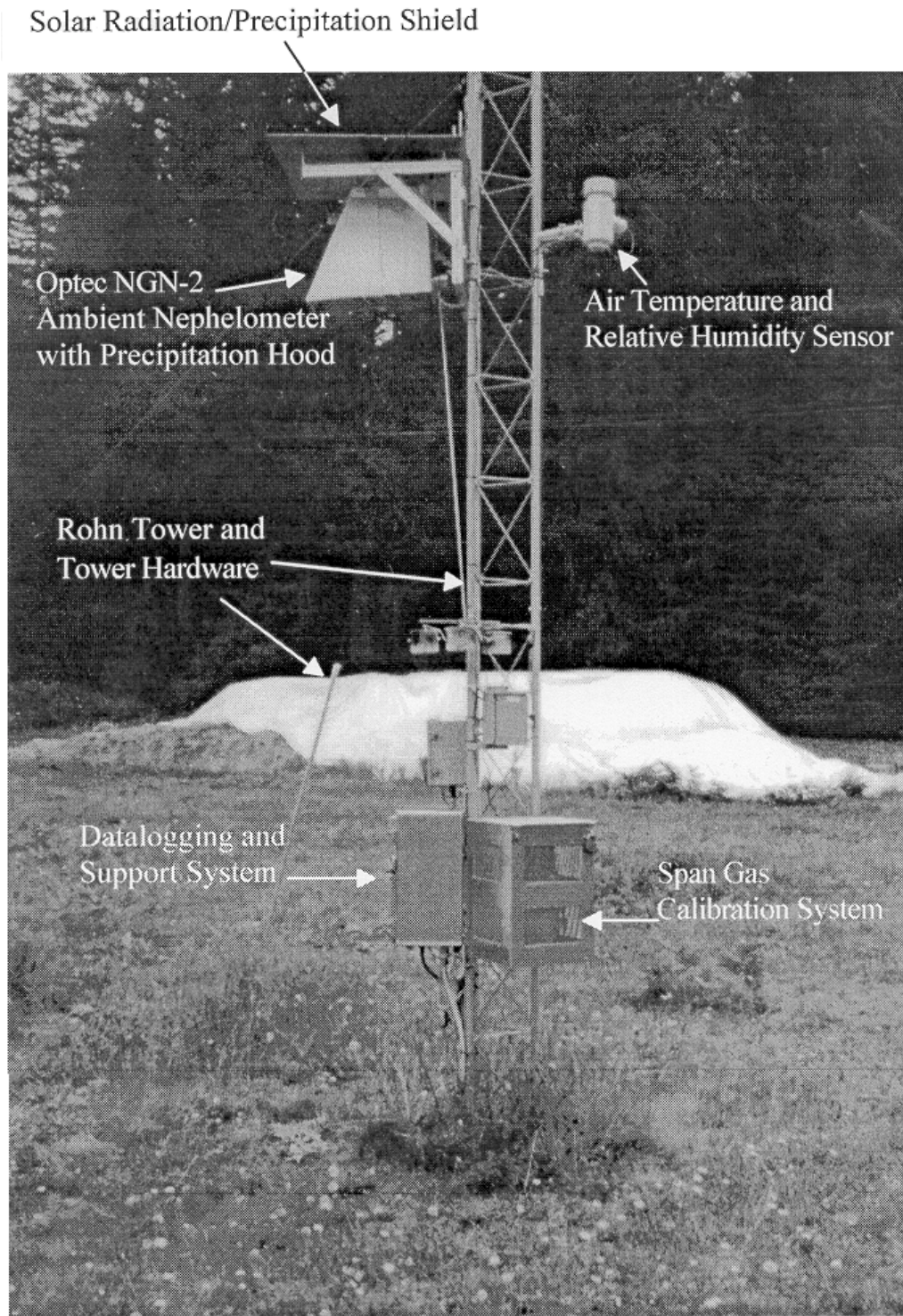

Figure 1-1. Typical Optec NGN-2 Nephelometer Station.

- TI 4100-3375 *Replacing and Shipping Nephelometer System Components*
- TI 4115-3005 *Annual Site Visit Procedures for Optec NGN-2 Nephelometer Systems (IMPROVE Protocol)*
- SOP 4200 *Calibration of Optical Monitoring Systems (IMPROVE Protocol)*
- TI 4200-2000 *Calibration of Optec NGN-2 Nephelometers (IMPROVE Protocol)*

2.0 RESPONSIBILITIES

2.1 PROGRAM MANAGER

The program manager shall review site preparation, installation requirements, and the installation schedule with the project manager.

2.2 PROJECT MANAGER

The project manager shall:

- Review site preparation, installation requirements, and the installation schedule with the program manager and/or the project-specific Contracting Officer's Technical Representative (COTR) as required.
- Review final site preparation and installation plans with the field specialist.
- Schedule the installation.

2.3 FIELD SPECIALIST

The field specialist shall:

- Review final site preparation and installation plans with the project manager.
- Inform the local contact of the installation schedule.
- Review site preparation and installation requirements with the local contact, as required.
- Maintain communications with the local contact during site preparation. Verify that all required site preparation is completed prior to installation.
- Verify that all required clearances and permissions relating to the specific site, system installation, and regular servicing have been obtained prior to the installation.
- Schedule and arrange for any on-site assistance needed during the installation.
- Ship all required equipment to the site.
- Install the nephelometer station according to this TI.

- Train the site operator(s) according to TI 4115-3005, *Annual Site Visit Procedures for Optec NGN-2 Nephelometer Systems (IMPROVE Protocol)*.
- Calibrate the nephelometer system according to TI 4200-2000, *Calibration of Optec NGN-2 Nephelometers (IMPROVE Protocol)*.
- Complete all required site documentation according to TI 4070-3001, *Site Documentation for Optec NGN-2 Nephelometer Systems*.
- Provide completed site documentation to the data analyst.

2.4 DATA ANALYST

The data analyst shall:

- Verify transmission of data from the system upon completion of the installation.
- Enter all site documentation into the Quality Assurance Database.
- File all hardcopy site documentation provided by the field specialist.

2.5 LOCAL (ON-SITE) CONTACT

The local contact shall:

- Review site preparation and installation requirements with the field specialist.
- Identify and contact local landowners, land managers, primary contacts, and site operators regarding site installation and routine maintenance requirements.
- Perform or ensure completion of any site preparation required prior to the installation.
- Assist in obtaining any site-, installation-, and regular servicing-related clearances and permits.
- Provide on-site equipment and tools required during the installation.
- As required, provide assistance with the installation.
- Schedule the operator training session with pertinent routine servicing personnel and the field specialist.

3.0 REQUIRED EQUIPMENT AND MATERIALS

All system components listed in Section 1.0 of this TI are shipped to the site prior to installation. The following additional equipment and materials are also required:

- Complete set of installation tools
- Replacement connector kit

- Computer equipped with nephelometer/logger box communication capabilities
- Telephone line simulator
- Extra nephelometer lamps
- PVC pipe or flexible conduit
- All technical instructions (TIs) and standard operating procedures (SOPs) listed in Section 1.0
- Site Operator's Manual for Nephelometer Systems
- Nephelometer Installation Checklist
- Camera and color print film
- Pen or pencil

4.0 METHODS

Installation of Optec NGN-2 nephelometer stations is detailed in the following sixteen (16) subsections:

- 4.1 Site Preparation and Communication
- 4.2 Installing the Tower
- 4.3 Installing the Solar Radiation and Precipitation Shield
- 4.4 Installing the Precipitation Hood
- 4.5 Installing the Nephelometer
- 4.6 Installing the Datalogging and Control Subsystem
- 4.7 Installing the Rotronics AT/RH Sensor and Force-Aspirated Shield
- 4.8 Installing the Span Gas Calibration System
- 4.9 Connecting the AC Power
- 4.10 Connecting the Telephone Line
- 4.11 Completing the Operational Verification and Installation Checklist
- 4.12 Calibrating the Nephelometer
- 4.13 Site Documentation
- 4.14 Photographic Documentation
- 4.15 Operator Training
- 4.16 Completing Routine Site Maintenance

4.1 SITE PREPARATION AND COMMUNICATION

Prior to any installation visit:

- Review the determined site preparation and installation requirements with the local contact.
- Schedule all site preparation activities.

- Maintain communications with the local contact during site preparation. Verify that all required site preparation is completed prior to the installation.
- Document the primary site operator(s) and backup operator(s).
- Obtain permission from private and public landowners to access the monitoring location for installation training.
- Schedule the site installation visit and operator training session.
- Arrange for any necessary installation assistance, as well as tools and/or equipment (e.g., shovels, wheelbarrow, etc.).

Once on site:

- Inspect any site preparation that has been done.
- Verify that all shipped items have arrived in good condition.
- Verify the proposed installation configuration and scheduling for the operator training session with on-site personnel.

4.2 INSTALLING THE TOWER

Nephelometer system components are typically mounted on a 4 meter (14 foot) Rohn type-25 tower. Installation of the tower is described below and illustrated in Figure 4-1, Nephelometer Tower Components.

BASE PLATE

The tower base plate may be buried 6 to 12 inches or placed at ground level and staked with 2-foot construction stakes. The base plate must be oriented so that one face of the tower faces north.

TOWER ORIENTATION

The Rohn tower is triangular. The tower must be installed with one face oriented to true north. The nephelometer will be mounted on this northward face.

GUY WIRES

The tower is typically supported by three (3) guy wires. The type of guy wire anchors used depends on the type of ground at the site:

- Sand or loose soil - screw stakes or stakes with welded plate
- Rock - construction stakes driven into pre-drilled holes or rock anchors with eye-screws.

The guy wires attach to the top of the tower by looping over the extending tower posts and to ground stakes by connection to turnbuckles on the stakes. The guy wires must be adjusted so the tower does not move and is plumb in all directions.

The tower must be rigidly mounted before other system components are attached.

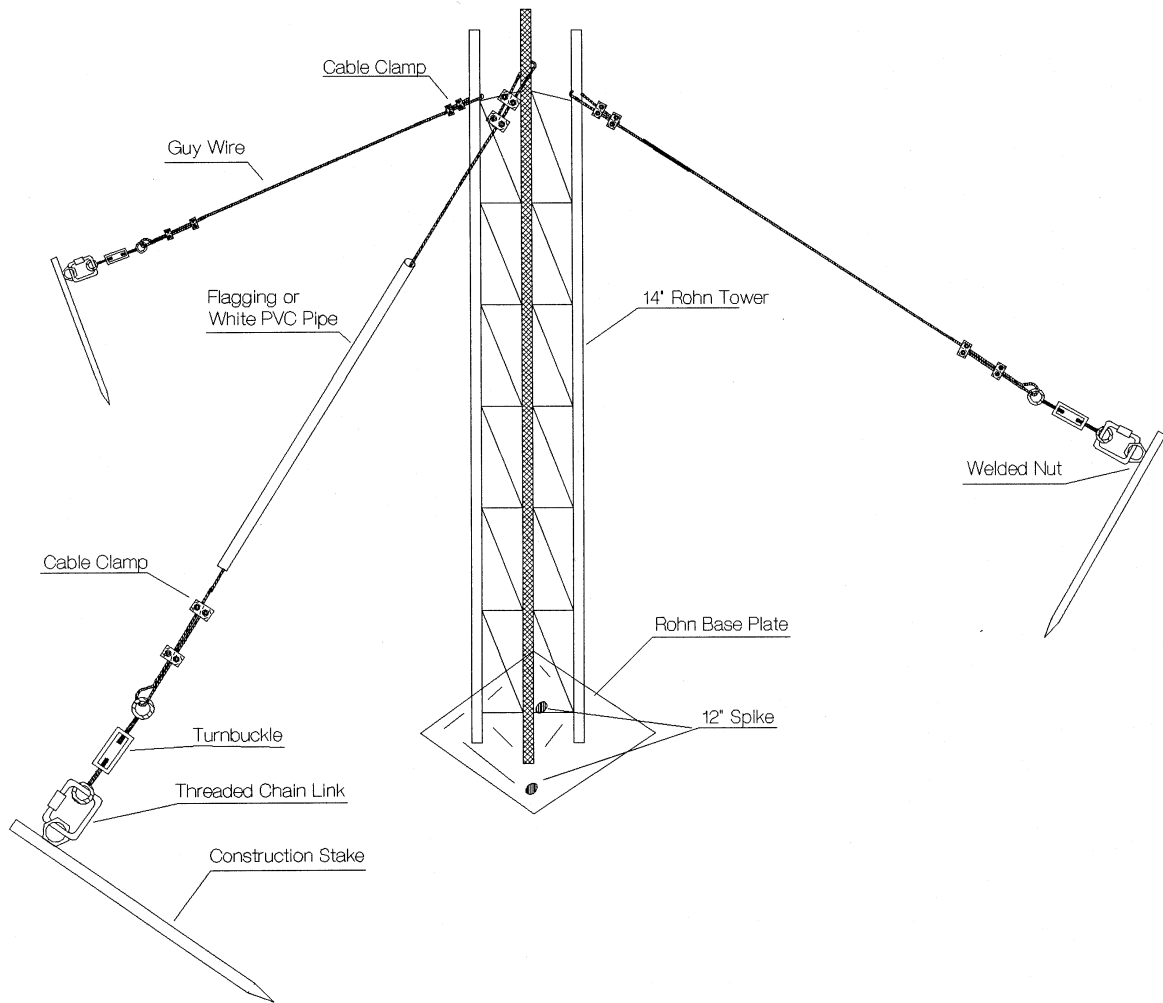

Figure 4-1. Nephelometer Tower Components.

4.3 INSTALLING THE SOLAR RADIATION AND PRECIPITATION SHIELD

The solar radiation and precipitation shield provides the following functions:

- Supports the nephelometer (the shield has mounting bolts and an integrated pulley system to accommodate easier installation and removal of the nephelometer)
- Protects the nephelometer from severe precipitation (rain, hail, etc.)
- Protects the nephelometer from direct solar radiation to maintain the instrument as close to ambient temperature as possible

The shield must be assembled before installation on the tower as described below and illustrated in Figure 4-2, Solar Radiation and Precipitation Shield Assembly.

ASSEMBLE THE FRAME AND ROOF Assemble the solar radiation and precipitation shield frame on the ground before attaching the frame to the tower. Note that the roof of the frame slants toward the back (tower side) of the frame to drain precipitation toward the rear of the shield. Do not attach the rear baffles to the frame at this time.

MOUNT FRAME TO TOWER Mount the frame to the north face of the tower and near the top so the roof just touches the guy wires. Use the supplied U-bolts to attach the frame to the tower.

ATTACH REAR BAFFLES TO FRAME Attach the rear baffles to the frame after mounting the frame to the tower. The baffles keep direct sun from heating the nephelometer, yet allow air flow to the instrument.

4.4 INSTALLING THE PRECIPITATION HOOD

The precipitation hood fits over the front (door side) of the nephelometer and is held in place by the nephelometer top mounting studs and the front feet. Installing the hood to the nephelometer is described below and illustrated in Figure 4-3, Precipitation Hood Installation Diagram.

REMOVE NEPHELOMETER Remove the nephelometer from the mounting bars of the existing precipitation/solar radiation shield and carefully lower the instrument to ground level using the rope and pulley system on the precipitation and solar radiation shield.

REMOVE FRONT FEET Remove the two front feet of the nephelometer by removing the flat head bolts under the feet. Set the feet and feet bolts aside, they will be reattached later.

MOUNT HOOD TO NEPHELOMETER Carefully slide the precipitation hood over the front of the nephelometer, making sure the top slits in the hood are aligned with the top mounting studs on the nephelometer. Slide the hood over the nephelometer until the backs of the slits of the hood meet the nephelometer mounting studs. Align the mounting holes on the bottom of the hood with the feet bolt holes. The hood is designed to fit tightly so some adjustment may be required.

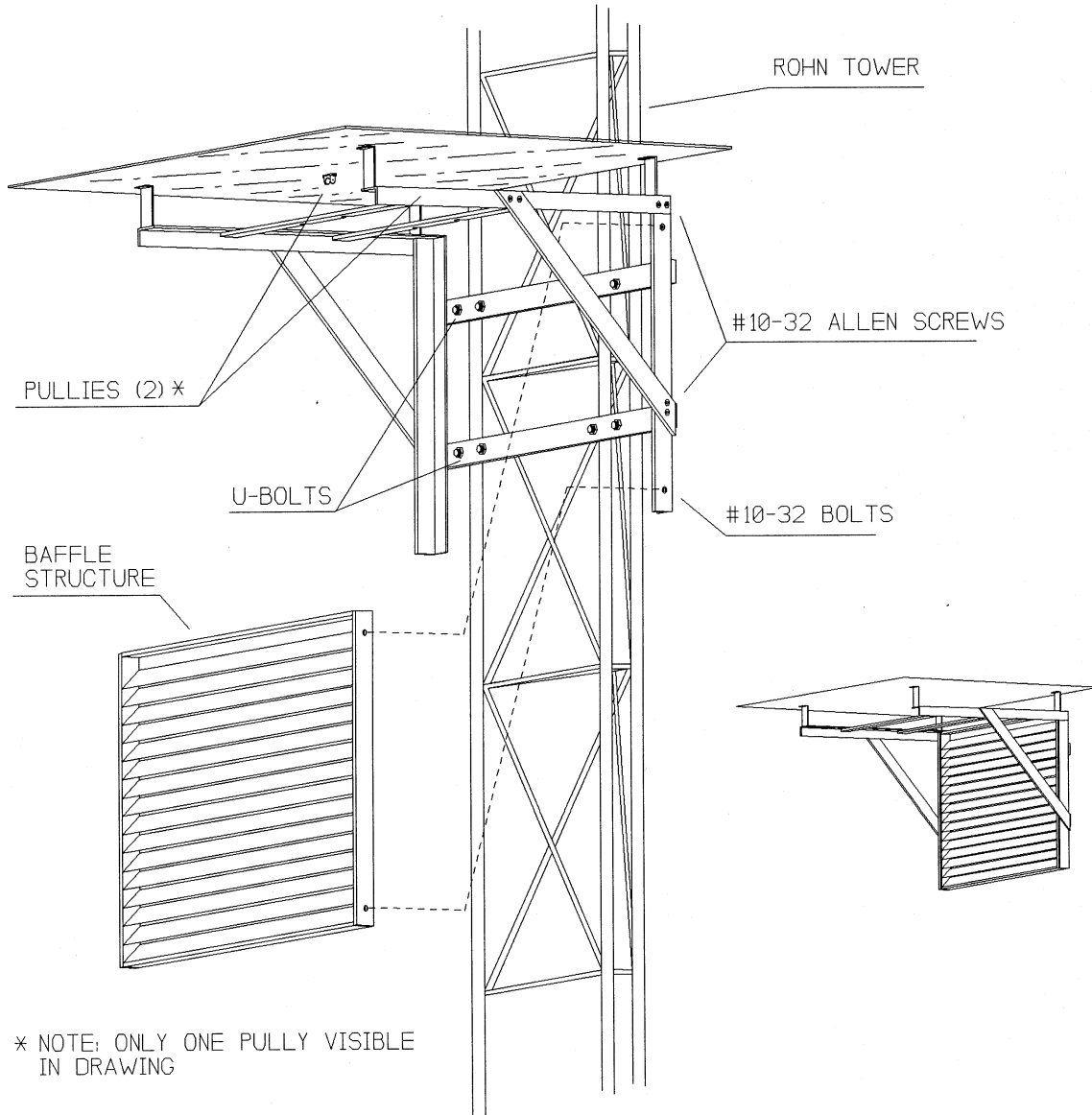

Figure 4-2. Solar Radiation and Precipitation Shield Assembly.

Precipitation Hood Installation Diagram

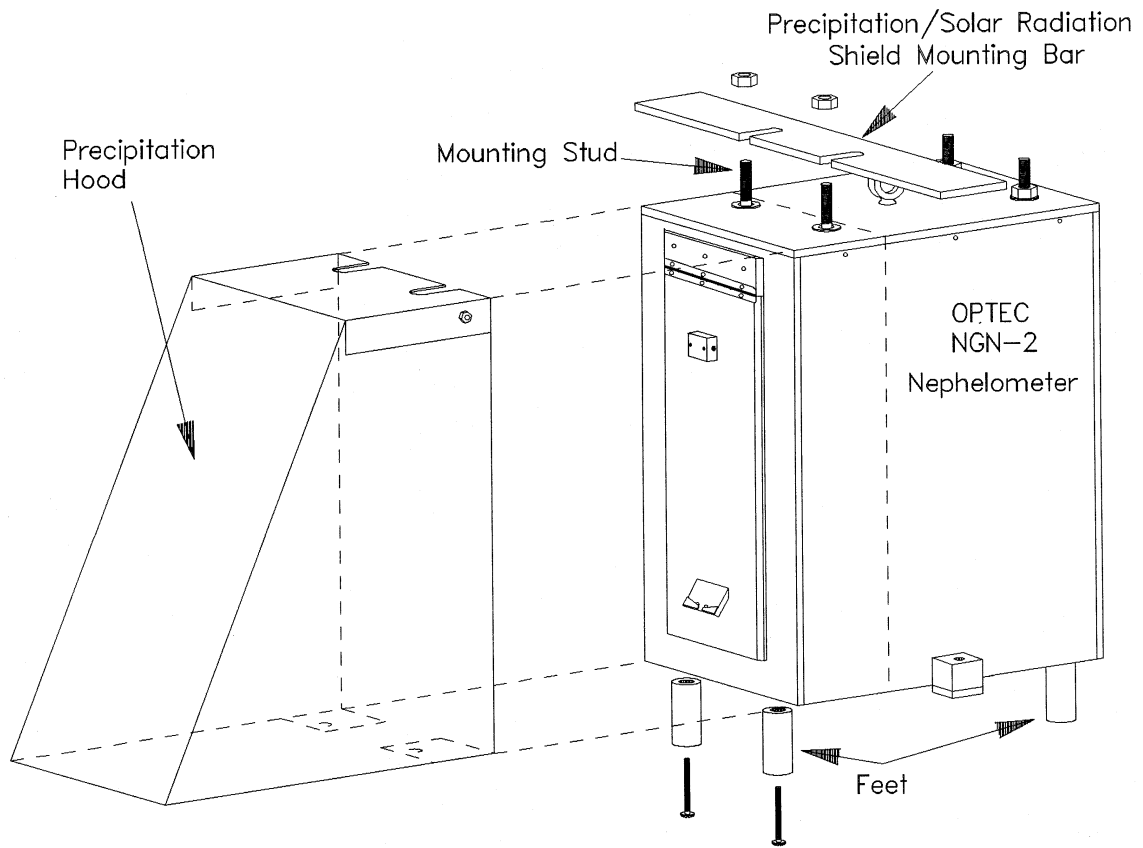

Figure 4-3. Precipitation Hood Installation Diagram.

ATTACH FRONT FEET

Reattach the two front feet to secure the bottom of the hood to the bottom of the nephelometer. The feet will temporarily hold the hood in place. Do not tighten the top mounting stud nuts.

4.5 INSTALLING THE NEPHELOMETER

Leave the nephelometer in the shipping case or box until at the site. Nephelometer installation procedures are detailed in TI 4100-3375, *Replacing and Shipping Nephelometer System Components*, and are summarized below:

UNPACK NEPHELOMETER EQUIPMENT

Carefully unpack the nephelometer and remove it from the shipping case or box.

ATTACH HOISTING ROPE

Feed the hoist rope through the two (2) pulleys on the underside of the precipitation and solar radiation shield (see Figures 4-2 and 4-3). Attach the nephelometer hoist rope attachment ring to the circular ring on top of the nephelometer (see Figure 4-4, Nephelometer Exterior Diagram).

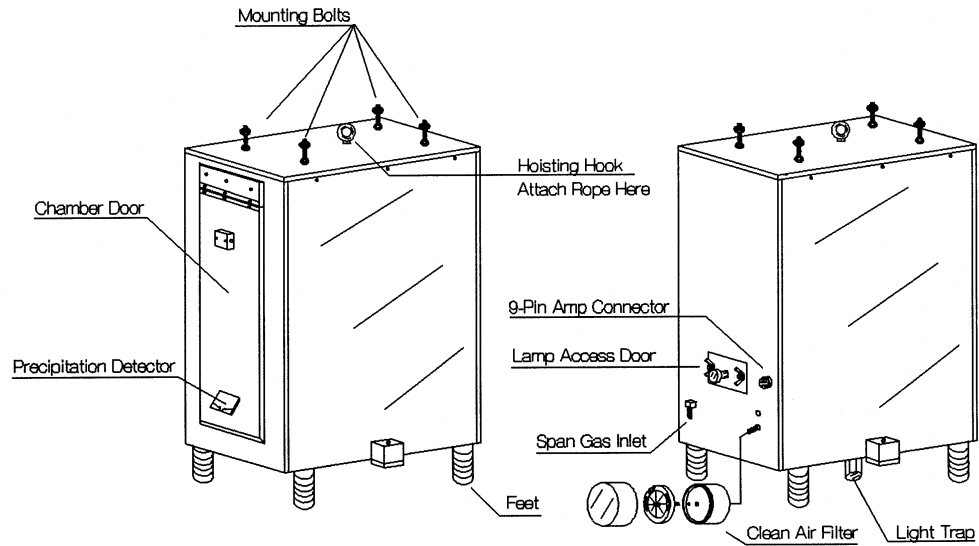

Figure 4-4. Nephelometer Exterior Diagram.

LOOSEN MOUNTING NUTS

Loosen but do not remove, the four (4) mounting nuts on the top of the nephelometer.

RAISE NEPHELOMETER

Use the rope and pulley system to raise the nephelometer to the precipitation and solar radiation shield.

SECURE ROPE TO TOWER

TIE THE ROPE SECURELY TO THE TOWER NEAR THE GROUND so that the nephelometer is suspended under the mounting bracket of the precipitation and solar radiation shield.

POSITION
NEPHELOMETER

Carefully slide the nephelometer top studs into the shield mounting slits, making sure that the top of the hood fits under the front shield mounting bar, and that the mounting nuts fit over the shield mounting bar. Verify that the hood is pushed fully against the nephelometer top studs. Tighten the two front stud mounting nuts down onto the shield mounting bar to secure both the nephelometer and hood. Tighten the rear stud mounting nuts.

4.6 INSTALLING THE DATALOGGING AND CONTROL SUBSYSTEM

Leave the datalogging and control subsystem in the shipping case or box until at the site. The support system is generally mounted on the north face of the tower above the highest expected snow level. Detailed installation procedures are provided in TI 4100-3375, *Replacing and Shipping Nephelometer System Components*, and are summarized below:

UNPACK
SYSTEM

Leave the datalogging and control subsystem in the shipping case or box until at the site.

Carefully unpack the system.

Open the enclosure and remove packing material from any internal components secured for shipping. The following items may require unpacking:

- Campbell datalogger
- Campbell storage module
- Campbell modem
- AC surge protector
- Other loose components

CHECK
COMPONENTS

Verify that all components in the enclosure are positioned properly (see Figure 4-5, Datalogging and Support Subsystem Component Diagram).

Check for loose wiring in the enclosure, especially on the datalogger terminal strips and interface circuit board.

ATTACH
ENCLOSURE
TO TOWER

Attach the enclosure to the tower mounting brackets using the four (4) bolts provided.

Attach the enclosure mounting brackets to the tower using the four (4) U-bolts provided.

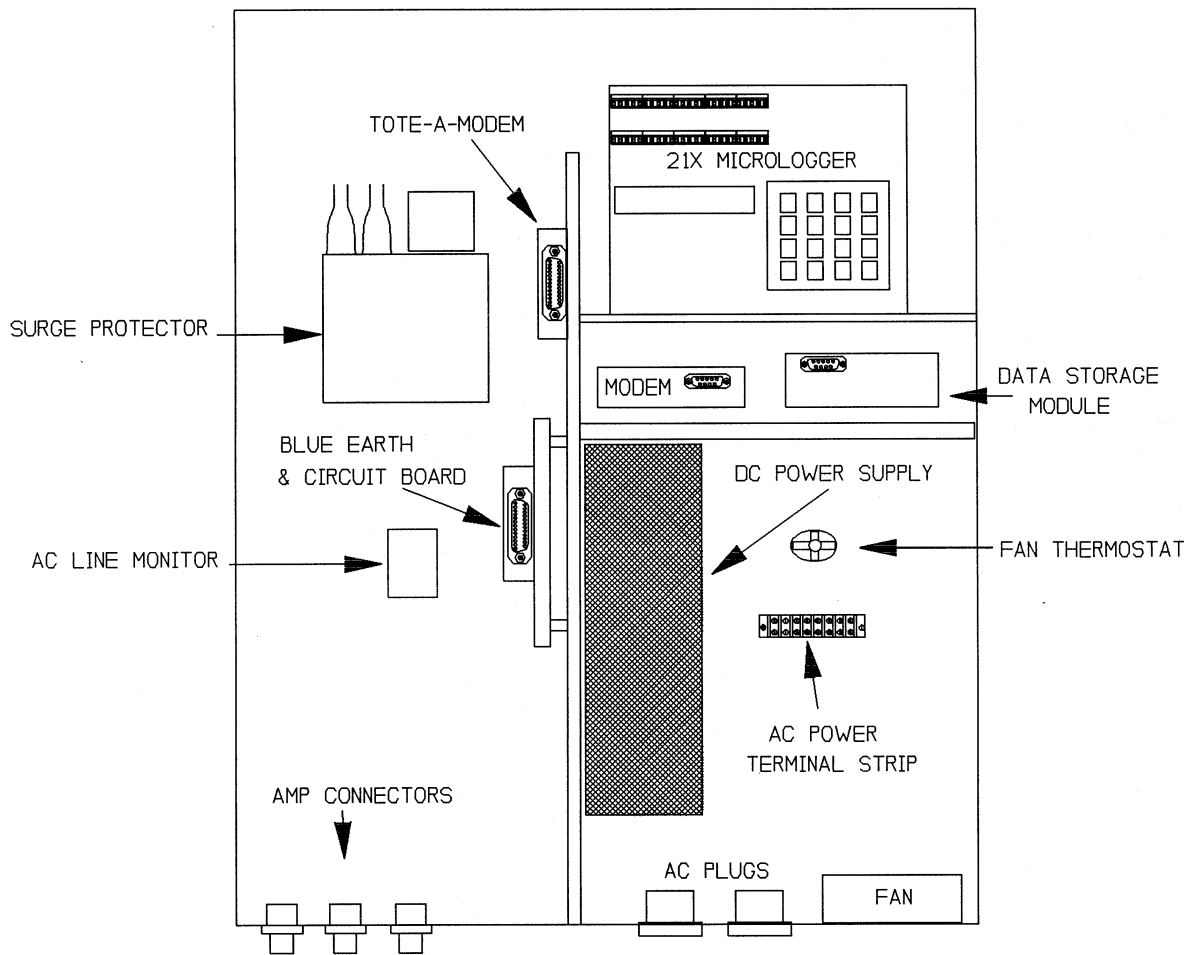

Figure 4-5. Datalogging and Support Subsystem Component Diagram.

**CONNECT
CABLES**

Connect the following cables to the connector panel on the bottom outside of the enclosure after inspecting each connector for dust and debris. Figure 4-6, Datalogging and Control Subsystem Connector Panel Diagram (Viewed From Inside the Enclosure), and Table 4-1, Datalogging and Control Subsystem Connector Panel Description, describe the connectors on the subsystem:

- AC power
- Nephelometer power/signal
- AT/RH sensor with fan power
- Telephone line
- Terminal

**TURN ON
POWER**

Turn on or plug in the main AC power supply to the enclosure.

**VERIFY
OPERATION**

Verify correct operation of the datalogging system (refer to TI 4100-3100, *Routine Site Operator Maintenance Procedures for Optec NGN-2 Nephelometer Systems (IMPROVE Protocol)*).

4.7 INSTALLING THE ROTRONICS AT/RH SENSOR AND FORCE-ASPIRATED SHIELD

The Rotronics AT/RH sensor in its force-aspirated shield is mounted to the tower with the air inlet at the bottom of the shield at the same level as the center of the nephelometer intake screen. The +12 VDC power for the aspiration fan and power and signal wires for the sensor come from the datalogging and control subsystem through a pair of attached cables. Figure 4-7 is an illustration of the sensor and shield. The following procedures describe the installation of the sensor and shield:

**ATTACH
SHIELD TO
TOWERt**

Attach the force-aspirated shield to the tower using the L-bracket and U-bolts. The air inlet at the bottom of the shield must be at the same level as the center of the nephelometer intake screen.

**ATTACH TO
POWER CABLE**

Attach the aspiration fan power connector to the power cable after inspecting for dust and debris within the two connectors. Clean the connectors if needed.

ATTACH SENSOR

Slide the sensor into the shield and tighten the securing screw.

Attach the sensor to the signal cable after inspecting for dust and debris within the two connectors. Clean the connector if needed.

**CHECK
SIGNAL
POWER**

Check that the signal power connector is connected to the datalogging and control subsystem. Refer to Figure 4-6 and Table 4-1 for datalogging and control subsystem connector information.

**VERIFY
OPERATION**

Verify sensor and aspiration fan operation.

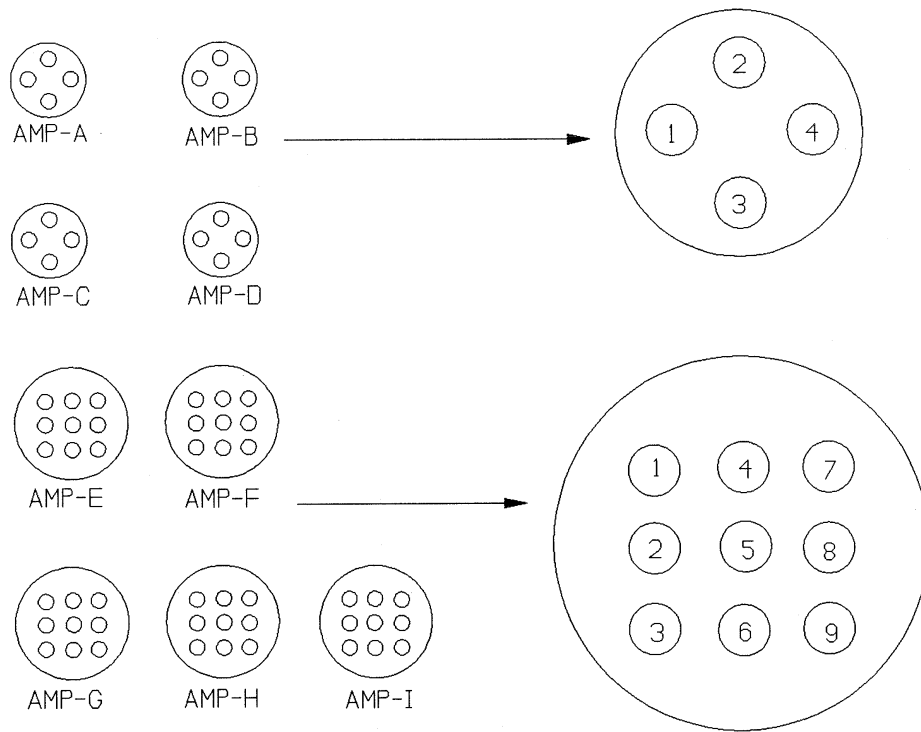

Figure 4-6. Datalogging and Control Subsystem Connector Panel Diagram (Viewed From Inside the Enclosure).

Table 4-1

Datalogging and Control Subsystem Connector Panel Description

Connector	Function
A	Terminal
B	Not used
C	Telephone line
D	Not used
E	Not used
F	Not used
G	Not used
H	Rotronics AT/RH and fan
I	Nephelometer

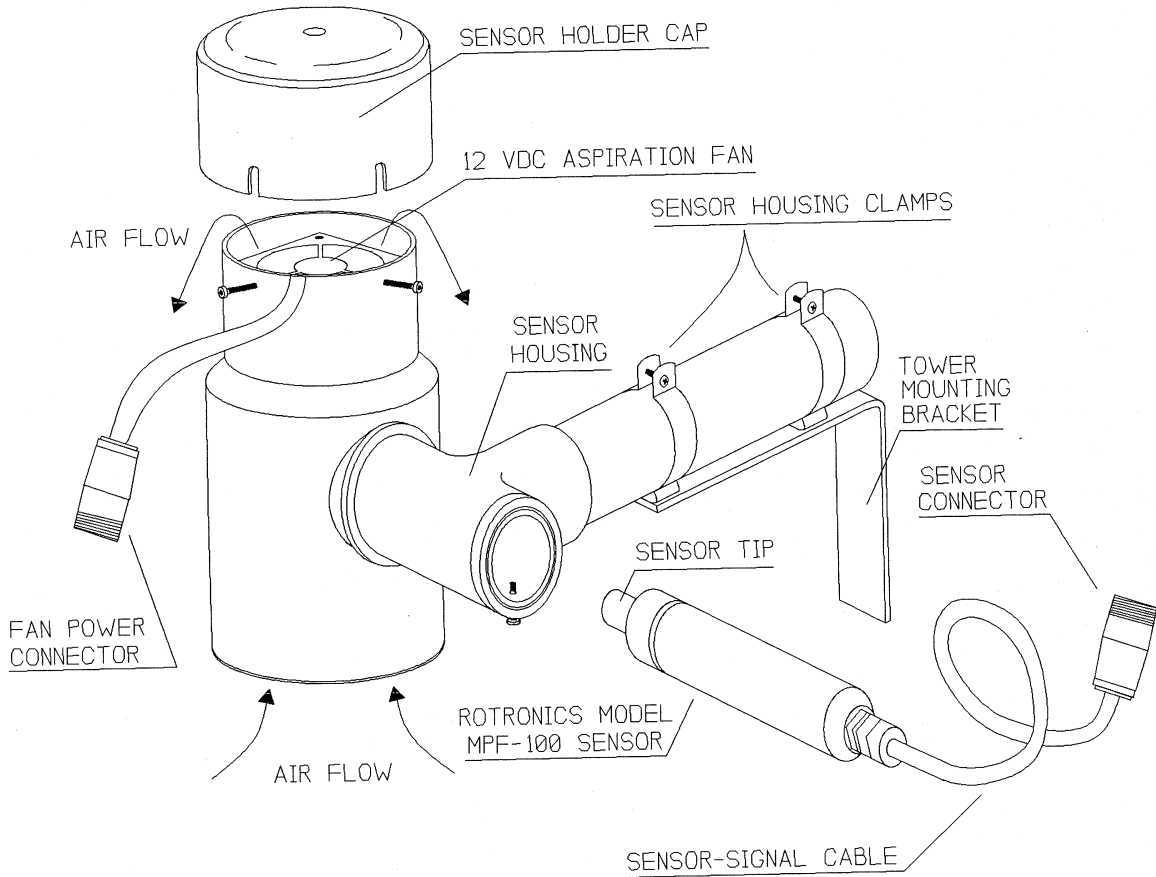

Figure 4-7. Rotronics AT/RH Sensor in Force-Aspirated Shield.

4.8 INSTALLING THE SPAN GAS CALIBRATION SYSTEM

The span gas calibration system is used by the site operator to perform scheduled span and zero calibration checks of the nephelometer. The system, illustrated in Figure 4-8, includes the following components:

- Span gas enclosure
- Span gas regulator
- Span gas rotameter with enclosure
- Span gas hoses
- Suva 134-A span gas tank

The span gas calibration system is typically attached to the tower as described below:

**ATTACH THE
SPAN GAS
ENCLOSURE**

Attach the span gas enclosure to the tower at the same level as the datalogging and control subsystem using the supplied mounting blocks and U-bolts.

**ATTACH THE
ROTAMETER
ENCLOSURE**

Attach the rotameter enclosure to the tower at a height of approximately five (5) feet (comfortable viewing level) using the supplied U-bolts (refer to Figure 4-8).

**ATTACH THE
SPAN GAS
HOSES**

Attach one end of the long span gas hose to the nephelometer span gas inlet. Attach the other end of the long span gas hose to the rotameter outlet fitting on the back of the rotameter enclosure. Attach one of the short span gas hoses from the rotameter inlet fitting to the outlet of the pressure regulator. Finally, connect the remaining short length of span gas hose from the outlet of the span gas tank to the inlet of the pressure regulator. Carefully tighten all connections slightly with pliers.

4.9 CONNECTING THE AC POWER

The nephelometer is generally AC powered. The method for running AC power from the AC source to the nephelometer station varies from site to site and depends on the following:

- Distance from the AC source to the station
- Termination (type of connection) of the AC at the source
- Local requirements (conduit, conductor type, etc.)
- Ground type (soil, rock, etc.)

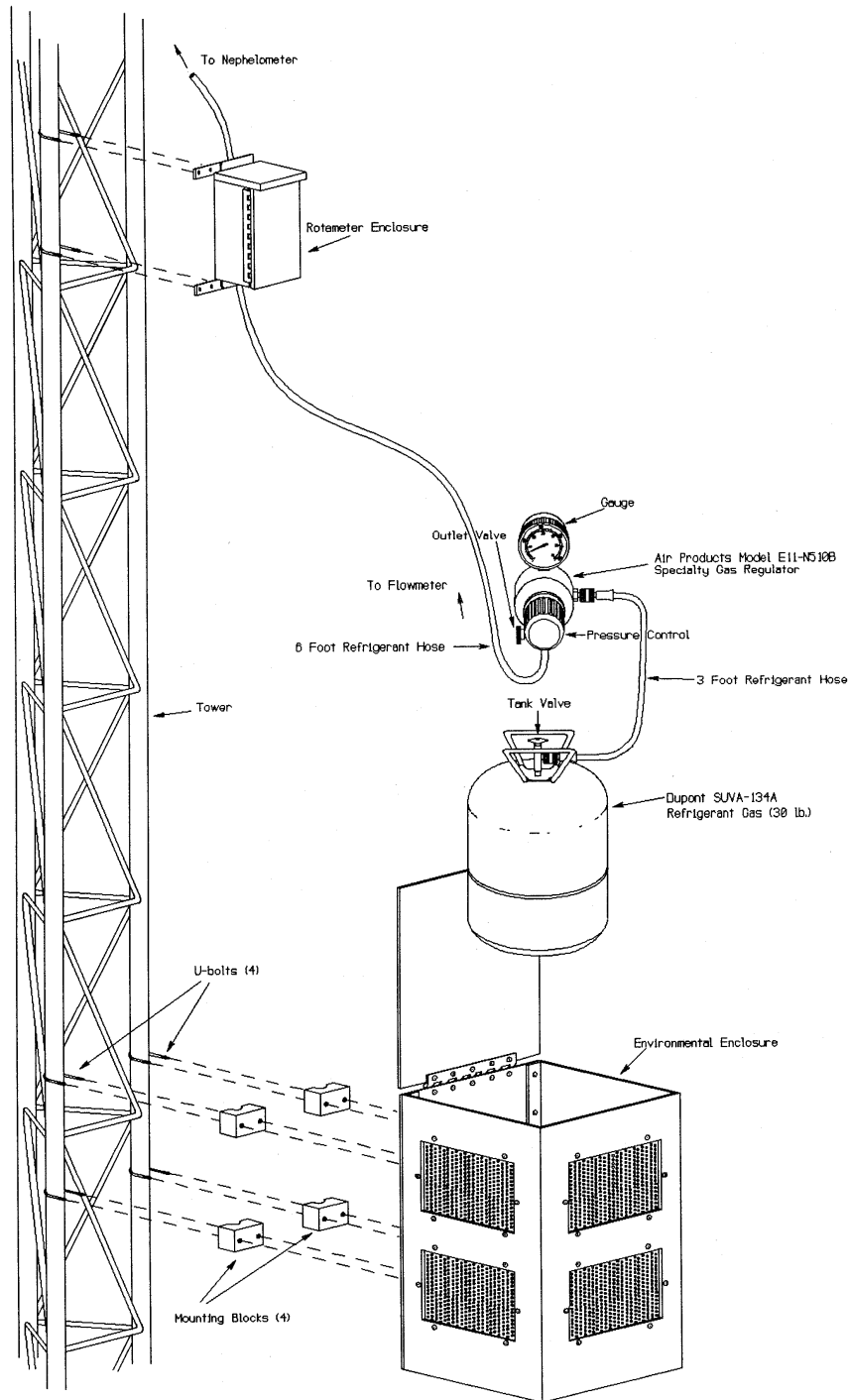

Figure 4-8. Span Gas Calibration System.

If the AC source is a standard wall outlet inside an aerosol IMPROVE shelter, the standard method for running the AC power line is as follows:

BURY PIPE Bury 1" diameter PVC pipe or flexible cable conduit from the shelter to the tower.

RUN AC LINE Run the AC line from an outlet in the shelter, through the pipe or conduit to the support system. Use a standard AC grounding plug inside the shelter and a female circular AR plug at the tower.

Other configurations may require assistance from a local electrician.

4.10 CONNECTING THE TELEPHONE LINE

Telephone communication with the nephelometer system through a standard telephone line is the preferred system configuration. If a standard telephone line is not available, cellular telephone options should be investigated. The following procedures describe a typical telephone installation assuming a standard line is available:

RUN PHONE LINE THROUGH PIPE The telephone line is generally terminated in a standard telephone company Network Interface Box. Run the phone line through a buried PVC pipe or flexible conduit from the Network Interface Box to the tower. Depending on the location of the Network Interface Box, the phone line can be run through the same PVC pipe or conduit as the AC power.

ATTACH PHONE LINE Attach the phone line to the red and green phone line termination screws in the Network Interface Box.

ATTACH AMP CONNECTOR Attach a 4-pin female circular AMP connector to the end of the line near the tower. The wiring for this connector is detailed in TI 4100-3350, *NGN-2 Nephelometer Monitoring System Diagrams and Component Descriptions*.

If cellular telephone service is required, the following procedures apply:

MOUNT POWER SUPPLY The cellular transceiver and power supply can be mounted in an enclosure on the tower or placed in a nearby shelter.

INSTALL ANTENNA A directional antenna (Yagi type or similar) is preferred over an omni-directional antenna. The antenna should be installed on the tower or shelter and aimed at the cellular site (the location of the cellular site is available from the cellular service provider).

4.11 COMPLETING THE OPERATIONAL VERIFICATION AND INSTALLATION CHECKLIST

Major functions of the nephelometer system can be verified by performing a routine site visit as is detailed in TI 4100-3100, *Routine Site Operator Maintenance Procedures for NGN-2 Nephelometer Systems (IMPROVE Protocol)*. Routine site visit procedures include a simple nephelometer calibration.

The NGN-2 Nephelometer Installation Checklist (Figure 4-9), enables documentation of installation checks performed. The checklist covers the following areas and is described below:

- Site access information
- Site documentation photographs
- Datalogger program version and storage module type
- Interface circuit board functionality
- AC power connection description
- Datalogging and control subsystem power indicators
- Telephone line connection description
- Nephelometer calibration
- Rotronics AT/RH sensor check

SITE ACCESS INFORMATION Document all locks (padlocks, gate locks, etc.) and other access requirements related to the site. Include lock type, manufacturer, ID number, and site personnel having responsibility for access.

PHOTOGRAPHS Verify that required site photographs were taken (see Section 4.14).

DATALOGGER PROGRAM Verify that the correct program is running in the datalogger and is stored in area #8 of the storage module. Record the datalogger program version and serial number of the storage module. Set the datalogger time to LOCAL STANDARD TIME.

INTERFACE CIRCUIT BOARD Verify operation of the interface circuit board, including:

- Check Blue Earth indicator LEDs:

<u>Color</u>	<u>Normal Status</u>	<u>Function</u>
Red	ON	Power OK when ON.
Yellow	OFF	Receiving serial data from the nephelometer when ON.
Green	OFF	Transmitting data to the nephelometer when ON.

NGN-2 NEPHELOMETER INSTALLATION CHECKLIST

Site Name _____ Site Abbreviation _____

Date _____ Local Time _____ () Service Personnel _____

Site Access Information

Document access requirements (locks and personnel) related to access to the site (type, manufacturer, ID number):

Photographs

Photograph the following:

Cardinal directions	YES	NO	
Surrounding area		YES	NO
General nephelometer shots	YES	NO	

Datalogger Program

21X program version: _____ Is program in storage module? _____

Storage module currently installed: _____

Time set to LOCAL STANDARD TIME on datalogger: YES NO

Interface Circuit Board

Blue Earth indicator LEDS? Red: ON OFF Yellow: ON OFF Green: ON OFF

Watchdog relay clicking? ON OFF

Toggle port #2 of the datalogger (*6A022) to reset the Blue Earth.

The Blue Earth should output a test sequence of:

1111 2222 3333 4444 5555 6666 7777 8888 9999 to the datalogger.

Examine datalogger locations 15-21 (*615AAA...).

Was the test sequence logged correctly? YES NO

Power Systems

Describe the AC power installation:

Are AC and DC indicator lamps operational? _____ Fuses OK? _____

Record output of DC power supply (VDC): _____

21X datalogger red LED on? YES NO

NGN-2 NEPHELOMETER INSTALLATION CHECKLIST (CONT.)

Telephone Line

Describe the telephone line installation:

Nephelometer

Verify Power On Self Test functions.

Verify correct serial and analog updates to 21X datalogger:

Correct output code: YES NO
Ambient value reasonable: YES NO
Lamp value adequate: YES NO

Document span gas system in use at site: _____

Nephelometer Calibration

	Zero Span	Zero Span	Zero Span	Zero Span	Zero Span	Zero Span	Zero Span	Zero Span	Zero Span
Simple Calibration									
Complete Calibration									

Rotronics AT/RH Sensor

Reference AT/RH sensor: Model _____ S/N _____ Last Calibration: _____

Use the reference sensor to check the operation of the on-site AT/RH sensor.

Record the following information from the reference sensor and 21X datalogger

*6 locations:

Reference AT: _____ On-Site AT (*6,1): _____
Reference RH: _____ On-Site RH (*6,2): _____

Figure 4-9. (Continued). Nephelometer Installation Checklist.

- Serial Test Sequence:

Toggle port #2 of the datalogger (*6 A 0 2 2) to interrupt power to the Blue Earth.

Examine datalogger locations 15-23 (*6 15 A A A ...). Verify that the following test sequence from the Blue Earth was logged correctly by the datalogger:

1111 2222 3333 4444 5555 6666 7777 8888 9999

POWER SYSTEMS

Note any relevant details regarding the AC power connection to the station. Verify correct operation of the power systems by checking the following:

- Line on indicator lamp on the UPS should be "ON"
- AC and DC indicator lamps should be "ON"
- Correct fuses: 2-amp AC fuse and 7-amp DC fuse
- Output of DC power supply should be 13.8 VDC nominal
- Red LED on side of datalogger should be "ON" to indicate that the datalogger charger is operating

TELEPHONE LINE

Note any relevant details regarding the telephone line connection. Verify correct operation of telephone access to the station by having ARS call the site.

NEPHELOMETER CALIBRATION

Record the results of several simple and complete calibrations in the table.

ROTRONICS AT/RH SENSOR

Verify correct operation of the Rotronics AT/RH sensor by comparing the output to a reference sensor.

- Record the model, serial number, and date of last calibration of the reference sensor.
- Record collocated sensor readings of AT and RH from the reference sensor and the on-site sensor.

4.12 CALIBRATING THE NEPHELOMETER

Calibrating the nephelometer is performed after all components have been installed and their correct operation verified. Several manual and automatic calibrations must be performed according to the following documentation:

- SOP 4200, *Calibration of Optical Monitoring Systems (IMPROVE Protocol)*
- TI 4200-2000, *Calibration of Optec NGN-2 Nephelometers (IMPROVE Protocol)*

Document all calibration results and provide the results to the data analyst.

4.13 SITE DOCUMENTATION

Site documentation for Optec NGN-2 nephelometer stations is described in TI 4070-3001, *Site Documentation for Optec NGN-2 Nephelometer Systems*. The site documentation form in TI 4070-3001 must be completed and provided to the data analyst after initial installation of a nephelometer system.

4.14 PHOTOGRAPHIC DOCUMENTATION

Photographic documentation is detailed in TI 4070-3001. Photographs provide an important record of the installation, especially for personnel unfamiliar with the site. The following list summarizes the required photographs:

- Cardinal directions from the tower (North, East, South, West)
- Detailed installation close-ups of telephone and AC wiring
- Photographs of any local sources or obstructions to air flow to the station
- Landmarks necessary to locate the site
- Photographs of the station from several viewpoints and directions
- Other detailed close-ups

4.15 OPERATOR TRAINING

Training the site operator is detailed in TI 4115-3005, *Annual Site Visit Procedures for Optec NGN-2 Nephelometer Systems (IMPROVE Protocol)*. Simultaneous training of primary and backup operators, as well as supervisors involved in the program is preferred. Training typically includes the following:

- Overview of the IMPROVE Program
- Overview of visibility (extinction, scattering, transmissometers, nephelometers, particle samplers, cameras)
- Nephelometer functional description and simplified theory of operation
- Nephelometer calibration (purpose and frequency)
- Nephelometer station component functional overview
- Detailed description of datalogger access
- Basic troubleshooting techniques
- Completion of the NGN-2 Nephelometer/Meteorology Log Sheet
- Operator questions

4.16 COMPLETING ROUTINE SITE OPERATOR MAINTENANCE

Routine site operator maintenance is performed by the field specialist as the last step of the installation visit. The procedures are detailed in TI 4100-3100, *Routine Site Operator Maintenance Procedures for Optec NGN-2 Nephelometer Systems (IMPROVE Protocol)*. Provide completed log sheets and other documentation to the data analyst.

QUALITY ASSURANCE/QUALITY CONTROL DOCUMENTATION SERIES	
TITLE	SITE DOCUMENTATION FOR OPTEC NGN-2 NEPHELOMETER SYSTEMS
TYPE	TECHNICAL INSTRUCTION
NUMBER	4070-3001
DATE	AUGUST 1993

AUTHORIZATIONS		
TITLE	NAME	SIGNATURE
ORIGINATOR	D. Scott Cismoski	
PROJECT MANAGER	James H. Wagner	
PROGRAM MANAGER	David L. Dietrich	
QA MANAGER	Gloria S. Mercer	
OTHER		

REVISION HISTORY			
REVISION NO.	CHANGE DESCRIPTION	DATE	AUTHORIZATIONS
0.1	Added data analyst respon's/minor changes	July 1996	

TABLE OF CONTENTS

<u>Section</u>	<u>Page</u>
1.0 PURPOSE AND APPLICABILITY	1
2.0 RESPONSIBILITIES	1
2.1 Project Manager	1
2.2 Field Specialist	1
2.3 Data Analyst	1
3.0 REQUIRED EQUIPMENT AND MATERIALS	1
4.0 METHODS	2
4.1 Location	2
4.2 Geographic Reference	3
4.3 Equipment Documentation	5
4.4 Meteorology and Climatology	6
4.5 General Comments and Additional Information	6
4.6 On-Site Equipment Inventory	6

LIST OF FIGURES

<u>Figure</u>	<u>Page</u>
4-1 NGN-2 Nephelometer Site Documentation Form	7

1.0 PURPOSE AND APPLICABILITY

This technical instruction (TI) describes site documentation for Optec NGN-2 nephelometer sites operated according to IMPROVE Protocol. The purpose of this TI is to assure quality data capture and minimize data loss by:

- Performing thorough on-site specification measurements.
- Documenting site specification measurements and other site-related information.

These site documentation procedures shall be completed upon any of the following:

- Installation or removal of the nephelometer station
- Change in location of the station
- Significant change(s) to the information included on the form

This TI is referenced from Standard Operating Procedure (SOP) 4070, *Installation and Site Documentation for Optical Monitoring Equipment*.

2.0 RESPONSIBILITIES

2.1 PROJECT MANAGER

The project manager shall review the completed NGN-2 Nephelometer Site Documentation Form(s) for completeness and accuracy.

2.2 FIELD SPECIALIST

The field specialist shall:

- Complete the NGN-2 Nephelometer Site Documentation Form upon installation, removal, or movement of the nephelometer station.
- Provide completed site documentation to the data analyst.

2.3 DATA ANALYST

The data analyst shall:

- Enter all site documentation into the Quality Assurance Database.
- File all hard copy site documentation provided by the field specialist.

3.0 REQUIRED EQUIPMENT AND MATERIALS

The following equipment and materials are required for nephelometer site documentation:

- NGN-2 Nephelometer Site Documentation Form

- Pen or pencil
- Camera loaded with color print film
- Topographic maps of the area

4.0 METHODS

Site documentation of NGN-2 nephelometer stations includes completion of the NGN-2 Nephelometer Site Documentation Form. Information required regarding site documentation is detailed in the following subsections:

- 4.1 Location
- 4.2 Geographic Reference
- 4.3 Equipment Documentation
- 4.4 Meteorology and Climatology
- 4.5 General Comments and Additional Information
- 4.6 On-site Equipment Inventory

Figure 4-1 (presented at the end of this section) is an example NGN-2 Nephelometer Site Documentation Form.

4.1 LOCATION

Completion of Section I: Location, of the NGN-2 Nephelometer Site Documentation Form is detailed below.

SITE NAME, DATE, FORM COMPLETED BY	Record the full site name, including the type of site (e.g., national park, etc.), the date the form was completed, and the name of the person completing the form.
SITE ABBREV- IATION AND VERIFICATION	Record the four (4) character site abbreviation and the name of the person verifying the contents of the form.
SITE MAILING ADDRESS AND SHIPPING ADDRESS	Record the site mailing address, the address to which correspondence is sent via US Mail. Record the shipping address, the address to which UPS can deliver parcels. The shipping address cannot be a post office box.
NETWORK	Record the network name (e.g., IMPROVE).
SITE CONTACTS AND OPERATOR	Record the name, telephone, and fax numbers for any site operator(s), contact(s), and supervisor(s).
DATA RETRIEVAL PHONE NUMBER	Record the telephone number used to access the nephelometer station data collection modem if the station is so equipped.
INSTALLATION DATE	Record the date and time the nephelometer station was installed.

INSTALLED BY Record the name of the person(s) who installed the station.

BEGINNING DATE Record the date and time the nephelometer became operational.

4.2 GEOGRAPHIC REFERENCE

Completion of Section II: Geographic Reference, of the NGN-2 Nephelometer Site Documentation Form is detailed below.

GENERAL SITE DESCRIPTION Record any information that describes the general condition and layout of the site.

ELEVATION AND RAYLEIGH COEFFICIENT Record the elevation at ground level in meters of the station using the best available source (map, altimeter, etc.). Record the method used to determine the elevation. Record the Rayleigh coefficient for the station elevation.

INLET AND SENSOR HEIGHTS Record the nephelometer inlet and AT/RH sensor inlet heights above ground level in meters.

COORDINATES Record the coordinates (latitude and longitude) of the station in the following ways:

- Degrees, minutes, and seconds
- Decimal degrees
- UTM zone, easting, and northing

MAP REFERENCES Record references from any maps available and/or used to complete this form. Note the map name, scale, and source of the map.

MAP SKETCH Sketch a map to document the environment within 1/2 km radius of the site. Indicate trees, buildings, bodies of water, roads, parking areas, etc.

DOMINATING INFLUENCES Document any dominating point, area, and mobile pollutant influence on the site. List the source and pollutant.

LAND USE BY TYPE Document the type of land use within 1/2 km of the site by distance and direction. The following land use types are included:

- Urban Land Use:
 - Residential
 - Commercial
 - Industrial

- Mobile
- Other (describe)
- Non-Urban Land Use:
 - Agricultural
 - Forest
 - Desert
 - Residential
 - Mobile
 - Other (describe)

**LAND USE
BY DIRECTION**

Document the type of land use within 2-3 km of the site by direction. The land use types are listed above.

PHOTOGRAPHS

Attach separate photographs (3" x 5" color prints preferred) of:

- Site installation from various angles that document all site components.
- Cardinal direction views from the installation (N,E,S,W).

TOPOGRAPHY

Document the general characteristics of the terrain (smooth, rolling, or mountainous) over a 3 km radius from the site.

Document the type, size, direction, and distance from the site of the topographic features that influence the site, including:

- Hills
- Valleys
- Depressions
- Bodies of water
- Ridges
- Cliffs
- Other (describe)

OBSTRUCTIONS

List the type, size, direction, and distance from the site of any obstructions that could influence the site, including any of the following:

- Buildings
- Trees
- Ridges
- Cliffs
- Other (describe)

4.3 EQUIPMENT DOCUMENTATION

Completion of Section III: Equipment Documentation, of the NGN-2 Nephelometer Site Documentation Form is detailed below.

NETWORK	Record the network name, (e.g., IMPROVE).
SAMPLE FREQUENCY	Document the sampling frequency of the nephelometer and AT/RH sensors (e.g., usually 5 minutes for IMPROVE Protocol sites).
SITE CONFIGURATION	Describe the site configuration, including instrumentation.
POWER	Document the availability and location of AC and DC power.
DATALOGGER TYPE	Document the following: <ul style="list-style-type: none">• Type of primary datalogger• Type of telephone modem and telephone number• Type of DCP• DCP transmission information, including ID, channel, frequency, and transmit time• Other (specify)
COLLOCATED EQUIPMENT	Describe any collocated air quality and/or meteorological monitoring equipment, including: <ul style="list-style-type: none">• Type• Description• Parameters measured• Distance from nephelometer station• Sample height in meters above ground level

LOCAL UTILITIES Record the address, telephone number, and any contacts for the local telephone and electric utilities.

4.4 METEOROLOGY AND CLIMATOLOGY

Completion of Section IV: Meteorology/Climatology, of the NGN-2 Nephelometer Site Documentation Form is detailed below.

CLIMATE Document minimum, maximum, and average temperature and precipitation for the following periods:

- Annual
- Winter
- Spring
- Summer
- Fall

BAROMETRIC PRESSURE Document the name, code, elevation, and any comments for the three (3) nearest reporting weather stations that collect barometric pressure.

4.5 GENERAL COMMENTS AND ADDITIONAL INFORMATION

Completion of Section V: General Comments, Notes, or Additional Information, of the NGN-2 Nephelometer Site Documentation Form may include any or all of the following:

- Maps
- Drawings
- Statistics
- Other (describe)

4.6 ON-SITE EQUIPMENT INVENTORY

Completion of Section VI: On-site Equipment Inventory, of the NGN-2 Nephelometer Site Documentation Form, will ensure that all equipment is properly accounted for. All on-site equipment should be itemized in Section VI. Identify and list each component, including the manufacturer's name, stock number, model number, serial number, property number, and any other information necessary to properly inventory the equipment. The information provided in Section VI will serve as the primary reference for data entry into the project-specific inventory database. If detailed packing lists, inventory database printouts, or other information exist that fully describe the on-site equipment, verify this information and attach to Section VI.

Air Resource Specialists, Inc. NGN-2 NEPHELOMETER SITE DOCUMENTATION FORM			
I. LOCATION	Date:		
1. Site Name:	Form Completed by:		
2. Site Abbreviation:	Verified by:		
3. Site Mailing Address:	Site Shipping Address: (if different):		
4. Network:			
5. Site Contacts:	Name	Telephone	Fax
Site Operator:			
Supervisor:			
6. Data Retrieval Phone No.			
7. Installation Date:			
8. Installed By:			
9. Beginning Date of Operational Data Collection: Date: Time:			
II. GEOGRAPHIC REFERENCE			
1. General Site Description:			
2. Elevation at Ground Level	(m)	Rayleigh Coefficient:	(km ⁻¹)
3. Nephelometer Inlet Height (agl):	(m)	AT/RH Sensor Height (agl):	(m)
4. Coordinates D M S		Decimal Degrees	UTM
Longitude: : :			Zone:
Latitude: : :			East:
			North:
5. Map References:			

Figure 4-1. NGN-2 Nephelometer Site Documentation Form.

6.	Sketch a Map to Document the Environment Within a 1/2 km Radius of the Site (trees, buildings, bodies of water, roads, parking areas, etc.)																										
7.	<p>Dominating Influence of Site (indicate pollutant)</p> <p>Point:</p> <hr/> <p>Area:</p> <hr/> <p>Mobile:</p> <hr/>																										
8.	<p>Land Use Within 1/2 km Radius From the Site:</p> <table border="1" style="width: 100%; border-collapse: collapse;"> <thead> <tr> <th style="width: 30%; text-align: center;">Urban</th> <th style="text-align: center;">Distance and Direction From Site</th> </tr> </thead> <tbody> <tr> <td style="text-align: center;">Residential</td> <td></td> </tr> <tr> <td style="text-align: center;">Commercial</td> <td></td> </tr> <tr> <td style="text-align: center;">Industrial</td> <td></td> </tr> <tr> <td style="text-align: center;">Mobile</td> <td></td> </tr> <tr> <td style="text-align: center;">Other (describe)</td> <td></td> </tr> <tr> <td colspan="2" style="text-align: center;">Non-Urban</td> </tr> <tr> <td style="text-align: center;">Agricultural</td> <td></td> </tr> <tr> <td style="text-align: center;">Forest</td> <td></td> </tr> <tr> <td style="text-align: center;">Desert</td> <td></td> </tr> <tr> <td style="text-align: center;">Residential</td> <td></td> </tr> <tr> <td style="text-align: center;">Mobile</td> <td></td> </tr> <tr> <td style="text-align: center;">Other (describe)</td> <td></td> </tr> </tbody> </table>	Urban	Distance and Direction From Site	Residential		Commercial		Industrial		Mobile		Other (describe)		Non-Urban		Agricultural		Forest		Desert		Residential		Mobile		Other (describe)	
Urban	Distance and Direction From Site																										
Residential																											
Commercial																											
Industrial																											
Mobile																											
Other (describe)																											
Non-Urban																											
Agricultural																											
Forest																											
Desert																											
Residential																											
Mobile																											
Other (describe)																											
9.	<p>Predominant Land Use by Direction (2 to 3 km from the site; residential, commercial, industrial, suburban, urban, forest, etc.)</p> <p>N:</p> <hr/> <p>NE:</p> <hr/> <p>E:</p> <hr/> <p>SE:</p> <hr/> <p>S:</p> <hr/> <p>SW:</p> <hr/> <p>W:</p> <hr/> <p>NW:</p> <hr/>																										

Figure 4-1. (Continued). NGN-2 Nephelometer Site Documentation Form.

10.	Attach Separate Photographs of:			
	a. Site Installation			
	b. Cardinal Direction Photographs From Installation			(N,E,S,W)
11.	Topography			
	a. The General Characteristics of the Terrain Over a 3 km Radius From the Site are (check one): _____ Smooth _____ Rolling _____ Mountainous			
	b. Topographic Features That Influence the Site (Types: hills, valleys, depressions, bodies of water, ridges, cliffs, etc.):			
	Type	Size	Direction From Site	Distance From Site
12.	Obstructions			
	List Obstructions and Complete Information (Types: buildings, trees, ridges, cliffs, etc.):			
	Type	Size	Direction From Site	Distance From Site
III. EQUIPMENT DOCUMENTATION				
1.	Network:			
2.	Sample Frequency:			
3.	Site Configuration Description:			
4.	Power			
	a. AC Line Power:			
	b. DC Solar Power:			
5.	Datalogger Type:		Phone No.	
	a. Telephone/Campbell			
	b. Synergetics DCP/Campbell			
	c. Handar DCP/Campbell			
	d. Other			
	e. DCP Transmission Information			
	DCP Mfg.:	ID:	Channel:	Frequency:
				XTM Time:

Figure 4-1. (Continued). NGN-2 Nephelometer Site Documentation Form.

6. Collocated Air Quality and/or Meteorology Monitoring Equipment				
Type	Description/Parameters	Dist. From Neph (m)	Sample Height (agl)	
7. Local Telephone Company		8. Local Power Company		
Address:		Address:		
Telephone:		Telephone:		
IV. METEOROLOGY/CLIMATOLOGY				
1. Climate				
a. Temperature (C°)	Min.	Max.	Mean	
Annual				
Winter				
Spring				
Summer				
Fall				
b. Precipitation (mm)	Min.	Max.	Mean	Type
Annual				
Winter				
Spring				
Summer				
Fall				
2. Nearest Regularly Reporting Weather Stations With Barometric Pressure				
Name	Code	Elev.	Comments	
a.				
b.				
c.				

Figure 4-1. (Continued). NGN-2 Nephelometer Site Documentation Form.

V. GENERAL COMMENTS, NOTES, OR ADDITIONAL INFORMATION

A large, empty rectangular box with a thin black border, occupying most of the page. It is intended for handwritten or typed general comments, notes, or additional information related to the nephelometer site documentation.

Figure 4-1. (Continued). NGN-2 Nephelometer Site Documentation Form.

