



## TABLE OF CONTENTS

<b><u>Section</u></b>	<b><u>Page</u></b>
1.0 PURPOSE AND APPLICABILITY	1
2.0 RESPONSIBILITIES	2
2.1 Project Manager	2
2.2 Data Coordinator	3
2.3 Instrument Technician	3
2.4 Field Specialist	3
2.5 Site Operator	3
3.0 REQUIRED EQUIPMENT AND MATERIALS	4
3.1 Routine Maintenance	4
3.2 Annual Laboratory Maintenance	4
3.3 Inventory	4
4.0 METHODS	4
4.1 Monitoring System Diagrams and Component Descriptions	5
4.2 Routine Site Operator Maintenance	5
4.3 Replacing and Shipping Components	7
4.4 Annual Site Visits	7
4.5 Annual Laboratory Maintenance	7

## LIST OF FIGURES

<b><u>Figure</u></b>	<b><u>Page</u></b>
4-1 Typical Optec NGN-2 Nephelometer Station	6
4-2 Annual Service Procedure for Optec NGN-2 Nephelometers	9

## 1.0 PURPOSE AND APPLICABILITY

This standard operating procedure (SOP) outlines and describes the components of a comprehensive program for operating and maintaining the Optec NGN-2 nephelometer. The purpose of this program is to provide detailed operations and maintenance procedures that will assure quality data capture and minimize data loss.

The NGN-2 nephelometer (Next Generation Nephelometer) is manufactured by Optec, Inc. and was first installed in 1993. The instrument has evolved to its present configuration through a series of laboratory tests and operational field trials designed to meet the needs of the National Park Service (NPS) Visibility Monitoring and Data Analysis Program and the Interagency Monitoring of Protected Visual Environments (IMPROVE) Committee, and other visibility monitoring programs.

The NGN-2 meets the following criteria:

- Measures atmospheric scattering both day and night at 550 nanometers.
- Provides a direct, unobstructed path from outside air to the measurement chamber.
- Operates with minimal modification to the temperature, relative humidity, aerosols, and gases of the sampled ambient air.
- Allows easy servicing and component replacement with its modular design.
- Operates at low power for remote solar power installation.
- Provides automatic clean air and span gas calibrations at user-selected intervals.
- Operates with minimal required servicing.

The NGN-2 uses a unique integrating open-air design that allows accurate measurement of the scattering extinction coefficient of ambient air. Because of the open-air design, relative humidity and temperature of the air sample are essentially unchanged, thus the aerosol is negligibly modified when brought into the optical measuring chamber. Extinction due to scatter can accurately be measured from Rayleigh to 100% saturated fog conditions.

Integrating nephelometers estimate the atmospheric scattering coefficient by directly measuring the light scattered by aerosols and gases in a sampled air volume. Scattered radiation from an illumination source is integrated over a large range of scattering angles, in a defined band of visible wavelengths. Because the total light scattered out of a path is the same as the reduction of light along a path due to scattering, the integrating nephelometer gives a direct estimate of  $b_{\text{scat}}$ .

An environmentally-sealed compartment in the unit contains the single board computer, lamp assembly, motors, pumps, and electronics. The single board computer controls all operating functions of the NGN-2 which include: scattered light measurement, clean-air zero calibration, span gas calibration, moisture detection to close the optical chamber door during rain or snow conditions, optical chamber temperature measurement, initial data reduction, various error detection schemes, and diagnostic tests.

The Optec NGN-2 operations and maintenance quality assurance program consists of three (3) major categories:

- Routine Site Operator Maintenance
- Annual Site Visit
- Annual Maintenance

Detailed descriptions of the procedures to be followed in performing specific maintenance tasks referenced in this SOP are provided in the following SOPs and technical instructions (TIs):

- TI 4100-3100 *Routine Site Operator Maintenance Procedures for Optec NGN-2 Nephelometer Systems (IMPROVE Protocol)*
- TI 4100-3350 *NGN-2 Nephelometer Monitoring System Diagrams and Component Descriptions*
- TI 4100-3375 *Replacing and Shipping Nephelometer System Components*
- TI 4100-3400 *Nephelometer Annual Laboratory Maintenance (IMPROVE Protocol)*
- SOP 4115 *Annual Site Visits for Optical Monitoring Instrumentation (IMPROVE Protocol)*
- TI 4115-3005 *Annual Site Visit Procedures for Optec NGN-2 Nephelometer Systems (IMPROVE Protocol)*
- SOP 4700 *Optec NGN-2 Nephelometer Audit Procedures (IMPROVE Protocol)*

## **2.0 RESPONSIBILITIES**

### **2.1 PROJECT MANAGER**

The project manager shall:

- Oversee the activities of the data coordinator, instrument technician, and field specialist.
- Oversee and review site operator documentation.
- Oversee and review instrument maintenance records.
- Review routine maintenance and troubleshooting plans with the data coordinator, field specialist, and instrument technician as required.
- Review and approve any changes to maintenance procedures.

## **2.2 DATA COORDINATOR**

The data coordinator shall:

- Coordinate site operator activities and schedules.
- Review site operator documentation.
- Provide technical support to the site operator.
- Coordinate replacement of malfunctioning equipment.
- Ship cleaning and other necessary supplies to the site operator.
- Document all communications with the site operator.
- Enter the results of all performed procedures into site-specific timelines.

## **2.3 INSTRUMENT TECHNICIAN**

The instrument technician shall:

- Perform annual servicing of transmissometers and associated support equipment.
- Repair damaged or malfunctioning nephelometers and associated support equipment.
- Maintain an inventory of spare parts and servicing supplies.
- Document all servicing and maintenance work.

## **2.4 FIELD SPECIALIST**

The field specialist shall:

- Coordinate maintenance schedules with the project manager, data coordinator, and site operator.
- Provide technical support to the site operator.
- Perform field repair or replacement of nephelometer system components.
- Train the site operator in routine maintenance procedures.

## **2.5 SITE OPERATOR**

The site operator shall:

- Coordinate the schedule and requirements for specific nephelometer component replacement and shipment procedures.
- Perform routine nephelometer system service and maintenance tasks.

- Document all on-site service and maintenance work performed.
- Report any problems immediately.
- Participate in site operator training sessions.

### **3.0 REQUIRED EQUIPMENT AND MATERIALS**

ARS will maintain a sufficient inventory of spare components and repair parts to accommodate routine maintenance of the Optec NGN-2 nephelometer and associated support equipment. Required equipment and materials vary depending upon the servicing task, as detailed in the following subsections.

#### **3.1 ROUTINE MAINTENANCE**

Routine maintenance requires a small set of standard mechanical tools (screwdrivers, wrenches, etc.), fuses, a nephelometer lamp and clean air filter cartridge, and documentation supplies. A detailed list of equipment and materials for routine maintenance is provided in TI 4100-3100, *Routine Site Operator Maintenance Procedures for Optec NGN-2 Nephelometer Systems (IMPROVE Protocol)*.

#### **3.2 ANNUAL LABORATORY MAINTENANCE**

Annual laboratory maintenance requires specific instrumentation, including a digital voltmeter, dual channel oscilloscope, regulated power supply, optical laboratory equipment, an IBM PC-compatible computer terminal and circuit board test fixture, cleaning supplies, a small set of standard mechanical tools, and servicing forms and instrument manuals. A detailed list of equipment and materials for annual laboratory maintenance is provided in TI 4100-3400, *Nephelometer Annual Laboratory Maintenance (IMPROVE Protocol)*.

#### **3.3 INVENTORY**

It is imperative that all capital instrumentation changes made as a result of routine and annual maintenance be thoroughly documented and maintained in the ARS Purchase Order/Inventory Database. Specific model and serial number items tracked are discussed further in the maintenance TIs.

#### **4.0 METHODS**

This section includes five (5) major subsections:

- 4.1 Monitoring System Diagrams and Component Descriptions
- 4.2 Routine Site Operator Maintenance
- 4.3 Replacing and Shipping Components
- 4.4 Annual Site Visits
- 4.5 Annual Laboratory Maintenance

Each nephelometer site is supplied with a *Site Operator's Manual for Nephelometer Systems*. This manual contains SOPs and TIs applicable to site operator maintenance and manufacturer's instruction manuals for the NGN-2 nephelometer and associated support equipment.

#### **4.1 MONITORING SYSTEM DIAGRAMS AND COMPONENT DESCRIPTIONS**

Instrumentation at a typical IMPROVE network nephelometer site is shown in Figure 4-1 and generally includes:

- An Optec NGN-2 nephelometer.
- A gas calibration system.
- A datalogging and control subsystem.
- A shielded and aspirated Rotronics air temperature and relative humidity sensor.
- A support tower and related hardware.
- A precipitation and solar radiation shield.

The NGN-2 nephelometer outputs a two-minute integrated average value for measured ambient scattering at five-minute intervals. The on-site datalogger collects nephelometer data, along with instantaneous measurements of air temperature and relative humidity at five minute intervals. At site with telephone lines, the on-site datalogger is interrogated daily via telephone modem. At sites where telephone access is unavailable, preliminary data from the on-site datalogger are transmitted via GOES satellite and Handar data collection platforms (DCPs). Final data are retrieved from solid-state data storage modules. Clean air calibrations occur every six hours and automatic span calibrations and automatic tests occur at power-up. Complete descriptions of all nephelometer system components are provided in TI 4100-3350, *NGN-2 Nephelometer Monitoring System Diagrams and Component Descriptions*.

#### **4.2 ROUTINE SITE OPERATOR MAINTENANCE**

Routine site operator maintenance for the NGN-2 nephelometer should be performed weekly and includes the following general tasks:

- Inspecting the condition of all structural hardware, nephelometer components, support system components, and meteorological sensors
- Verifying power system status
- Checking system timing
- Initiating a zero and upscale/span calibration check
- Observing the Power-On Self Test (POST)
- Exchanging the data storage module
- Documenting system readings.

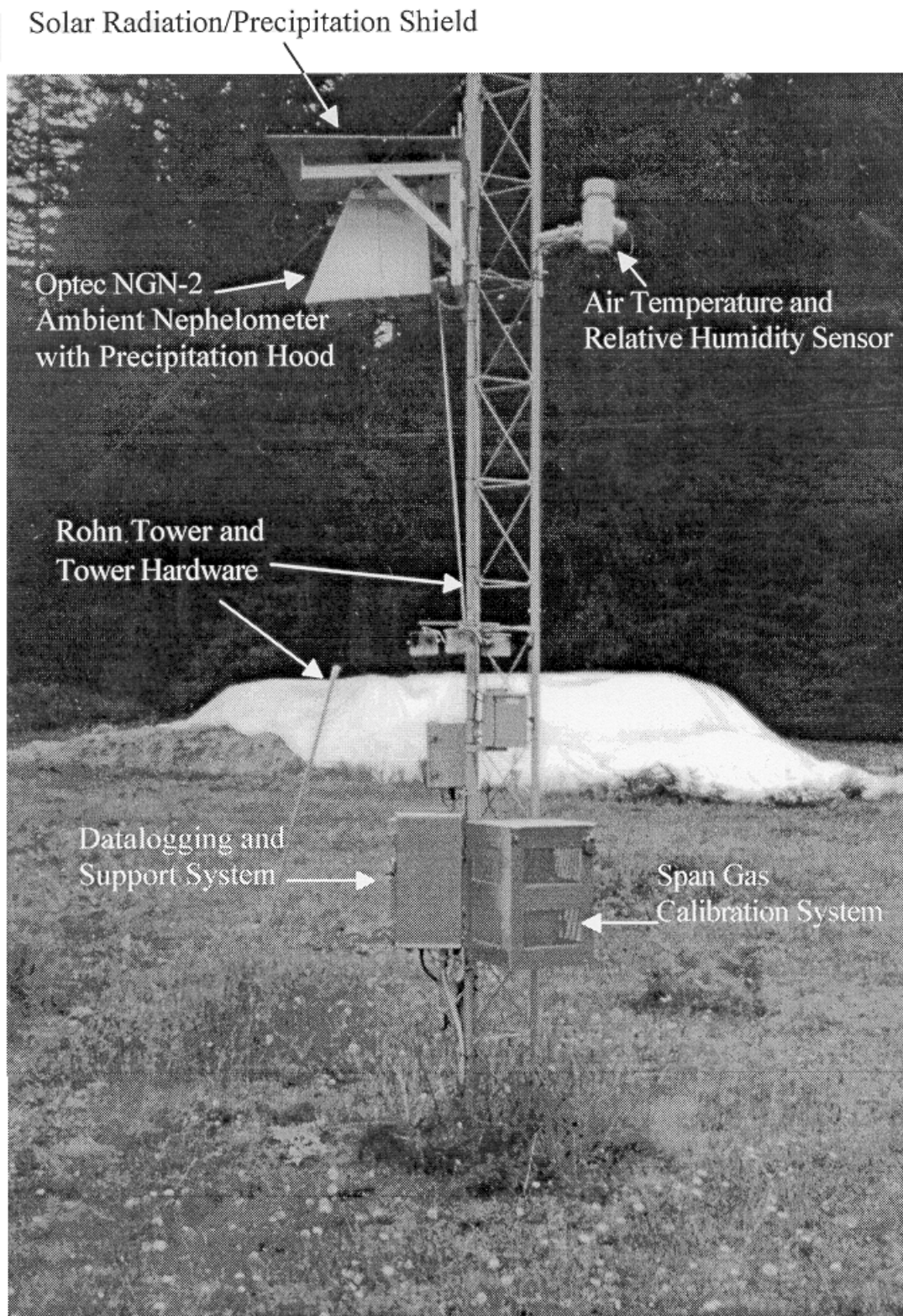

Figure 4-1. Typical Optec NGN-2 Nephelometer Station.



All observations and noted problems are documented on an NGN-2 Nephelometer/Meteorology Log Sheet. In most cases, site operators can diagnose and solve nephelometer system problems in the field. The majority of nephelometer problems are due to moisture in the nephelometer, lamp malfunction, electrical power outages or surges, and lightning induced voltage spikes. Detailed routine maintenance procedures are discussed in TI 4100-3100, *Routine Site Operator Maintenance Procedures for Optec NGN-2 Nephelometer Systems (IMPROVE Protocol)*.

### **4.3 REPLACING AND SHIPPING COMPONENTS**

Periodic maintenance for the NGN-2 nephelometer is required when a malfunctioning unit or system must be replaced. System components that may require removal include the nephelometer, the data collection platform, the datalogging and control subsystem, and the air temperature/relative humidity sensor. Each component must be properly removed and packaged for shipping to prevent further damage. Detailed discussions regarding replacing each component are presented in TI 4100-3375, *Replacing and Shipping Nephelometer System Components*.

### **4.4 ANNUAL SITE VISITS**

IMPROVE nephelometers operate in the field for a period of 12 months. An ARS field specialist annually visits each site and removes the "old" nephelometer and replaces it with a fully-serviced instrument. As a part of this annual site visit, the field specialist performs the following general tasks:

- Documents initial conditions.
- Verifies existing system operation and calibration (pre-removal).
- Replaces the nephelometer, datalogging and control subsystem, and AT/RH sensor.
- Verifies replacement system operation and calibration.
- Trains site operator(s).

In addition, nephelometers are typically audited at least once a year, but can be audited at anytime. The audits are performed by independent auditors.

SOP 4115, *Annual Site Visits for Optical Monitoring Instrumentation (IMPROVE Protocol)*, describes the annual site visit. Detailed procedures for the annual site visit are provided in TI 4115-3005, *Annual Site Visit Procedures for Optec NGN-2 Nephelometer Systems (IMPROVE Protocol)* and SOP 4700, *Optec NGN-2 Nephelometer Audit Procedures (IMPROVE Protocol)*.

### **4.5 ANNUAL LABORATORY MAINTENANCE**

The Optec NGN-2 nephelometer is a precision instrument that requires careful cleaning and inspection to ensure optimum measurement accuracy. This level of servicing must be performed in a laboratory environment using specialized electronic and optical test equipment. Nephelometers operating in the IMPROVE network are replaced in the field and serviced on an annual basis.

When the operational instrument is removed from the field, it is shipped back to ARS for servicing. Each instrument must be fully serviced before it is reinstalled at a field site. Servicing includes the following major tasks:

- Visual inspection
- Post-field calibration
- Cleaning
- Hardware upgrade/modifications
- Component functional tests
- Pre-field calibration

Specific tasks in the laboratory servicing procedure are shown in Figure 4-2, Annual Service Procedure for Optec NGN-2 Nephelometers. Each servicing task and procedure for performing the task is fully described in TI 4100-3400, *Nephelometer Annual Laboratory Maintenance (IMPROVE Protocol)*.

Instrument calibration is described in SOP 4200, *Calibration of Optical Monitoring Systems (IMPROVE Protocol)*. Calibration procedures are presented in TI 4200-2000, *Calibration of Optec NGN-2 Nephelometers (IMPROVE Protocol)*.

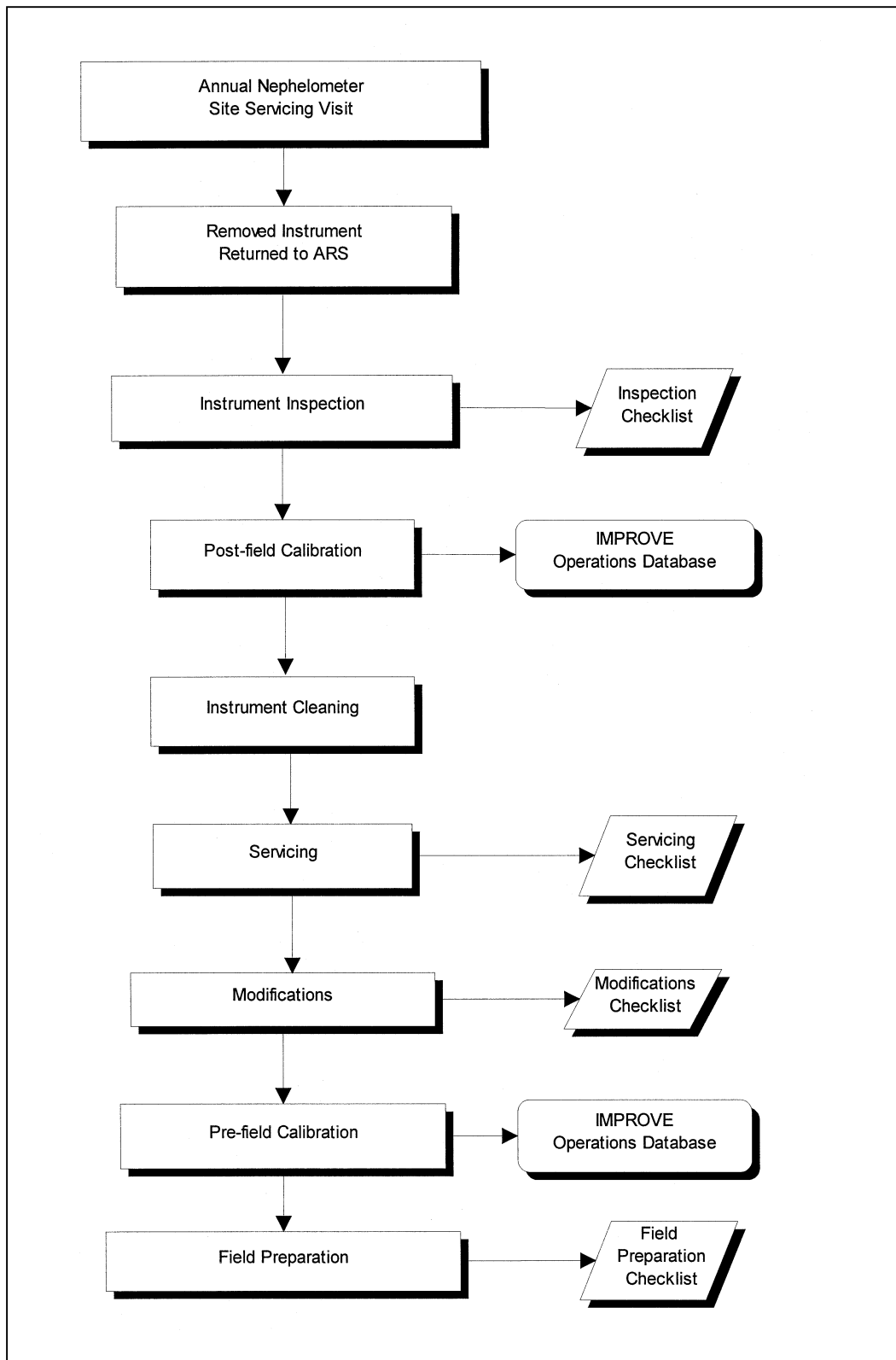

Figure 4-2. Annual Service Procedure for Optec NGN-2 Nephelometers.

QUALITY ASSURANCE/QUALITY CONTROL DOCUMENTATION SERIES

**TITLE**                    **ROUTINE SITE OPERATOR MAINTENANCE PROCEDURES FOR OPTEC  
NGN-2 NEPHELOMETER SYSTEMS (IMPROVE PROTOCOL)**

**TYPE**                    **TECHNICAL INSTRUCTION**

**NUMBER**                **4100-3100**

**DATE**                    **FEBRUARY 1993**

AUTHORIZATIONS

TITLE	NAME	SIGNATURE
ORIGINATOR	D. Scott Cismoski	
PROJECT MANAGER	James H. Wagner	
PROGRAM MANAGER	David L. Dietrich	
QA MANAGER	Gloria S. Mercer	
OTHER		

REVISION HISTORY

REVISION NO.	CHANGE DESCRIPTION	DATE	AUTHORIZATIONS
1.0	Zero/Span check procedural change	March 1994	
2.0	Revised upscale calibration procedures	April 1995	
2.1	Revised nephelometer/meteorology log sheet	July 1995	
3.0	Added troubleshooting procedures	October 1995	
4.0	Added responsibilities and format change	October 1996	

## TABLE OF CONTENTS

<b><u>Section</u></b>	<b><u>Page</u></b>
1.0 PURPOSE AND APPLICABILITY	1
2.0 RESPONSIBILITIES	4
2.1 Project Manager	4
2.2 Field Specialist	4
2.3 Data Coordinator	4
2.4 Site Operator	5
3.0 REQUIRED EQUIPMENT AND MATERIALS	5
4.0 METHODS	6
4.1 Routine Servicing	6
4.1.1 Support Tower, Guy Wires, and/or Other Structural Components	9
4.1.2 AC and DC Power Indicator Lamps	9
4.1.3 Datalogger	10
4.1.4 Nephelometer	15
4.1.5 Meteorology	20
4.1.6 Support System	20
4.1.7 General Comments and Supplies Needed	22
4.2 On-Site Troubleshooting	22
4.2.1 General Troubleshooting Information	22
4.2.2 Specific Troubleshooting Procedures	24
4.3 Problems or Questions	27
4.4 Handling Log Sheets	27

## LIST OF FIGURES

<b><u>Figure</u></b>	<b><u>Page</u></b>
4-1 NGN-2 Nephelometer/Meteorology Log Sheet	7
4-2 Nephelometer Lamp Replacement Diagram	11
4-3 Datalogger Support System Front Panel	13
4-4 Diagram of the Clean Air Filter Assembly and Light Trap	17
4-5 Example Data Storage Module Quality Assurance Card	21

## LIST OF TABLES

<b><u>Table</u></b>	<b><u>Page</u></b>
1-1 Nephelometer Servicing Schedule	1
1-2 Nephelometer Station Summary of Servicing Tasks	2
4-1 Troubleshooting Procedures (Nephelometer Will Not Operate)	25
4-2 Troubleshooting Procedures (Nephelometer Malfunction During Power-On Self Test (POST))	25
4-3 Troubleshooting Procedures (Invalid or Suspect Calibration Check)	26
4-4 Troubleshooting Procedures (Error Code Displayed on Support System Front Panel)	27

## 1.0 PURPOSE AND APPLICABILITY

This technical instruction (TI) describes the steps of a routine site operator maintenance visit to an Optec NGN-2 nephelometer station operated according to IMPROVE Protocol. The purpose of routine site operator maintenance is to assure quality data capture and minimize data loss by:

- Performing weekly operational checks and preventive maintenance on nephelometers, meteorological sensors, data acquisition and control systems, and support equipment.
- Initiating an upscale (span) and zero check at every visit.
- Inspecting the clean air filter prior to the calibration check and replacing if necessary.
- Changing the Campbell storage module at two-week intervals at sites where telephone modem data collection is not possible.
- On-site troubleshooting of the NGN-2 nephelometer system.

The nephelometer servicing schedule is provided in Table 1-1.

This TI, as referenced from Standard Operating Procedure (SOP) 4100, *Nephelometer Maintenance (IMPROVE Protocol)*, specifically describes the service and maintenance procedures to be performed at nephelometer stations. A summary of the procedures is provided in Table 1-2. Tasks are listed in the suggested order of completion. For more detailed instructions, see Section 4.0.

Due to variations in the site configurations of IMPROVE Protocol sites, portions of this TI may not apply to every station.

Table 1-1

Nephelometer Servicing Schedule

INTERVAL	TASKS
Weekly Interval	Check integrity of the tower and mounting hardware. Check integrity and operation of the support system. Check operation and calibration of the ambient nephelometer. Inspect the clean air filter. Check operation of the AT/RH sensor. Complete log sheet.
2 Week Interval	Exchange storage module at sites where telephone modem data collection is not possible.
Annual Interval	Field specialists will make visits once a year to exchange the existing nephelometer for a newly serviced instrument. Training of site operators in the servicing and maintenance of the monitoring system components will take place during annual field specialist visits.

Table 1-2

Nephelometer Station  
Summary of Servicing Tasks

ORDER OF COMPLETION	SERVICING TASKS
Before leaving the office	<p>Set your digital watch to the correct time prior to leaving the office by calling the National Bureau of Standards (NBS) recording at 303/499-7111 (Boulder, CO).</p> <p>Gather all required equipment and materials (Section 3.0).</p>
Complete servicing tasks	<p>Complete the general information section on the NGN-2 Nephelometer/Meteorology Log Sheet.</p> <p>Inspect and document the condition of the support tower, guy wires, and/or other structural components.</p> <p>Verify that AC and DC power is on by inspecting the indicator lamps on the support system front panel. Replace the AC and/or DC fuse(s) if necessary.</p> <p>Document the condition of the support system and that the connectors and cables are secure and in good condition.</p> <p>Record the value displayed on the support system front panel LCD.</p> <p>Document nephelometer operational problems indicated on the support system front panel display and perform any corrective action.</p> <p>Record the 21X datalogger current AT/RH, nephelometer, and other readings by scrolling through the intermediate storage locations.</p> <p>Check the year and Julian date on the 21X datalogger; change if necessary.</p> <p>Check the time on the 21X datalogger. Reset the time if it differs from the NBS by more than one minute.</p> <p>Return the 21X datalogger to the "RUN" mode after checking or setting the time.</p> <p>Document the condition of the inlet screen and door gasket.</p> <p>Document the condition and operation of the nephelometer, fan, and clean air pump.</p> <p>Observe and document the status of the nephelometer door and lamp.</p> <p>Inspect the clean air filter and replace if necessary.</p> <p>Check the light trap for contamination and clean as required.</p> <p>Document the last span and zero calibration check by recording the values stored in the appropriate 21X datalogger intermediate storage locations as displayed on the datalogger.</p> <p>Initiate a span and zero calibration check.</p>



Table 1-2 (Continued)

Nephelometer Station  
Summary of Servicing Tasks

ORDER OF COMPLETION	SERVICING TASKS
Complete servicing tasks	<p>Observe the nephelometer Power-On Self Test (POST). Document any nephelometer functions that fail to occur.</p> <p>Document the results of the span and zero calibration check by recording the values stored in the appropriate 21X datalogger intermediate storage locations as displayed on the datalogger.</p> <p>Document the condition of the AT/RH sensor.</p> <p>Document the condition and/or operation of the wind sensors if they are present.</p> <p>Document the condition and/or operation of the AT/RH screen and aspiration fan.</p> <p>At sites where telephone modem data collection is not possible, exchange the Campbell storage module with a replacement module. Record the location, serial number, operator, and the date and time the module was removed along with the last data recorded on the module (*7 mode on the 21X) on the Storage Module Quality Assurance Card and on the NGN-2 Nephelometer/Meteorology Log Sheet.</p> <p>Record the location, serial number, operator, and the date and time the replacement module was installed on its Storage Module Quality Assurance Card.</p> <p>Complete the NGN-2 Nephelometer/Meteorology Log Sheet and note any inconsistencies. Leave the yellow copy of the log sheet in the site operator's manual and bring the white original back to the office.</p>
Back at the office	<p>Immediately fax a copy of the white original NGN-2 Nephelometer/Meteorology Log Sheet to ARS. Mail the white original log sheet along with any other documentation to ARS.</p> <p>Ship the exchanged storage module to ARS along with its Storage Module Quality Assurance Card.</p> <p>Call an ARS field specialist or data coordinator promptly if a problem or need arises.</p>

## **2.0 RESPONSIBILITIES**

### **2.1 PROJECT MANAGER**

The project manager shall:

- Coordinate with the site operator, his/her supervisor, field specialist, and data coordinator concerning the schedule and requirements for routine maintenance.
- Oversee and review documentation completed by the site operator for accuracy and completeness.

### **2.2 FIELD SPECIALIST**

The field specialist shall:

- Coordinate with the site operator, his/her supervisor, project manager, and data coordinator concerning the schedule and requirements for routine maintenance.
- Train the site operator in all phases of the routine maintenance and special servicing procedures necessary for site visits.
- Provide technical support to the site operator via telephone to assure high quality site visits.
- Document all technical support provided to the site operator.
- Resolve problems reported by the site operator.

### **2.3 DATA COORDINATOR**

The data coordinator shall:

- Coordinate with the site operator, his/her supervisor, project manager, and field specialist concerning the schedule and requirements for routine maintenance.
- Review documentation completed by the site operator for accuracy and completeness.
- Verify that scheduled visits are performed and notify the site operator if he/she fails to make a scheduled visit.
- Provide technical support to the site operator via telephone to assure high quality site visits.
- Document all technical support provided to the site operator.
- Review and file all site documentation.
- Resolve problems reported by the site operator.

- Ship cleaning and other necessary supplies for routine maintenance to the site operator.
- Enter all correspondence with site operators and the results of all performed procedures into site-specific timelines.

## **2.4 SITE OPERATOR**

The site operator shall:

- Coordinate with his/her supervisor, project manager, field specialist, and data coordinator concerning the schedule and requirements for routine maintenance.
- Perform all procedures described in this TI.
- Thoroughly document all procedures on the NGN-2 Nephelometer/Meteorology Log Sheet and fax and mail the log sheet to the data coordinator.
- Report any noted inconsistencies immediately to the data coordinator or field specialist.

## **3.0 REQUIRED EQUIPMENT AND MATERIALS**

The equipment generally required to support a weekly site visit includes:

- Medium flat-blade screwdriver
- Medium adjustable wrench
- Keys for the support system internal lock and padlocks
- Site Operator's Manual for Nephelometer Systems
- NGN-2 Nephelometer/Meteorology Log Sheet
- Pen or pencil
- Julian date calendar
- Nephelometer lamp
- Nephelometer clean air filter cartridge
- 2-amp and 7-amp AGC glass fuses
- Digital watch
- Kimwipes
- Replacement Campbell storage module (if telephone modem data collection is not possible)

## 4.0 METHODS

This section includes four (4) major subsections:

- 4.1 Routine Servicing
- 4.2 On-Site Troubleshooting
- 4.3 Problems or Questions
- 4.4 Handling Log Sheets

The procedures described in these sections refer to specific instrument components. Detailed schematic diagrams and instrument component descriptions are provided for reference in TI 4100-3350, *NGN-2 Nephelometer Monitoring System Diagrams and Component Descriptions*.

### 4.1 ROUTINE SERVICING

This subsection describes nephelometer monitoring routine servicing tasks and log sheet entries. Task descriptions are listed in the order in which they appear on the operator log sheet. Information or procedures to be followed are described with the appropriate log sheet entry (see Figure 4-1).

The nephelometer operator log sheets are divided into seven (7) main sections:

- Support Tower, Guy Wires and/or Other Structural Components
- AC and DC Power Indicator Lamps
- Datalogger
- Nephelometer
- Meteorology
- Support System
- General Comments and Supplies Needed

The following general information appears at the top of the nephelometer log sheet.

LOCATION	Enter either the full location name or the four-letter site abbreviation.
DATE	Use the standard calendar date, not the Julian date.
TIME	Current local time in 12-hour format should be used. Use Daylight Savings Time when applicable and indicate AM/PM and time zone (e.g., MST, PDT).  Before leaving the office, set your digital watch to the correct time by calling the National Bureau of Standards recording 303/499-7111 (Boulder, CO).
OPERATOR(S)	Use your full name, or use your first initial and last name.



Location \_\_\_\_\_

**NGN-2 NEPHELOMETER/METEOROLOGY LOG SHEET**

Date \_\_\_\_\_ Local Time \_\_\_\_\_ : \_\_\_\_\_ ( ) Operator(s) \_\_\_\_\_  
Weather Conditions (Temperature, Wind, Precipitation) \_\_\_\_\_  
Visibility Conditions \_\_\_\_\_

**Support Tower, Guy Wires and/or Other Structural Components**

1. Physical condition: \_\_\_\_\_

**AC and DC Power Indicator Lamps**

- Status of the red AC indicator lamp: **ON OFF** If off, replace AC fuse (2-amp) and note time \_\_\_\_\_ : \_\_\_\_\_ : \_\_\_\_\_
- Status of the green DC indicator lamp: **ON OFF** If off, replace DC fuse (7-amp) and note time \_\_\_\_\_ : \_\_\_\_\_ : \_\_\_\_\_

**Datalogger**

- General Physical Condition: \_\_\_\_\_
- The support system front panel display will show a **NEGATIVE** number to indicate certain nephelometer operating problems. If the display is approximately one of the following values, perform the action listed and note the time.

Display	Problem	Action	Time (HH : MM)
-400	Lamp burned out	Replace nephelometer lamp, then push red reset button on the support front panel for 5 seconds	_____ : _____
-500	Rain event	None required	_____ : _____
-600	Bad chopper motor frequency	Push red reset button on support system front panel	_____ : _____
-900	Serial data interface failure	Call ARS	_____ : _____

- Record the following parameters from the datalogger:

Key Sequence	Display	Measurement Parameter
*64A	04: _____	Nephelometer status code: 1 = good read (ambient), 2 = clean air (zero calibration), 3 = span calibration, 4 = lamp out, 5 = rain, 6 = chopper
A	05: _____	Nephelometer ambient reading (Reading must be > than last zero (*612A))
*68A	08: _____	Nephelometer power supply (VDC) <b>Call ARS if power is less than</b>
A	09: _____	Campbell 21X internal battery voltage (VDC) <b>12 volts or greater than 15 volts.</b>
*611A	11: _____	b <sub>scat</sub> (km <sup>-1</sup> ) or problem code. Does this match front panel display? (Call ARS if it does not)
*617A	17: _____	Nephelometer lamp intensity (counts) <b>Call ARS if counts are below 1500</b>

- Check the datalogger date and time: **Note: The 21X datalogger is always kept on Standard Time.**

- Synchronize your watch with NBS (WWW) time. (303-499-7111)
- Record time on your watch (HH:MM:SS) \_\_\_\_\_ : \_\_\_\_\_ : \_\_\_\_\_
- Record datalogger date and time:

Key Sequence	Current Display	Current time (HH:MM:SS)
*5	_____ : _____ : _____	Current time (HH:MM:SS)
A	05: _____	Year
A	05: _____	Julian date

- IF DATE IS INCORRECT OR TIME DIFFERS BY MORE THAN 1 MINUTE FROM NBS TIME, CALL ARS
- Return datalogger to run mode:

Key Sequence	Display
*0	LOG12

**Nephelometer**

- General physical condition : \_\_\_\_\_
- Condition of the inlet screen and door gasket: \_\_\_\_\_  
(If the screen or gasket is obstructed, call ARS for instructions)
- Sample fan: **ON OFF** Condition of the sample fan and fan guard: \_\_\_\_\_
- Clean air pump: **ON OFF**
- Nephelometer door: **OPEN CLOSED**
- Lamp cycling at the 2-minute ON, 3-minute OFF schedule? **YES NO**
- Inspect clean air filter: **YES NO** Replaced **YES NO** Condition of old clean air filter: \_\_\_\_\_
- Remove and inspect light trap: **YES NO** Condition of light trap: \_\_\_\_\_

Figure 4-1. NGN-2 Nephelometer/Meteorology Log Sheet.

9. Calibration - Before beginning calibration, check the \*612 and \*613 positions on the 21X datalogger (see #11 below).  
\*612A Display \_\_\_\_\_ \*613A Display \_\_\_\_\_
- Turn flowmeter off (clockwise rotation).
  - Connect the calibration gas hose to the regulator outlet.
  - Turn on the span gas tank valve (1/2 turn).
  - Press and hold the red reset button on the support system front panel for 5 seconds.  
Record the time the red reset button was pressed: \_\_\_\_\_:\_\_\_\_\_:\_\_\_\_\_
  - The nephelometer will initiate a Power-On Self Test (POST). Document that the POST functions operate correctly:
    - Door close and open: YES NO
    - Lamp and chopper on: YES NO
    - Fan on and off: YES NO
    - Solenoid on and off: YES NO
    - Clean air pump on and off: YES NO
    - Valve on and off: YES NO
    - Fan on; solenoid turns on: YES NO
    - One-minute ambient reading: YES NO
    - Door closes: YES NO
  - Adjust the span gas regulator pressure control valve to 2-4 psi. Record the pressure: \_\_\_\_\_
  - Slowly** adjust the flowmeter to approximately 20 mm on the Cole Parmer flowmeter. (Make sure the door has been closed for at least 30 seconds before adjusting the flowmeter). Record the flow value: \_\_\_\_\_ mm
  - Following the POST, the system will perform a 20-minute span calibration check, followed by a 1-minute span gas purge, followed by a 15-minute clean air zero calibration check.
  - When the nephelometer door opens (36 minutes after starting the span calibration check) the span and zero calibration checks are complete.
10. TURN THE SPAN GAS TANK VALVE FULLY OFF. Disconnect the calibration gas hose at the regulator outlet to bleed excess gas from the hose, and turn the flowmeter off (clockwise rotation).
11. Record the results of the zero and span calibration checks from the datalogger:
- | <u>Key Sequence</u> | <u>Display</u> | <u>Measurement Parameter</u>   |
|---------------------|----------------|--|
| *612A               | 12: _____      | Last zero calibration check (counts)   |
| A                   | **13: _____    | Last span calibration check (counts) **This number should be slightly different than the *613A reading taken before the calibration check. |

**Meteorology** (Air Temperature/Relative Humidity Sensor; Wind Speed and Wind Direction Sensors)

- General physical condition: \_\_\_\_\_
- Wind sensors unobstructed and free moving: YES NO Comment if NO: \_\_\_\_\_
- AT/RH aspiration fan operating: YES NO Condition of the AT/RH screen: \_\_\_\_\_
- Record the following meteorological parameters from the datalogger: (Note - not all sites have wind speed and wind direction sensors)

<u>Key Sequence</u>	<u>Display</u>	<u>Measurement Parameter</u>
*61A	01: _____	Ambient temperature (C)
A	02: _____	Ambient relative humidity (%)
*652A	52: _____	Wind speed (mph)
A	53: _____	Wind direction (degrees true)
- Datalogger values reasonable for current conditions: YES NO Comment: \_\_\_\_\_

**Support System**

1. If required, exchange the Campbell SM716 or SM192 storage module with a new one. Record the following:

	<u>Old module</u>	<u>New module</u>
Model (SM192, SM716)	_____	_____
Serial number	_____	_____
Time removed/installed (HH:MM)	_____:_____	_____:_____

- Complete removal information on the old module's Quality Assurance Card and installation information on the new card.
- Check all connectors.
- Call ARS immediately if you have any problems or questions.

**General Comments and Supplies Needed**

\_\_\_\_\_  
\_\_\_\_\_  
\_\_\_\_\_

FAX and mail the original white 2-page log sheet to:  
Leave yellow copy on-site

Air Resource Specialists, Inc.  
Attn: Data Coordinator  
1901 Sharp Point Drive, Suite E  
Fort Collins, CO 80525

Phone: 970-484-7941  
Fax: 970-484-3423

Figure 4-1. (Continued). NGN-2 Nephelometer/Meteorology Log Sheet.

WEATHER  
CONDITIONS

Describe current or recent weather conditions that may be helpful in interpreting the nephelometer readings. Such conditions may include, but are not limited to:

- Passing storm fronts
- Impending precipitation
- Precipitation events
- Stagnant air masses
- High winds
- Fog

VISIBILITY  
CONDITIONS

Describe current or recent visibility conditions that may be useful in verifying correct nephelometer operation. A partial list of such conditions includes:

- Extremely clean
- Regional haze
- Layered haze
- Plumes visible
- Severity of haze
- Emission source activity (e.g., nearby forest fires, controlled burns, construction, dusty roads, residential wood burning, etc.)
- Any perceptible odors (e.g., wood smoke)

**4.1.1 Support Tower, Guy Wires, and/or Other Structural Components**

PHYSICAL  
CONDITION

Check the integrity of the tower and mounting hardware including tower stability, guy wire tension, tightness of mounting bolts and nuts, and aesthetic conditions. Document any problems and promptly telephone ARS.

**4.1.2 AC and DC Power Indicator Lamps**

RED AC  
INDICATOR  
LAMP

The red indicator lamp on the front panel of the support system indicates whether or not AC power is reaching the support system. If the lamp is not illuminated, check for the following:

- Power is turned off at the main breaker box.
- The support system is not plugged in.
- The AC fuse on the front panel is blown.

If the AC fuse is blown, replace it with a 2-amp, AGC, fast-blow glass fuse. Upon replacement of the fuse, the nephelometer should begin its Power-On Self Test and span/zero sequence. If the fuse blows again, do not replace it. Call ARS immediately whenever a fuse has blown.

## GREEN DC INDICATOR LAMP

The green indicator lamp on the front panel of the support system indicates whether or not the main 13.8 volt DC power supply is operating. The DC power supply provides power to operate the nephelometer. The datalogger is powered by its own rechargeable internal battery. If the green indicator lamp is not illuminated, check for the following:

- The Red AC indicator lamp is not illuminated; AC power must be available to the DC power supply.
- The DC fuse on the front panel is blown.

If the DC fuse is blown, replace it with a 7-amp AGC fast-blow glass fuse. Upon replacement of the fuse, the nephelometer should begin its Power-On Self Test and span/zero sequence. If the fuse blows again, do not replace it. Call ARS immediately whenever a fuse has blown.

### 4.1.3 Datalogger

Datalogger condition and function should both be checked, as follows:

#### GENERAL PHYSICAL CONDITION

Describe any accumulation of dirt or other contamination, damage, or other physical problems regarding the support system or its mounting hardware.

#### SUPPORT SYSTEM DISPLAY

The support system front panel display usually indicates the ambient scattering value calculated from the last ambient nephelometer reading. However, if the nephelometer automatically suspends its operation due to a detected precipitation event or if the instrument fails, the display will indicate an error code (negative number) that may assist in troubleshooting the instrument. Record the displayed value on the log sheet.

**Promptly call ARS if an error code is noted on the display.**

#### **Error Code -400: Nephelometer Lamp Burned Out**

Replace the lamp as described below (refer to Figure 4-2):

BE CAREFUL, THE LAMP MAY BE HOT.

NEVER TOUCH THE LAMP GLOBE WITH BARE FINGERS;  
SKIN OILS MAY CAUSE THE LAMP TO FAIL OR BREAK.

- The nephelometer lamp is accessed via a rectangular bracket on the back of the nephelometer.
- Disconnect the gray cable going into the back of the bracket at the black, twist-off connector.
- Remove the two black knobs securing the nephelometer lamp bracket.



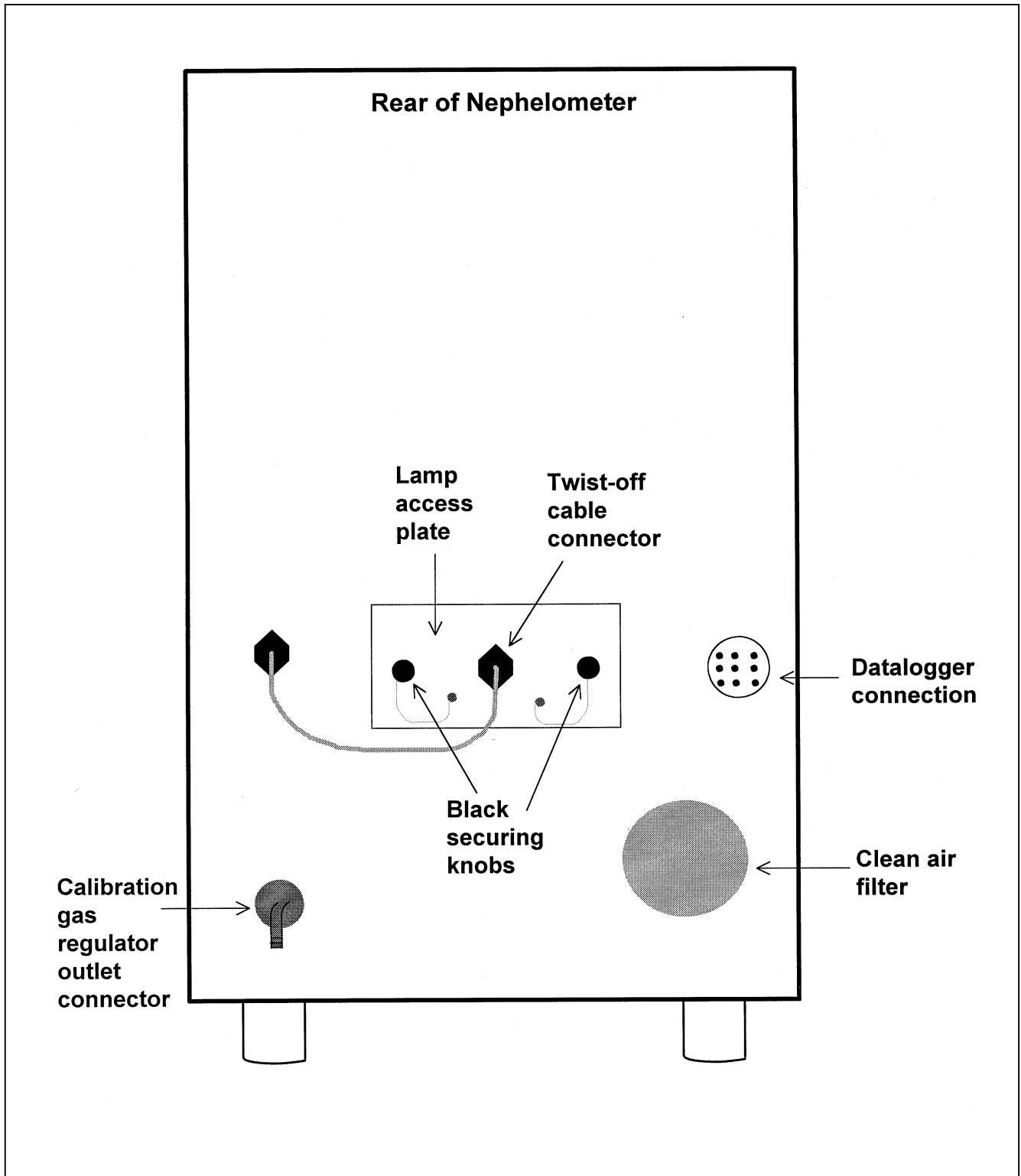

Figure 4-2. Nephelometer Lamp Replacement Diagram.

- Carefully slide the lamp bracket out of the nephelometer.
- Slide the lamp up and out of the bracket and disconnect it from the lamp socket.
- Insert the new lamp into the lamp socket and slide it into the lamp bracket. Be sure that the lamp is properly seated in the socket.
- Carefully slide the lamp bracket into the nephelometer.
- Reinstall the two black knobs.
- Reconnect the gray cable to the back end of the bracket.

Reset the nephelometer by pressing the red pushbutton on the support system front panel for five seconds (refer to Figure 4-3). The nephelometer will initiate its Power-On Self Test and span/zero sequence (see Section 4.1.4). Document the time the nephelometer was reset.

**Error Code -500: Rain Event**

The nephelometer sensed a precipitation event and has shut down until the precipitation sensor is dry. Ambient readings will automatically resume when the sensor is dry; no operator intervention is required.

**Error Code -600: Bad Chopper Motor Frequency**

The nephelometer was unable to keep the frequency of the chopper motor within tolerance.

Reset the nephelometer by pressing the red pushbutton on the support system front panel for five seconds (refer to Figure 4-3). The nephelometer will initiate its Power-On Self Test (POST) and span/zero sequence (see Section 4.1.4). If the nephelometer fails to initiate the POST, call ARS for instructions. Document the time the nephelometer was reset.

**Error Code -900: Serial Data Interface Failure**

The 21X datalogger was unable to capture the serial data stream from the nephelometer. The most likely cause is a failure of the serial interface subsystem in the support system. Call ARS for instructions.

CABLES  
AND  
CONNECTORS

The support system cables connect the support system to the nephelometer, AT/RH sensor, AC power, telephone line, DCP (if present), and computer interface (if present) through connectors on the bottom of the enclosure. Check the cables and connectors. Verify that all cables are secure and check the integrity of the cables. Document any problems, including broken connectors, loose or bare wires, etc. Report any problems promptly to ARS.

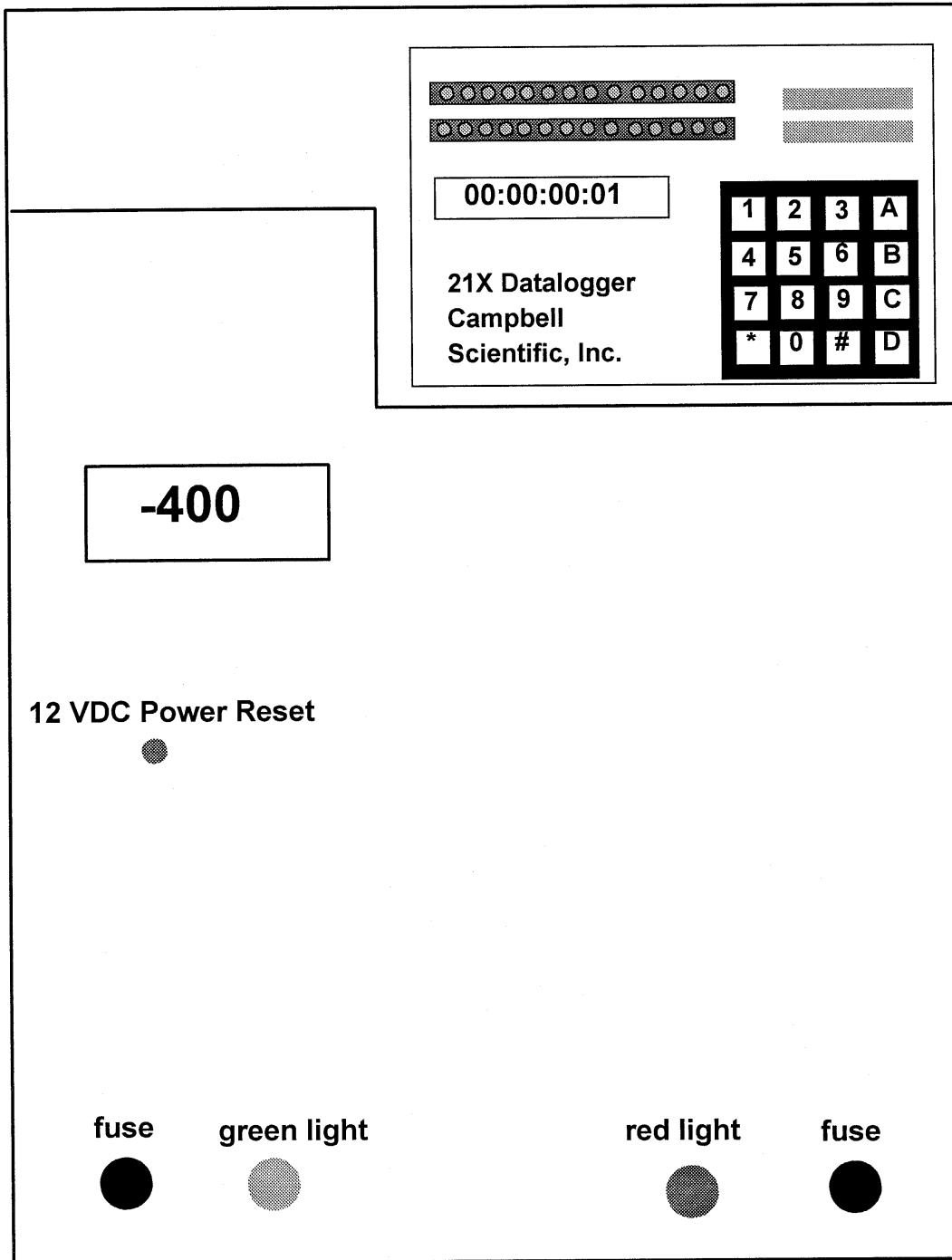

Figure 4-3. Datalogger Support System Front Panel.

## CAMPBELL DATALOGGER FUNCTIONS

The Campbell 21X datalogger samples and stores the following data:

- Nephelometer serial outputs
- Rotronics AT/RH sensor outputs
- DC power supply voltage
- Date and time

The 21X also performs the following functions:

- Provides power to the nephelometer interface board
- Calculates ambient  $b_{\text{scat}}$  from nephelometer raw readings
- Drives the support system front panel display
- Stores data in the storage module
- Provides an analog output signal to the DCP (if present)
- Allows downloading of data via phone modem

## DATALOGGER STORAGE LOCATIONS

Log the following current readings from the 21X datalogger intermediate storage locations by entering \*6 on the 21X keyboard to access the locations, and entering A to advance through the locations.

<u>Key Sequence</u>	<u>Display</u>	<u>Measurement Parameter</u>
*64A	04:_____	Nephelometer status code: 1=good read mbient), 2=clean air (zero calibration), 3=span calibration, 4=lamp out, 5=rain, 6=chopper
A	05:_____	Nephelometer ambient reading (Reading must be greater than last zero (*612A))
*68A	08:_____	Nephelometer power supply (VDC)
A	09:_____	Campbell 21X internal battery voltage (VDC)
*611A	11:_____	$b_{\text{scat}}$ ( $\text{km}^{-1}$ ) or problem code. Does this match the front panel display?
*617A	17:_____	Nephelometer lamp intensity (counts)

## VERIFY OPERATOR WATCH SET TO NBS TIME

The 21X datalogger time should be set to **local standard time** synchronized to NBS time. The operator should set his/her watch to NBS local standard time by calling 303/499-7111. Indicate on the log sheet if time is synchronized to NBS time.

## CHECKING AND SETTING THE DATE AND TIME

The 21X datalogger keeps track of the date in Julian date and year format. The date and time functions are accessed by entering \*5 on the 21X keyboard and entering A to advance through the parameters.

**Checking the time**

Access the 21X time mode by entering \*5 on the 21X keyboard. Record both the 21X time and the NBS time on the log sheet.

**The 21X datalogger time should only be set if it differs by more than one minute from NBS time.**

**Setting the time**

Advance to the time set display by entering \*5AAA. Enter the correct time at the top of a minute as HH:MM and press A to input the change. Record the time entered on the log sheet. Press \*5 to verify that the time change was entered properly and is now synchronized with NBS time.

**Checking and setting the year**

Advance to the year by entering A and record the year. If the year is incorrect, enter the correct year on the keyboard and press A to input the change. Record the year entered on the log sheet.

**Checking and setting the Julian date**

Advance to the Julian date by entering A and record the Julian date. If the Julian date is incorrect (refer to a Julian date calendar), enter the correct Julian date on the keyboard and press A to input the change. Record the Julian date entered on the log sheet.

PLACING  
IN RUN  
MODE

Enter \*0 on the 21X keyboard to place the 21X in the "RUN" mode. The 21X display will show "LOG12" to indicate correct operation. If the 21X does not display "LOG12," call ARS immediately for instructions.

**4.1.4 Nephelometer**

The condition and function of the nephelometer and its components should be checked as follows:

GENERAL  
PHYSICAL  
CONDITION

Describe any accumulation of dirt, contamination, damage, or other physical problems regarding the nephelometer or its mounting system.

INLET SCREEN  
AND DOOR  
GASKET

The nephelometer inlet screen keeps insects and large debris from entering the measurement chamber. The door gasket creates a tight seal when the door closes for span and clean air zero calibrations. Document the condition of the nephelometer inlet screen and door gasket. Note excess dirt, snow, ice, or foreign materials. Remove any obstructions from the screen and/or door gasket. If either the screen or the gasket are very dirty, damaged, or severely obstructed, call ARS for instructions.

SAMPLE FAN  
AND FAN  
GUARD

The nephelometer sample fan draws ambient air in through the inlet screen and exhausts it past the fan guard on the bottom of the instrument. Listen to the fan and feel for the air flow out of the fan. Document any problems (fan not running, noisy, clogged, etc.). Inspect the fan guard and brush off any insects or accumulated debris. Document the condition of the fan and fan guard.

CLEAN AIR  
(ZERO)  
PUMP

The nephelometer clean air pump recirculates air within the measurement chamber through a 0.3-micron filter to remove particles from the air. The clean air pump is on and the door is closed during automatic clean air zero calibrations and during power-up span/zero checks. The pump makes a low frequency hum distinct from the sound of the sample fan. Document whether the pump is on or off.

INITIAL  
DOOR  
POSITION

The position of the nephelometer door indicates whether the instrument is taking ambient readings, performing an automatic clean air calibration, or has failed. Ambient readings are taken when the door is open. The nephelometer performs a 15-minute automatic clean air calibration at pre-programmed intervals (e.g., every 6 or 30 hours). The door remains closed during this period. The nephelometer will also automatically go through a Power-On Self Test and 35-minute span/zero sequence every time power is interrupted and restored to the unit. The door also remains closed for a majority of the span/zero sequence. If the door is closed upon arrival at the site, WAIT for 15 minutes before determining whether the nephelometer has failed. If the nephelometer has failed, an error code may be displayed on the support system front panel display (see error code descriptions below). Document the position of the door.

LAMP  
STATUS

When the door is open and all components are operating properly, the nephelometer takes a two-minute reading with the lamp on, followed by a three-minute period with the lamp off. The door is open and the fan is on during the entire five-minute period. The lamp will appear to flash as the light is chopped by an internal motor. Verify that the lamp cycles according to the two-minute-on/three-minute-off schedule and that it is flashing. Document the operation of the lamp.

CLEAN AIR  
FILTER

Inspect the clean air filter cassette (refer to Figure 4-4):

- Remove (unscrew by hand) the entire filter assembly from the nephelometer.
- Remove (unscrew by hand) the retainer cap from the back of the assembly.
- Remove (unscrew by hand) the filter cassette and replace with a new cassette, if necessary.

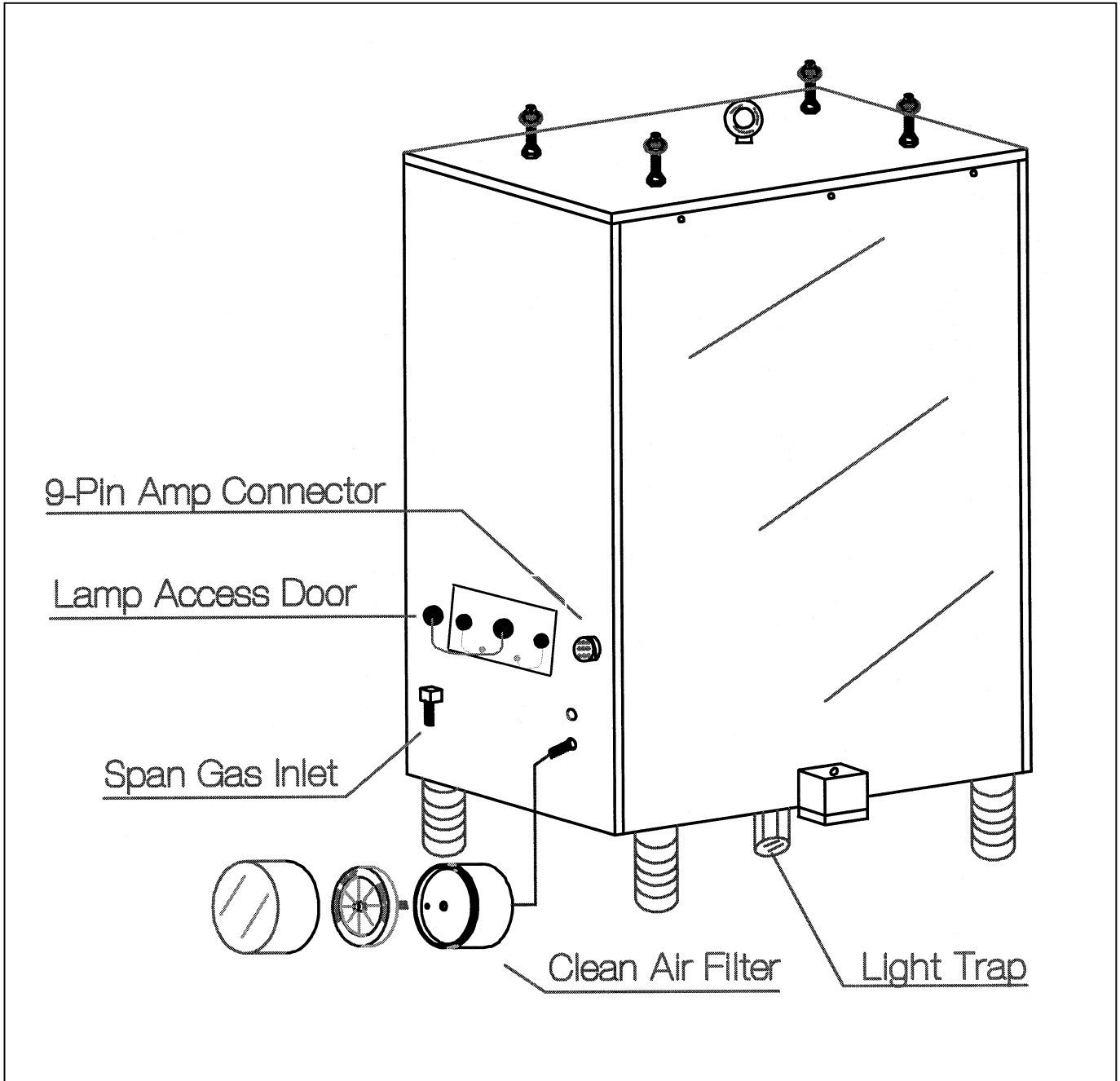

Figure 4-4. Diagram of the Clean Air Filter Assembly and Light Trap.

- Replace all parts in reverse order.
- Note the condition of the old filter (dirt, moisture, etc.).

#### LIGHT TRAP

Unthread (unscrew by hand) the light trap (refer to Figure 4-4). Note if any water or dirt is found inside the light trap. Clean with a Kimwipe or equivalent if necessary. Replace the light trap and hand tighten.

#### CALIBRATION PREPARATION

The nephelometer will perform a Power-On Self-Test (POST) followed by an automatic upscale and zero check when it is powered up or when the red pushbutton on the support system front panel is pressed. The upscale check is performed with SUVA 134a gas, which has a specific span value. Hence the check is commonly referred to as a span check. To prepare for the calibration sequence:

- Before starting the calibration, record the zero value from location "12" on the 21X datalogger by entering \*612A on the datalogger keyboard. Advance to the upscale/span value in location "13" by entering A. Record the span value.
- Turn the flowmeter off by turning the black knob in a clockwise rotation.
- Connect the flowmeter input hose (bottom) to the calibration gas regulator outlet connector (see Figure 4-2).
- Turn on the calibration gas tank valve (1/2 turn).
- Reset the nephelometer by pressing and holding the red pushbutton on the front panel of the support system for five seconds. Record the 21X datalogger time (\*5) the nephelometer was reset on the log sheet. The calibration sequence will begin.

#### **Power-On Self Test (POST)**

The POST sequence is as follows:

- Door closes
- Door opens
- Lamp turns on
- Fan turns on and off
- Internal solenoid turns on and off
- Clean air pump turns on and off
- Internal calibration gas valve turns on and off



- Fan turns on, solenoid turns on
- One-minute sample reading is taken
- Lamp turns off and door closes

### **Span and Zero Calibration**

Following the POST, the span/zero sequence begins. The 20-minute span check occurs first, followed by a one-minute calibration gas purge, followed by a 15-minute clean air zero check. The span check requires that a source of calibration gas is available to the nephelometer during the calibration process. At the end of the 36 minutes, the span and zero values are available on the Campbell 21X datalogger. Carry out the following procedures to initiate a span and zero check:

- Observe the Power-On Self Test (POST). Document whether or not the POST was successful.
- At the beginning of the span gas calibration, adjust the regulator output pressure to 2 to 4 psi and record the pressure.
- Slowly open the flowmeter valve, increasing the flow to approximately 2 lpm (corrected). Use settings of approximately 20 mm when using the suggested Cole Parmer flowmeter. Make sure the door has been closed for at least 30 seconds before adjusting the flowmeter. Check the individual flowmeter calibration for the actual value. Record the flow value on the log sheet. Note that the flowmeter value could vary as much as  $\pm 5$  mm throughout the calibration. This level of variation is acceptable.
- Wait 36 minutes for the span and zero to occur. The nephelometer door will open when the check is complete.
- Upon completion of the calibration, **TURN THE SPAN GAS TANK VALVE COMPLETELY OFF.** Disconnect the calibration gas hose at the regulator outlet to bleed excess gas from the hose.
- Record the zero value from location "12" on the 21X datalogger by entering **\*612A** on the datalogger keyboard. Advance to the span value in location "13" by entering **A**. Record the span value.
- Enter **\*0** on the datalogger keyboard to place the datalogger in the "RUN" mode. The display will show "LOG12" to indicate correct operation.

The nephelometer will begin operating in ambient "RUN" mode upon completion of the span and zero check.

#### 4.1.5 Meteorology

The condition and functions of meteorological sensors, including air temperature, relative humidity, and wind sensors should be checked as follows:

**GENERAL PHYSICAL CONDITION** Describe any accumulation of dirt or other contamination, damage, or other physical problems regarding the AT/RH sensor, housing, or its mounting system. Remove any accumulation of snow or ice from the housing.

**WIND SENSORS** If available at sites, verify that wind sensors are unobstructed and that they are free-moving.

**ASPIRATION FAN** The AT/RH sensor aspiration fan eliminates the effect of heating of the housing and assures that the AT/RH sensor is measuring ambient air. The fan must always be running. Document the status of the aspiration fan and call ARS promptly if the fan is not functioning.

**HOUSING SCREEN** The AT/RH housing screen keeps insects and debris out of the housing and away from the sensor. Remove foreign matter from the screen and record the condition of the screen.

**RECORD CURRENT CONDITIONS** Record the following current meteorological parameters from the 21X datalogger by entering \*6 on the 21X keyboard to access the parameters, and entering A to advance through the locations.

<u>Key Sequence</u>	<u>Display</u>	<u>Measurement Parameter</u>
*61A	01:_____	Ambient temperature (°C)
A	02:_____	Ambient relative humidity (%)
*652A	52:_____	Wind speed (mph)
A	53:_____	Wind direction (degrees true)

Comment and document if the datalogger recorded meteorological conditions appear similar with current conditions observed at the site.

#### 4.1.6 Support System

The Campbell storage module is the backup data storage medium at sites with a telephone modem. The storage module must be exchanged only upon instruction from ARS. The module will be used to fill in gaps in the data collected via telephone modems.

The Campbell storage module is the primary data storage medium at sites without a telephone modem. At these sites the DCP provides near-real time monitoring of the nephelometer system. At sites without a telephone modem, the storage module must be exchanged twice a month on the first and third visit of each month, in conjunction with the operator initiated span/zero checks.

**STORAGE MODULE REMOVAL** Record the following information on the old module's Storage Module Quality Assurance Card (an example card is provided as Figure 4-5):

<b>DATA STORAGE MODULE QUALITY ASSURANCE CARD</b>	
-----	
Location	_____
Module SN	_____
Init.	_____ by _____
Fill/	_____
Full/Replace by	_____
-----	
Date on	_____
Time on	_____ ( )
Installed by	_____
-----	
Date off	_____
Time off	_____ ( )
Removed by	_____
-----	
Comment	_____
PGM in #8	_____
PGM in #8	_____

Figure 4-5. Example Data Storage Module Quality Assurance Card.

- Location
- Storage module model number (SM192 or SM716)
- Storage module serial number
- Operator
- Date and time of removal

Also record the serial number and time of removal on the log sheet.

#### STORAGE MODULE INSTALLATION

Upon installation of a new storage module, record the following information on the new module's Storage Module Quality Assurance Card:

- Location
- Storage module model number (SM192 or SM716)
- Storage module serial number
- Operator
- Date and time of installation

Also record the serial number and time of installation on the log sheet.

#### CHECK CONNECTIONS

Verify that the new module is connected fully and properly. Call ARS if problems occur.

#### SEND MODULE TO ARS

Promptly ship the removed storage module to ARS in the supplied shipping container. A replacement module will be returned in time for the next exchange.

#### **4.1.7 General Comments and Supplies Needed**

Document any unusual finding or problem experienced while performing the instrument checks. Also state any additional supplies needed.

### **4.2 ON-SITE TROUBLESHOOTING**

#### **4.2.1 General Troubleshooting Information**

Nephelometer troubleshooting is normally initiated by either the site operator (in response to a problem observed during routine site servicing) or by the data coordinator in the ARS Data Collection Center (in response to operational problems detected during daily review of nephelometer data). A good practice to follow when troubleshooting a problem in the field is to start with the simple checks and progress toward the more complicated.

The majority of nephelometer problems are due to:

- Moisture in the nephelometer light trap and/or clean air filter.
- Nephelometer lamp malfunction.
- Electrical power outages or surges.
- Lightning induced voltage spikes on the telephone line.

In most cases, site operators can diagnose and solve instrument problems in the field, reducing costly site visits and minimizing data loss. In a few cases, an instrument or component malfunction that cannot be corrected in the field will be diagnosed and the instrument will need to be removed and returned to ARS for repair.

#### TROUBLE- SHOOTING

The source of most nephelometer system problems can be identified in the field by checking items in the following categories:

- Obvious Sources:
  - Moisture is in the light trap and/or clean air filter.
  - The lamp is burned out or operates intermittently.
  - The nephelometer door is malfunctioning (the door remains closed or open continually).
  - A malfunction exists in the calibration gas flowmeter or pressure regulator.
  - The calibration gas tank is empty or the valve will not open.
  - Electrical power is unplugged or is not turned on.
  - The telephone line/blue ribbon cables are not connected properly to the datalogger, modem, teletype, or storage module.
- Power Supply:
  - A fuse is blown in the datalogging and control subsystem enclosure.
  - The power connectors are not making good contact.
- Connectors:
  - A connector is not plugged in, or is in the wrong input position.
  - A connector is not making good contact.

- Connector pins or sockets are damaged.
- Moisture is in the connector.
- The cable/connector is damaged, resulting in broken wire or electrical short.

**BEFORE  
CALLING  
FOR  
ASSISTANCE**

Before reporting problems or requesting assistance in diagnosing an instrument problem, please do the following:

- Before leaving the nephelometer, be sure to perform and document the results of all instrument and support system checks specified on the NGN-2 Nephelometer/Meteorology Log Sheet.
- Check problem areas listed above (Obvious Sources, Power Supply and Connectors).
- Follow procedures for troubleshooting the observed problem (see Section 4.2.2).
- Have documentation of your tests available.
- Have a site operator's manual available.

Please call promptly with suspected or observed instrument problems. If the person you need to speak with is not in, ask to be directed to another or leave a message, including your name, location, telephone number, and a brief description of the problem(s) or need(s).

**4.2.2 Specific Troubleshooting Procedures**

On-site symptoms of a malfunctioning nephelometer system that would be observed by the site operator during a routine site visit can be grouped into the following categories:

- Nephelometer will not operate - the system does not appear to be operating and will not respond to system reset.
- Nephelometer malfunctions during Power-On Self Test (POST) - after resetting the system, the system fails to complete all tests conducted during the POST.
- Nephelometer span/zero calibration check is invalid or suspect - calibration check data are inconsistent with previous calibration check data.
- System error code is displayed on support system front panel - the support system has detected and identified an operational error.

Tables 4-1 through 4-4 list specific instrument, component, or procedural problems that can produce the symptoms described above. For each problem listed, the appropriate corrective action is described and reference is made to the section of this TI that provides detailed information for performing the specified corrective action.

Table 4-1

Troubleshooting Procedures  
(Nephelometer Will Not Operate)

NEPHELOMETER WILL NOT OPERATE		
Symptom	Problem	Corrective Action
The DC power indicator light (green) on the support system front panel is "OFF."	Blown fuse	Replace fuse - 7 amp AGC (refer to Section 4.1.2, AC and DC Power).
The AC power indicator light (red) on the support system front panel is "OFF."	Blown fuse	Replace fuse - 2 amp, AGC (refer to Section 4.1.2, AC and DC Power).
	No AC power to support system	Check AC power connection.
The Uninterruptible Power Supply (UPS) "line on" and "backup on" indicator lights are "OFF."	No AC power to UPS	Check AC power connection for UPS power cable.

Table 4-2

Troubleshooting Procedures  
(Nephelometer Malfunction During Power-On Self Test (POST))

NEPHELOMETER MALFUNCTION DURING POWER-ON SELF TEST (POST)		
Symptom	Problem	Corrective Action
The nephelometer door does not close completely.	Door obstructed	Inspect the door gasket and remove any obstructions (refer to Section 4.1.4, Nephelometer).
	Reset button malfunction	Disconnect the nephelometer DC power cable at the support system. Wait 5 seconds and reconnect. Document results and call ARS.
	Door motor or door motor control system malfunction	Call ARS.
The nephelometer door does not open properly.	Lamp out	Check and document the error code on the support system display. If the code is "-400," replace the lamp (refer to Section 4.1.3, Datalogger). If the door still will not open, call ARS.

Table 4-3

Troubleshooting Procedures  
(Invalid or Suspect Calibration Check)

INVALID OR SUSPECT CALIBRATION CHECK		
Symptom	Problem	Corrective Action
Invalid or suspect clean air calibration.	Dirt or moisture in light trap	Clean the light trap (refer to Section 4.1.4, Nephelometer).
	Moisture in clean air filter	Replace the clean air filter (refer to Section 4.1.4, Nephelometer).
	Clean air pump malfunction	Verify that the clean air pump is operating (refer to Section 4.1.4, Nephelometer). If the pump is not operating, call ARS.
	Air leak around nephelometer door	Clean and remove any obstructions from the door gasket (refer to Section 4.1.4, Nephelometer).
	Air leak around clean air filter housing unit	Replace the clean air filter (refer to Section 4.1.4, Nephelometer).
	Dirty chamber	Check for pollen, bugs, spiders. Document finding and call ARS.
Low span (upscale) calibration check.	Adequate supply of calibration gas not getting into nephelometer chamber	Check control settings and connections, span gas tank valve, pressure regulator, hoses, and flowmeter (refer to Section 4.1.4, Nephelometer).
	Empty span gas tank	Check the tank and call ARS if it is low or empty.
	Air leak around nephelometer door	Clean and remove any obstructions from the door gasket (refer to Section 4.1.4, Nephelometer).
	Clean air pump malfunction	Verify that the clean air pump is operating (refer to Section 4.1.4, Nephelometer). If the pump is not operating, call ARS.
High span (upscale) calibration check.	Span gas flow too high	Check the flowmeter adjustment (refer to Section 4.1.4, Nephelometer).
	Condensation in chamber due to gas flow starting too quickly	Repeat the span/zero calibration check. Be especially careful to open the flowmeter valve <b>slowly</b> .
	Dirt or moisture in light trap	Clean the light trap (refer to Section 4.1.4, Nephelometer).
	Moisture in clean air filter	Replace the clean air filter (refer to Section 4.1.4, Nephelometer).



Table 4-4

Troubleshooting Procedures  
(Error Code Displayed on Support System Front Panel)

ERROR CODE DISPLAYED ON SUPPORT SYSTEM FRONT PANEL		
Symptom	Problem	Corrective Action
Error Code -400	Lamp out	Replace lamp (refer to Section 4.1.3, Datalogger).
Error Code -500	Rain event	No operator intervention is required. Readings will resume when the sensor is dry.
Error Code -600	Incorrect chopper frequency	Reset the system by pressing the red reset button on the support system front panel (refer to Section 4.1.3, Datalogger).
Error Code -900	Serial data interface failure	Follow the procedures described in Section 4.1.3, Datalogger.

### 4.3 PROBLEMS OR QUESTIONS

Call ARS immediately if any problems occur or if any questions arise. Many problems can be resolved through telephone consultation.

ARS may be reached at the following telephone numbers:

Regular: 970/484-7941  
Fax: 970/484-3423

### 4.4 HANDLING LOG SHEETS

The site operator must complete a nephelometer operator log sheet for each site visit. Upon returning to the office, fax the completed two-page log sheets to ARS (Fax 970/484-3423).

Also mail the original log sheets to ARS:

Air Resource Specialists, Inc.  
Attn: Data Coordinator  
1901 Sharp Point Drive Suite E  
Fort Collins, CO 80525

Any additional information or other pertinent supplemental documentation that the operator deems important can also be included with the log sheets.

QUALITY ASSURANCE/QUALITY CONTROL DOCUMENTATION SERIES	
TITLE	<b>NGN-2 NEPHELOMETER MONITORING SYSTEM DIAGRAMS AND COMPONENT DESCRIPTIONS</b>
TYPE	<b>TECHNICAL INSTRUCTION</b>
NUMBER	<b>4100-3350</b>
DATE	<b>JANUARY 1994</b>

AUTHORIZATIONS		
TITLE	NAME	SIGNATURE
ORIGINATOR	D. Scott Cismoski	
PROJECT MANAGER	James H. Wagner	
PROGRAM MANAGER	David L. Dietrich	
QA MANAGER	Gloria S. Mercer	
OTHER		

REVISION HISTORY			
REVISION NO.	CHANGE DESCRIPTION	DATE	AUTHORIZATIONS
1.0	Add span gas system/modify wire diagrams	October 1996	

## TABLE OF CONTENTS

<u>Section</u>	<u>Page</u>
1.0 PURPOSE AND APPLICABILITY	1
2.0 RESPONSIBILITIES	1
2.1 Project Manager	1
3.0 REQUIRED EQUIPMENT AND MATERIALS	1
4.0 METHODS	1
4.1 Optec NGN-2 Nephelometer	2
4.1.1 Nephelometer Configuration	2
4.1.2 Nephelometer Exterior and Cross-Sectional View Diagrams	2
4.2 Gas Calibration System	2
4.3 Data Logging and Control Subsystem	5
4.3.1 Major Sub-Components	5
4.3.2 Definitions of Wiring Abbreviations	7
4.3.3 Connector Panel Connector Locations	8
4.3.4 Connector Panel Wiring	8
4.3.5 Interface Circuit Board	8
4.3.6 Front Panel Wiring	8
4.3.7 AC Wiring	15
4.3.8 13.8 VDC Power Supply	16
4.3.9 Campbell 21X Datalogger Wiring	16
4.3.10 Nephelometer Power and Signal Cable	18
4.4 Shielded and Aspirated Rotronics Ambient Temperature and Relative Humidity Sensor	19
4.4.1 Major Components	19
4.4.2 Rotronics AT/RH Sensor and Aspiration Fan Connector and Cable	21
4.5 Support Tower and Related Hardware	22
4.5.1 Major Components	22
4.5.2 Tower-Related Components	22
4.5.3 Wall Mount Option	22
4.6 Precipitation and Solar Radiation Shield	22
5.0 REFERENCES	25

## LIST OF FIGURES

<b><u>Figure</u></b>	<b><u>Page</u></b>
4-1 Optec NGN-2 Nephelometer Exterior Diagram	3
4-2 Optec NGN-2 Nephelometer Cross-Sectional View	3
4-3 Span Gas Calibration System	4
4-4 Data Logging and Control Subsystem Component Locations	6
4-5 Data Logging and Control Subsystem Connector Panel	8
4-6 Interface Circuit Board Layout	10
4-7 Datalogger Support System Front Panel	14
4-8 Data Logging and Control Subsystem AC Wiring Diagram	15
4-9 Campbell Scientific 21X Datalogger	17
4-10 Rotronics AT/RH Sensor in Force-Aspirated Shield	20
4-11 Nephelometer Support Tower and Related Hardware	23
4-12 Precipitation and Solar Radiation Shield for Optec NGN-2 Nephelometer	24
4-13 Precipitation Hood Installation Diagram	25

## LIST OF TABLES

<b><u>Table</u></b>	<b><u>Page</u></b>
4-1 Nephelometer 9-Pin Connector Description	4
4-2 Major Components of the Data Logging and Control Subsystem	5
4-3 Connector Panel Connector Wiring	9
4-4 Interface Circuit Board (CB) Connector Functions	11
4-5 Interface Circuit Board Connector Wiring	12
4-6 Major Components on the Data Logging and Control Subsystem Front Panel	14
4-7 Major Components of AC Wiring for Data Logging and Control Subsystem	15

**LIST OF TABLES (CONTINUED)**

<b><u>Table</u></b>	<b><u>Page</u></b>
4-8 13.8 VDC Power Supply Terminal Strip Wiring	16
4-9 Campbell 21X Datalogger Wiring Description	18
4-10 Nephelometer Power and Signal Cable	19
4-11 Major Components of the Shielded and Aspirated Rotronics AT/RH Sensor System	21
4-12 Rotronics AT/RH Sensor and Aspiration Fan Connector and Cable Wiring	21

## **1.0 PURPOSE AND APPLICABILITY**

This technical instruction (TI) describes the individual components of an IMPROVE NGN-2 nephelometer station, including:

- An Optec NGN-2 nephelometer.
- A gas calibration system.
- A data logging and control subsystem.
- A shielded and aspirated Rotronics ambient temperature and relative humidity sensor.
- A support tower and related hardware.
- A precipitation and solar radiation shield.

The descriptions in this TI may be used to build and/or troubleshoot the nephelometer system. Components in the system may change depending on site logistics, component availability, and construction. This technical instruction includes the following information:

- A brief description of component function
- Component model, manufacturer, and supplier
- System component diagrams
- Cable and connector descriptions
- Wiring diagrams and tables

## **2.0 RESPONSIBILITIES**

### **2.1 PROJECT MANAGER**

The project manager shall ensure that the component descriptions in this TI are accurate, complete, and up-to-date.

## **3.0 REQUIRED EQUIPMENT AND MATERIALS**

None.

## **4.0 METHODS**

This section describes the system components and wiring of a nephelometer station and includes six (6) major subsections:

- 4.1 Optec NGN-2 Nephelometer
- 4.2 Gas Calibration System
- 4.3 Data Logging and Control Subsystem
- 4.4 Shielded and Aspirated Rotronics Ambient Temperature and Relative Humidity Sensor
- 4.5 Support Tower and Related Hardware
- 4.6 Precipitation and Solar Radiation Shield

## **4.1 OPTEC NGN-2 NEPHELOMETER**

This section provides a brief overview of the Optec NGN-2 nephelometer. Detailed component descriptions for the nephelometer are provided in *Model NGN-2 Open-Air Integrating Nephelometer Technical Manual for Theory of Operation and Operating Procedures* (Optec, 1993). The NGN-2 uses a unique design that allows accurate measurement of the scattering component of ambient air. Extinction due to scatter can accurately be measured from Rayleigh to 100% saturated fog conditions.

### **4.1.1 Nephelometer Configuration**

The nephelometer configuration is determined by the version of EPROM installed and user-selectable parameters stored in battery-backed RAM in the instrument. The following configuration is used for IMPROVE installations:

- EPROM Version 1057
- Clean air calibration intervals of 6 hours
- Operational mode #3 (2-minute integration every 5 minutes)
- Automatic span calibration upon power-up
- Automatic test upon power-up
- Default baud rate of 1200 bps
- Serial sign-on message (POST) enabled

### **4.1.2 Nephelometer Exterior and Cross-Sectional View Diagrams**

Figure 4-1 presents the major exterior components of the nephelometer. Figure 4-2 is a cross-sectional diagram of the nephelometer as it appears in the Optec manual. Table 4-1 details the pin-out allocation for the 9-pin nephelometer connector.

## **4.2 GAS CALIBRATION SYSTEM**

The gas calibration system is used to perform scheduled span and zero calibration checks of the nephelometer. These checks help ensure the nephelometer data are accurate. The system, illustrated in Figure 4-3, includes the following components:

- Span gas enclosure
- Span gas regulator
- Span gas rotameter with enclosure
- Span gas hoses
- Suva 134-a span gas tank

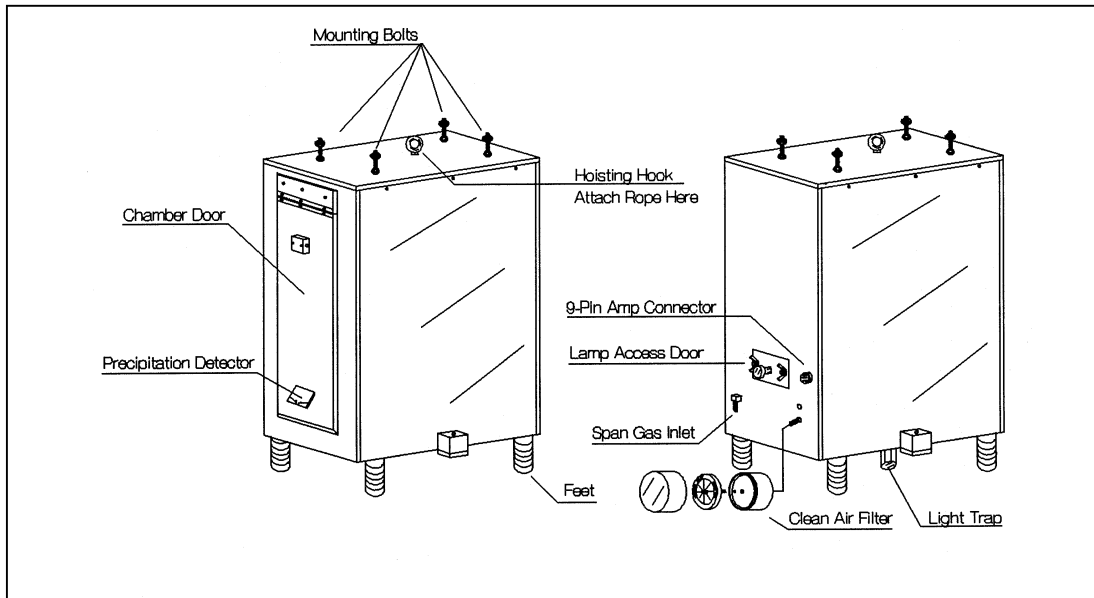

Figure 4-1. Optec NGN-2 Nephelometer Exterior Diagram.

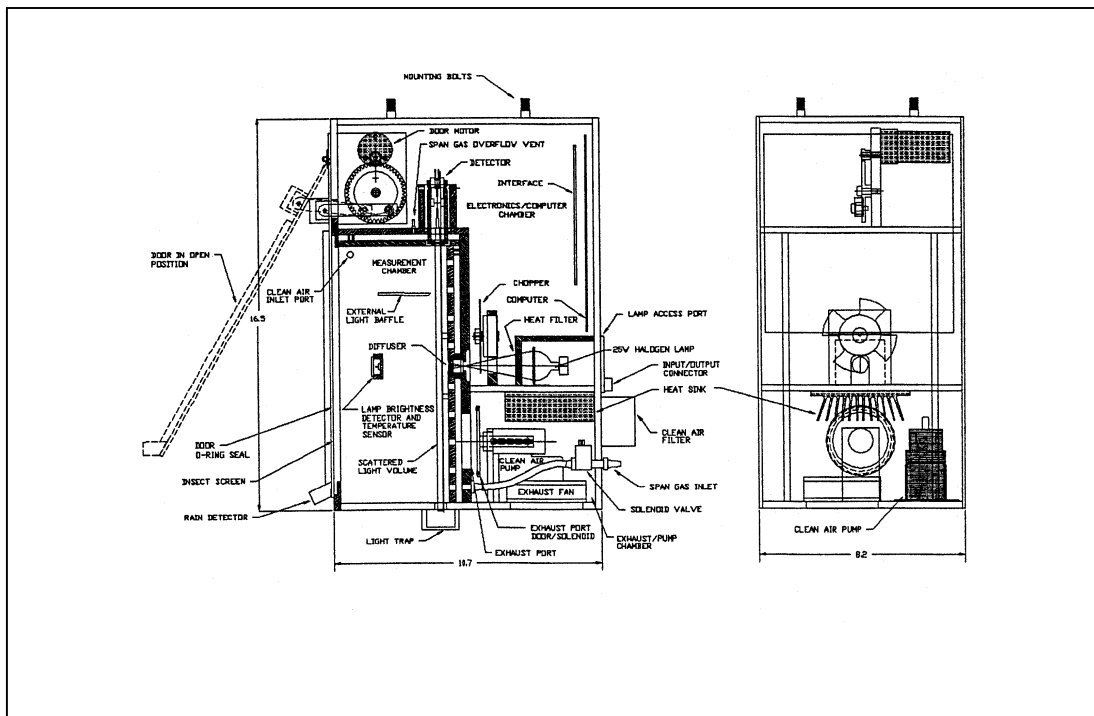

Figure 4-2. Optec NGN-2 Nephelometer Cross-Sectional View.



Table 4-1

Nephelometer 9-Pin Connector Description

NGN-2 Nephelometer Connector	
Pin #	Function
1	NEPH Power (13.8 VDC)
2	NEPH Power Return
3	Serial I/O, RS-232, RX
4	Serial I/O, RS-232, GND
5	Serial I/O, RS-232, TX
6	Analog-1 (scatter)
7	Analog-1 (common)
8	Analog-2 (status)
9	Analog-2 (common)

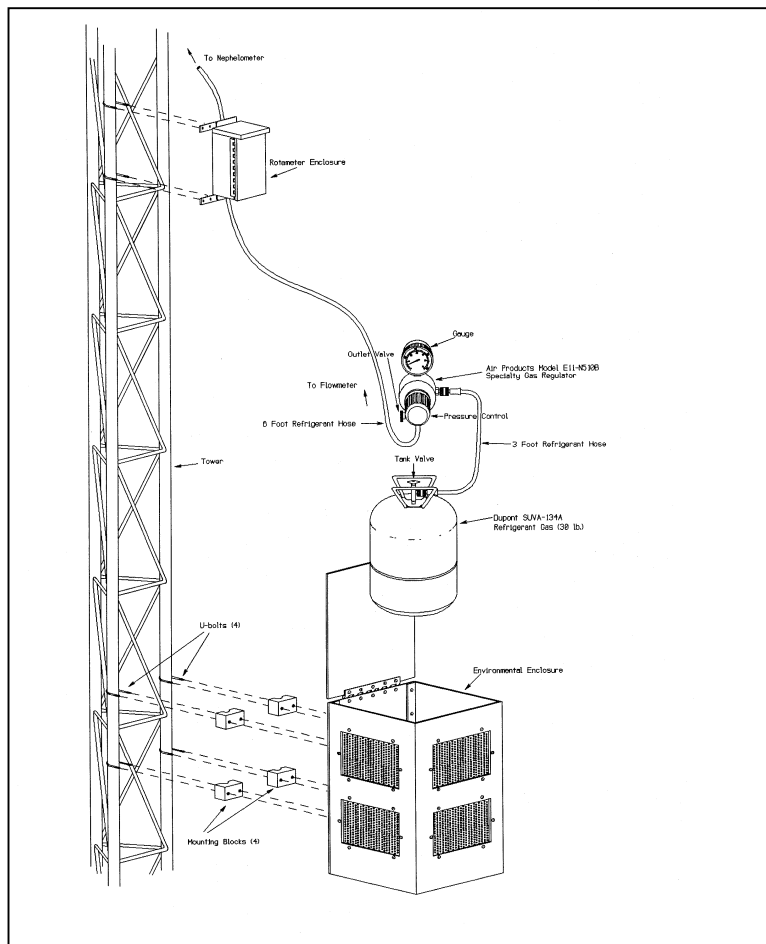

Figure 4-3. Span Gas Calibration System.

### 4.3 DATA LOGGING AND CONTROL SUBSYSTEM

The data logging and control subsystem supplies power to the nephelometer and allows for remote data collection. This section describes connectors, internal wiring, and sub-components in the data logging and control subsystem and contains the following subsections:

- 4.3.1 Major Sub-Components
- 4.3.2 Definitions of Wiring Abbreviations
- 4.3.3 Connector Panel Connector Locations
- 4.3.4 Connector Panel Wiring
- 4.3.5 Interface Circuit Board
- 4.3.6 Front Panel Wiring
- 4.3.7 AC Wiring
- 4.3.8 13.8 VDC Power Supply
- 4.3.9 Campbell 21X Datalogger Wiring
- 4.3.10 Nephelometer Power and Signal Cable

#### 4.3.1 Major Sub-Components

Table 4-2 presents the category, manufacturer, supplier, and model number of the major components in the data logging and control subsystem. Figure 4-4 shows the placement of the components within the enclosure.

Table 4-2

Major Components of the Data Logging and Control Subsystem

Data Logging and Control Subsystem Components			
Category	Manufacturer	Supplier	Model
Datalogger	Campbell Scientific	Campbell Scientific	21XL
Storage Module	Campbell Scientific	Campbell Scientific	SM192 or SM716
Primary Modem	Campbell Scientific	Campbell Scientific	DC110
Auxiliary Modem	Black Box	Black Box	Tote-A-Modem 1200 or Tote-A-Fax
13.8 VDC, 10 amp Power Supply for Nephelometer	SOLA	Newark	86-13-310
AC Line Monitor	Campbell Scientific	Campbell Scientific	ACL1
Surge Protector	Stabiline	Newark	PQI-1115
Interface Circuit Board with Blue Earth Micro-controller	ARS and Blue Earth Research	ARS and Blue Earth Research	2.1
Fan Thermostat	Therm-O-Disk	W. W. Grainger	4E116
12 VDC, 49 CFM Fan	Pabst	Newark	3412
LDC Front Panel Display	Jewel	Digikey	5900102141
AMP Connectors	AMP	Digikey	9-pin and 4-pin
Telephone Line Surge Protector	TrippLite	Digikey	TeleSpike Blok TSB
External UPS System	TrippLite	Digikey	BC-250

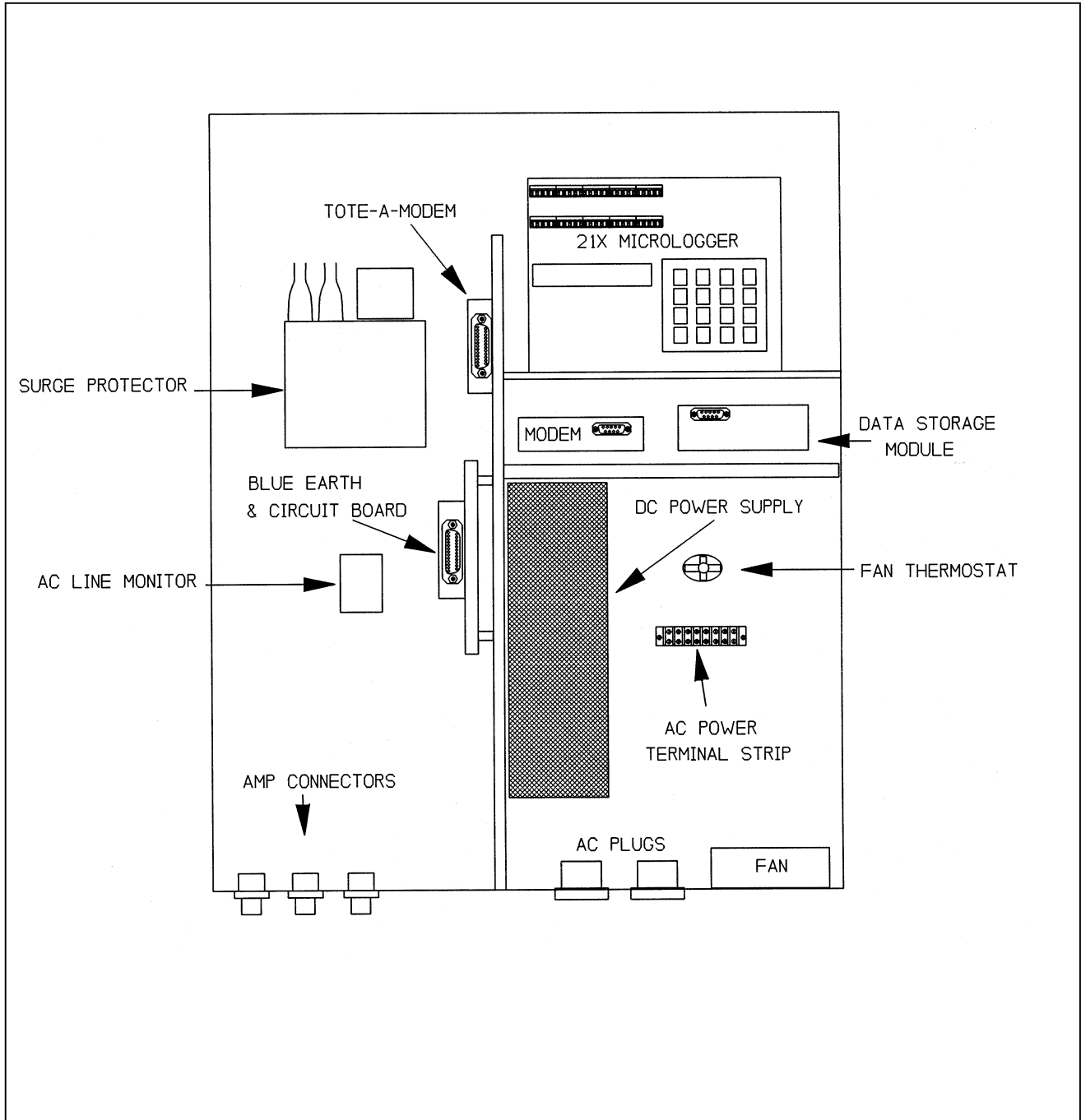

Figure 4-4. Data Logging and Control Subsystem Component Locations.

#### **4.3.2 Definitions of Wiring Abbreviations**

The following abbreviations are used to reference components and connectors:

21X	-	Campbell 21X micrologger
A1	-	Nephelometer analog channel 1
A2	-	Nephelometer analog channel 2
A,B,C, etc.	-	Connectors on interface circuit board
AC	-	AC line monitor
ACL	-	AC Line monitor
AMP	-	AMP-type connectors on bottom of enclosure
AT	-	Ambient Temperature
BE	-	Blue Earth microcontroller
CAO	-	Control Analog Output signal from 21X datalogger
CB	-	Interface Circuit Board (with Blue Earth microcontroller)
DB9	-	DB9-type connector for laptop computer on bottom of enclosure
DCP	-	Data Collection Platform
DTR	-	Data Terminal Ready signal from 21X datalogger to Blue Earth microcontroller
EXC	-	21X Excitation channel
FP	-	Front Panel
FPTS	-	Front panel terminal strip
GND	-	Ground
LCD	-	Liquid crystal display on front panel
N/C	-	Not Connected
NEPH	-	Nephelometer
PS	-	Power supply
RH	-	Relative Humidity
RX	-	RS-232 Receive signal
TM	-	Tote-a-modem
TX	-	RS-232 Transmit signal
TSP	-	Telephone Surge Protector

### **4.3.3 Connector Panel Connector Locations**

The connector panel on the data logging and control subsystem is on the underside of the enclosure. Figure 4-5 is a view of the connector panel from above and inside the enclosure. The connectors are standard male 4- and 9-pin AMP type.

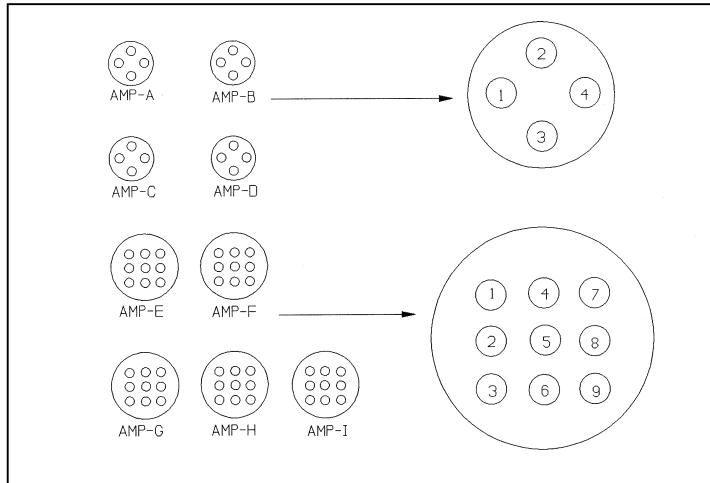

Figure 4-5. Data Logging and Control Subsystem Connector Panel.

### **4.3.4 Connector Panel Wiring**

Table 4-3 details the wiring related to connectors A,C,F,H and I. Connectors B,D,E,and G are not currently used.

### **4.3.5 Interface Circuit Board**

Figure 4-6 shows the layout of the interface circuit board. Tables 4-4 and 4-5 detail the wiring related to the Interface Circuit Board (CB).

### **4.3.6 Front Panel Wiring**

The enclosure front panel includes the following components as shown in Figure 4-7:

- Red neon AC power indicator
- Green incandescent 13.8 VDC power indicator
- Momentary 13.8 VDC power interrupt pushbutton switch
- LCD display
- AC and DC fuses
- Terminal strip connector block

Table 4-6 provides the manufacturer, supplier, and part number for the front panel components. Wiring for the front panel is diagrammed in Figure 4-7.

Table 4-3

Connector Panel Connector Wiring

<b>AMP Connector Pins and Wires</b>			
Pin #	Function	Color	To/From
<b>AMP-A Connector - External Nephelometer Computer Terminal (To/From CB - L)</b>			
1	Ground	Black/Red	L3, DB9-5
2	Neph RX	Blue/White	L1, DB9-2
3	Neph TX	Red/White	L2, DB9-3
4	N/C	-	-
<b>AMP-C Connector - Telephone (To/From CB-F)</b>			
1	N/C	-	-
2	Phone	Red	Through TSP to CB-F1
3	N/C	-	-
4	Phone	Green	Through TSP to CB-F3
<b>AMP-F Connector - Output to DCP (From CB-N)</b>			
1	Neph Analog A1-	Green/White	N2
2	Neph Analog A1+	Red	N3
3	Neph Analog A2-	Orange/Black	N4
4	Neph Analog A2+	White/Black	N5
5	N/C	-	-
6	N/C	-	-
7	CAO #2 GND	White/Red	21X CAO GND
8	CAO #2 Signal	Blue/Red	N1
9	N/C	-	-
<b>AMP-H Connector - Rotronics AT/RH Sensor and Fan (From CB-B)</b>			
1	Fan 12 VDC Supply	Orange/Red	B1
2	Fan 12 VDC Return	Red/Black	B2
3	N/C	-	-
4	AT Signal	Green/Black	B7
5	RH Signal	Green/Black/White	B6
6	N/C	-	-
7	8 to 30 VDC Sensor Power	Black/White	B3
8	Sensor Common	Red/Green	21X Excitation GND
9	N/C	-	-
* Orange/Green Tied Back - N/C			
<b>AMP - I Connector - NGN-2 Nephelometer (From CB-G and FP 12 VDC)</b>			
1	Neph Power (13.8 VDC)	Red (16 GA)	FP3
2	Neph Power Return	Black (16 GA)	FP4
3	RX	Blue/Black	G3
4	GND	Orange	G1
5	TX	Black	G2
6	A1+	Blue	G6
7	A1-	White/Red/Black	G7
8	A2+	Red/White/Black	G4
9	A2-	Black/White/Red	G5
Orange/Green From CP - B4 Tied Back - N/C			
Red/Green From CP - H8 tied to Orange/Green from 21X EXC GND #2			

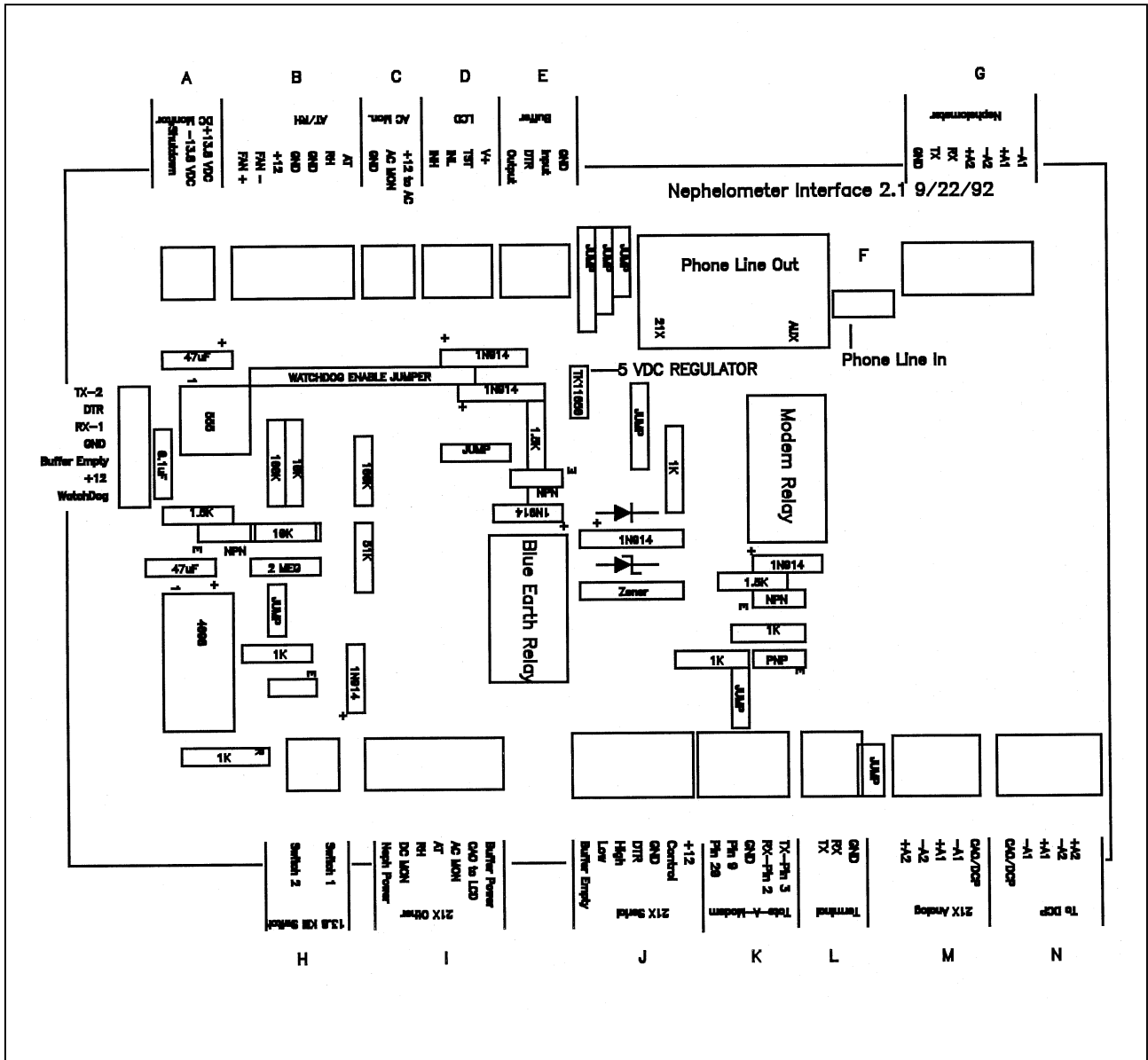

Figure 4-6. Interface Circuit Board Layout.

Table 4-4

Interface Circuit Board (CB) Connector Functions

<b>Interface Circuit Board Connector Functions</b>		
Connector	Function	Comments
A	DC Voltage Monitor	
B	AT/RH	
C	AC Line Monitor	
D	LCD Display	
E	Black Box Buffer	Not Used
F	Phone	
G	Nephelometer	
H	Reset 12 VDC Power	
I	21X Other	
J	21X Serial	
K	Tote - A - Modem	
L	Terminal	
M	21X Analog	
N	DCP	
P1	21X Modem	Phone Plug
P2	Tote - A - Modem	Phone Plug



Table 4-5

Interface Circuit Board Connector Wiring

<b>Interface Circuit Board Connector Wiring</b>			
Pin #	Function	Color	To/From
<b>A Connector - DC Voltage Monitor (From PS)</b>			
1	12 VDC Shut Off	Green	PS - 5
2	13.8 VDC-	Black	PS - 8
3	13.8 VDC+	Red	PS - 9
<b>B Connector - AT/RH Sensor (From CP - H)</b>			
1	Fan +	Orange/Red	AMP-H1
2	Fan -	Red/Black	AMP-H2
3	Sensor Power	Black/White	AMP-H7
4	N/C	Orange/Green	N/C
5	N/C	Red/Green	N/C
6	RH Signal	Green/White/Black	AMP-H5
7	AT Signal	Green/Black	AMP-H4
<b>C Connector - AC Line Monitor</b>			
1	AC Monitor Ground	Black	ACL-1
2	AC Monitor Signal	Orange	ACL-1
3	+12 VDC	Red	ACL-1
<b>D Connector - LCD Display</b>			
1	Input High	Green	LCD-7
2	N/C	-	-
3	N/C	-	-
4	+5 VDC	Red	LCD-1
<b>F Connector - Phone (To/From AMP-C)</b>			
1	Phone	Red	AMP-C2 through TSP
2	N/C	N/C	N/C
3	Phone	Green	AMP-C4 through TSP
<b>G Connector - Nephelometer (From AMP-H)</b>			
1	Ground	Orange	AMP-I4
2	TX	Black	AMP-I5
3	RX	Blue/Black	AMP-I3
4	A2+	Red/Black/White	AMP-I8
5	A2-	Black/White/Red	AMP-I9
6	A1+	Blue	AMP-I6
7	A1-	White/Red/Black	AMP-I7
<b>H Connector - 12 VDC PS Shut Down (To PS)</b>			
1	Switch	Black	FPTS-1
2	N/C	N/C	N/C
3	13.8 VDC	Red, Clear, or White	FPTS-2

-- continued --

Table 4-5 (Continued)

Interface Circuit Board Connector Wiring

<b>Interface Circuit Board Connector Wiring</b>			
Pin #	Function	Color	To/From
<b>I Connector - 21X Other (To/From 21X)</b>			
1	Neph Relay +	White	21X Control 1
	Neph Power Monitor	Red/Black	21X 5H
2	RH Signal	Blue/Red	21X 4L
3	AT Signal	Orange/Red	21X 4H
4	AC Line Monitor	White/Black	21X Pulse 1
5	CA01 to LCD	Red	21X CAO 1
6	BE Power Relay	Black/Red	21X Control 4
<b>J Connector - 21X Serial (To/From 21X)</b>			
1	Buffer Empty	White/Black/Red	21X 5L
2	Low	Green/White	21X 1L
3	High	Orange/Black	21X 1H
4	DTR	Orange	21X Control 3
5	GRD	Black	21X Power
6	Modem Control	Green	21X Control-2
7	+12	White/Red	21X PWR+12
<b>K Connector - Tote-A-Modem (To/From Auxiliary Modem)</b>			
1	Pin 20	Orange	TM Pin 20
2	Pin 8	Red	TM Pin 9
3	GND	Black	TM Pin 7
4	RX Pin 2	White	TM Pin 2
5	TX Pin 3	Green	TM Pin 3
<b>L Connector - Terminal (To/From AMP A)</b>			
1	Neph RX	Blue/White	AMP-A3, DB9-2
2	Neph TX	Red/White	AMP-A2, DB9-3
3	GND	Black/Red	AMP-A1, DB9-5
<b>M Connector - 21X Analog (To/From 21X)</b>			
1	Neph A2+	Blue/Black	21X 3H
2	Neph A2-	Green/Black	21X 3L
3	Neph A1+	Blue/White	21X 2H
4	Neph A1-	Green/Black/White	21X 2L
5	CA01 to DCP	Blue	21X CAO 2
<b>N Connector - DCP (To CP-F)</b>			
1	CA02 (DCP)	Blue/Red	AMP - F8
2	A1-	Green/White	AMP - F1
3	A1+	Red	AMP - F2
4	A2-	Orange/Black	AMP - F3
5	A2+	White/Black	AMP - F4
6	N/C	White/Red	N/C

Table 4-6

Major Components on the Data Logging and Control Subsystem Front Panel

Major Components on the Front Panel			
Category	Manufacturer	Supplier	Model
Green indicator	IDI	Digikey	1090D5-12V
Red indicator	IDI	Digikey	1030QD1
Fuse holder	Digikey	Digikey	F012-ND
Pushbutton switch	Augat	Newark	MSPF-101C
LDC Display	Jewel	Digikey	5900102141

Front panel wiring schematic.

Datalogger support system front panel.

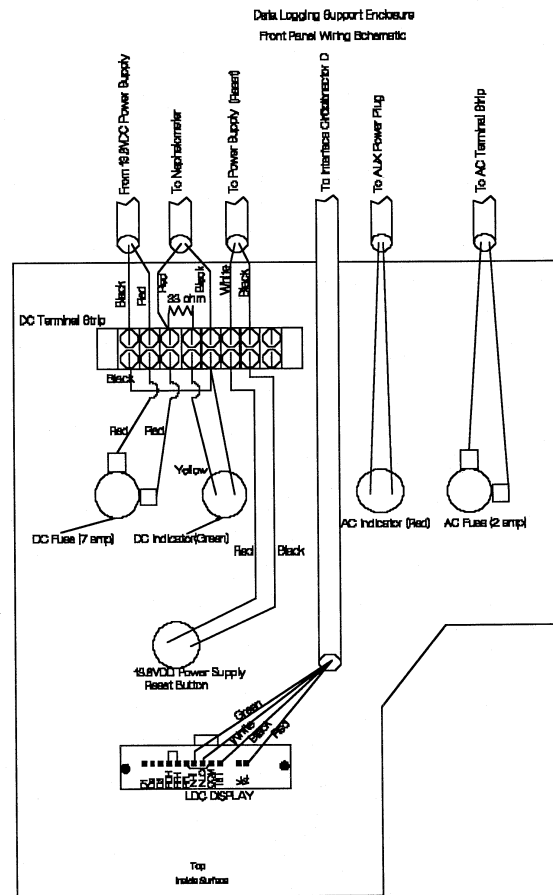
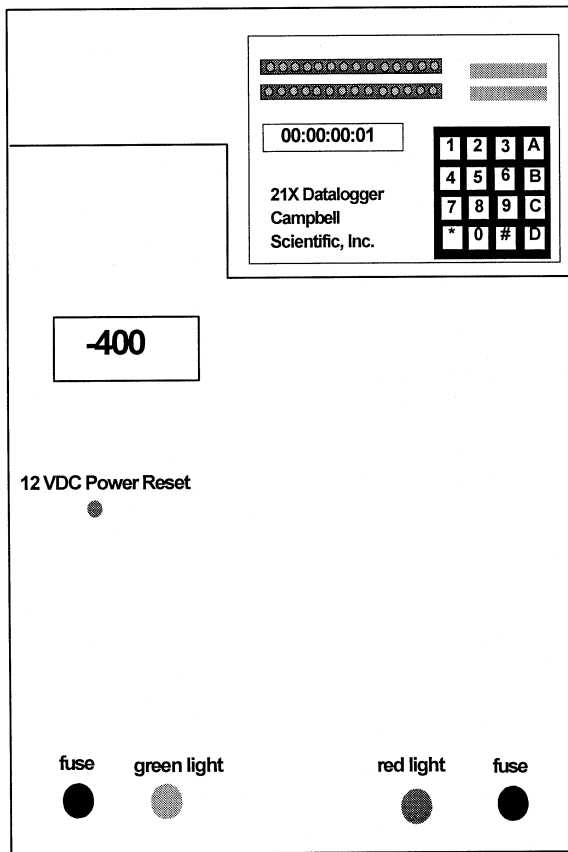

Figure 4-7. Datalogger Support System Front Panel.

### 4.3.7 AC Wiring

AC wiring for the enclosure includes the following components:

- Male twist-lock plug
- Female twist-lock socket
- AC surge protector
- Terminal strip
- Fuse

Table 4-7 provides the manufacturer, supplier, and part number for the AC wiring components. The AC wiring is diagrammed in Figure 4-8.

Table 4-7

Major Components of AC Wiring for Data Logging and Control Subsystem

Major Components of the Data Logging and Support System AC Wiring			
Category	Manufacturer	Supplier	Model
Male AC plug	GE	Loos Electric	GL0525
Female AC socket	GE	Loos Electric	GL0524
Fuse holder	Digikey	Digikey	F012-ND
Surge Protector	Stabiline	Newark	PQI-1115

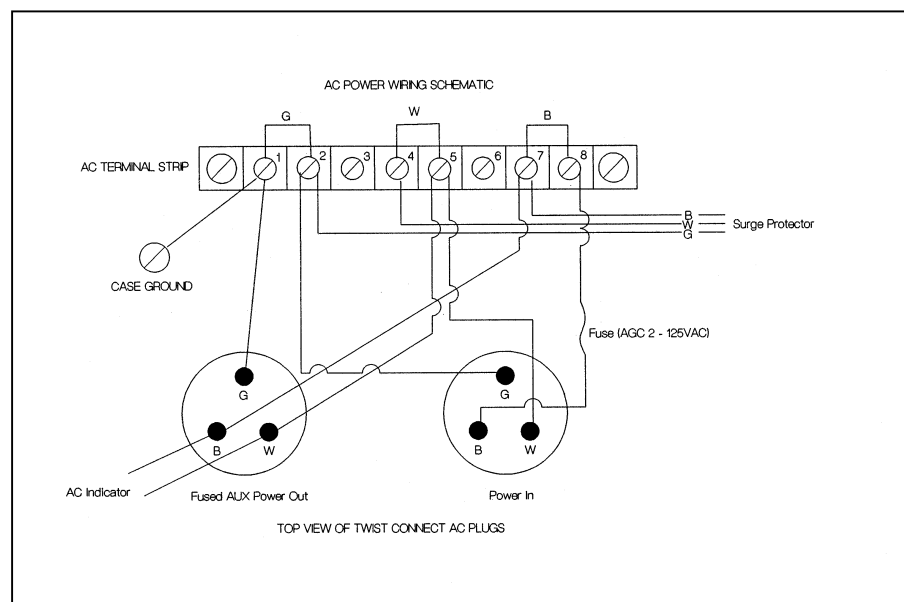

Figure 4-8. Data Logging and Control Subsystem AC Wiring Diagram.

#### 4.3.8 13.8 VDC Power Supply

The 13.8 VDC power supply provides power to the following components:

- Nephelometer
- AT/RH aspiration fan
- Data logging and control subsystem ventilation fan

Table 4-8 provides information on the wiring of the 13.8 VDC power supply terminal strip. The function of each screw terminal is indicated on the power supply.

Table 4-8

13.8 VDC Power Supply Terminal Strip Wiring

<b>Terminal Strip Wiring</b>			
Position #	Function	Color	To/From
1	AC Ground	Green -14 GA	AC Plug
2	AC Neutral	White (Black)-14 GA	AC Plug
3	AC Line	Black (Brown) -14 GA	AC Plug
4	Sig Ground	N/C	-
5	Shut Down	Green	CB - A1
6	Sense	N/C	-
7	Output-	Black	FP DC - Fuse
8	Output-	Black Black	CB - AZ (two)
9	Output+	Black Red	Therm Therm
10	Output+ Sense+	Red	CB - A3
11	Output+ Sense+	N/C	FP DC Fuse

Notes:

1. Positions 1, 2, and 3 plug from the AC power cord into the surge protector.
2. Positions 5, 8, and 9 plug from CB - through the hole in the center shelf support.
3. Positions 7 and 10 plug to the front panel fuse/indicator through the hole in the center shelf support.
4. Positions 8 and 9 plug into the thermostat/fan.

#### 4.3.9 Campbell 21X Datalogger Wiring

The Campbell 21X datalogger performs all measurements and controls the functions of the data logging and control subsystem. Figure 4-9 shows the locations of the terminals on the datalogger. Table 4-9 details the wiring connections to the datalogger.

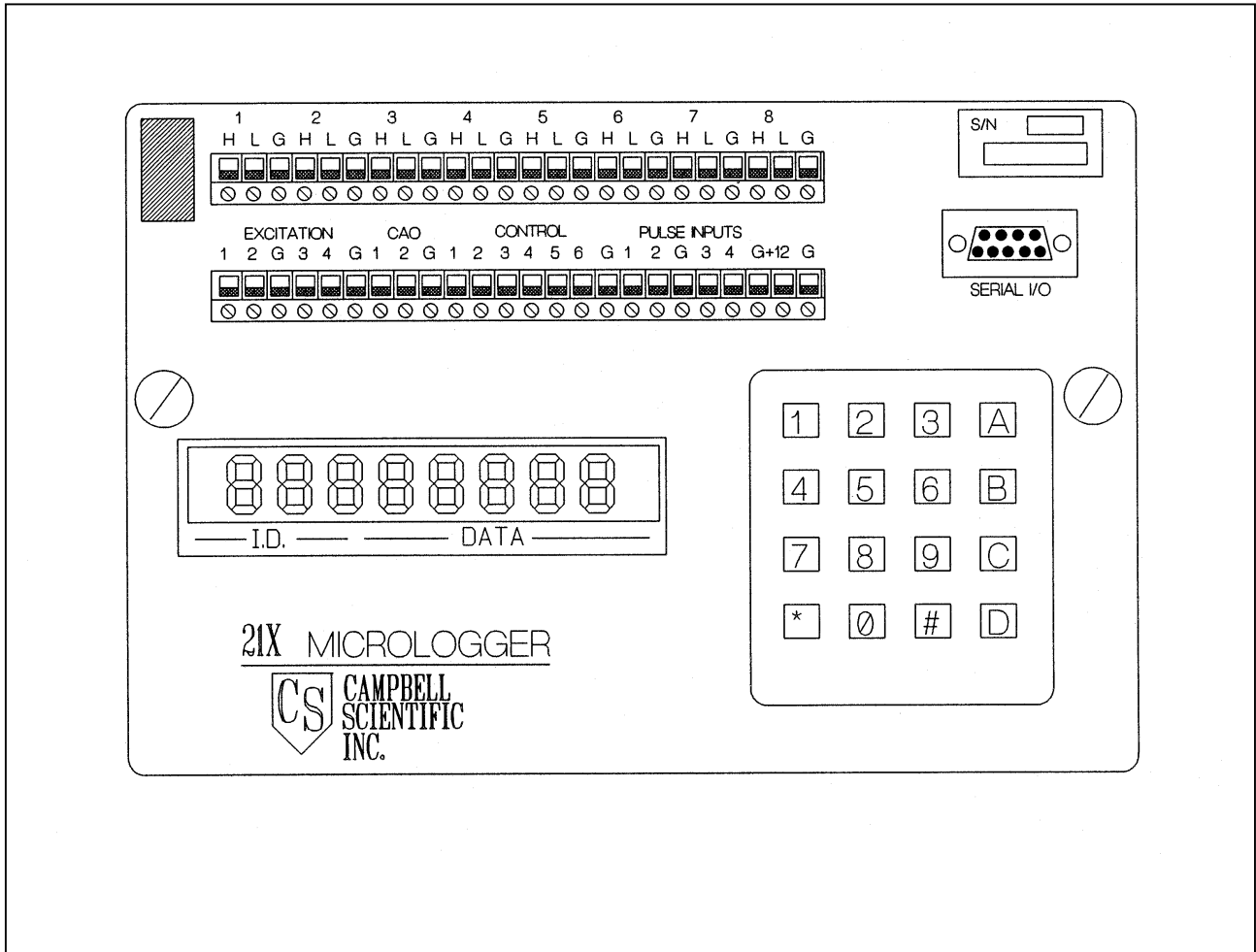

Figure 4-9. Campbell Scientific 21X Datalogger.

Table 4-9

Campbell 21X Datalogger Wiring Description

Sensor Connector - 9-Pin AMP Female		
Terminal	To/From	Color
1H	Serial High	Orange/Black
1L	Serial Low	Green/White
2H	Neph A1 +	Blue/White
2L	Neph A1 -	Green/Black/White
3H	Neph A2 +	Blue/Black
3L	Neph A2 -	Green/Black
4H	AT	Orange/Red
4L	RH	Blue/Red
5H	Neph Power Monitor	Red/Black
5L	Buffer Empty from Blue Earth	White/Black/Red
EXCITATION 1	N/C	
EXCITATION 2	N/C	
EXCITATION GND	AT/RH Common	Red/Black/White
EXCITATION 3	N/C	
EXCITATION 4	N/C	
EXCITATION GND	N/C	Orange/Green
CAO 1	LCD	Red
CAO 2	DCP Output	Blue
CAO GND	DCP Output Common	Red/White
CONTROL 1	Neph Relay Control	White
CONTROL 2	Modem Relay Control	Green
CONTROL 3	Serial DTR to Blue Earth	Orange
CONTROL 4	Blue Earth Power Relay	Black/Red
CONTROL 5	N/C	
CONTROL 6	N/C	
CONTROL GND	N/C	
PULSE INPUT 1	AC Line Monitor	White/Black
PULSE INPUT 2	N/C	
PULSE INPUT GND	N/C	
PULSE INPUT 3	N/C	
PULSE INPUT 4	N/C	
PULSE INPUT GND	N/C	
+12	Power to Interface Board	White/Red
GND	Power Return	Black

**4.3.10 Nephelometer Power and Signal Cable**

The nephelometer power and signal cable provides the following functions for the nephelometer:

- DC Power (13.8 VDC, 7 amps)
- RS-232 serial I/O (RX, TX, GND)

- Two analog output channels (A1, GND, A2, GND)

The cable assembly consists of the following components:

- 2-Conductor, 14-AWG cable for 13.8 VDC, 7 amp power
- 9-Conductor, 22 AWG cable for serial and analog data lines
- Two 9-Pin AMP connectors (one on each end of the cable)

Table 4-10 details the cable wiring pin and wire color assignments.

Table 4-10

Nephelometer Power and Signal Cable

Power and Signal Cable			
Pin #	Function	Color	Wire Type
1	13.8 VDC Power	Red	14 AWG
2	Power Return	Black	14
3	RX to Neph	White	22 AWG
4	Common	Black	22
5	TX from neph	Red	22
6	Analog 1 +	White/Black	22 AWG
7	Analog 1 -	Blue	22
8	Analog 2 +	Green	22
9	Analog 2 -	Orange	22

**4.4 SHIELDED AND ASPIRATED ROTRONICS AMBIENT TEMPERATURE AND RELATIVE HUMIDITY SENSOR**

The AT/RH sensor is used to provide weather parameter information and also to use as a quality assurance measure to compare with scattering measurements. Figure 4-10 shows an exploded view of the sensor and shield.

**4.4.1 Major Components**

The Rotronics AT/RH Sensor system includes the following components:

- Rotronics AT/RH Sensor (Model MP-100F)
- Force-aspirated shield
- Aspiration fan
- Cable assembly

Table 4-11 provides the manufacturer, supplier, and part number for the AT/RH system components.



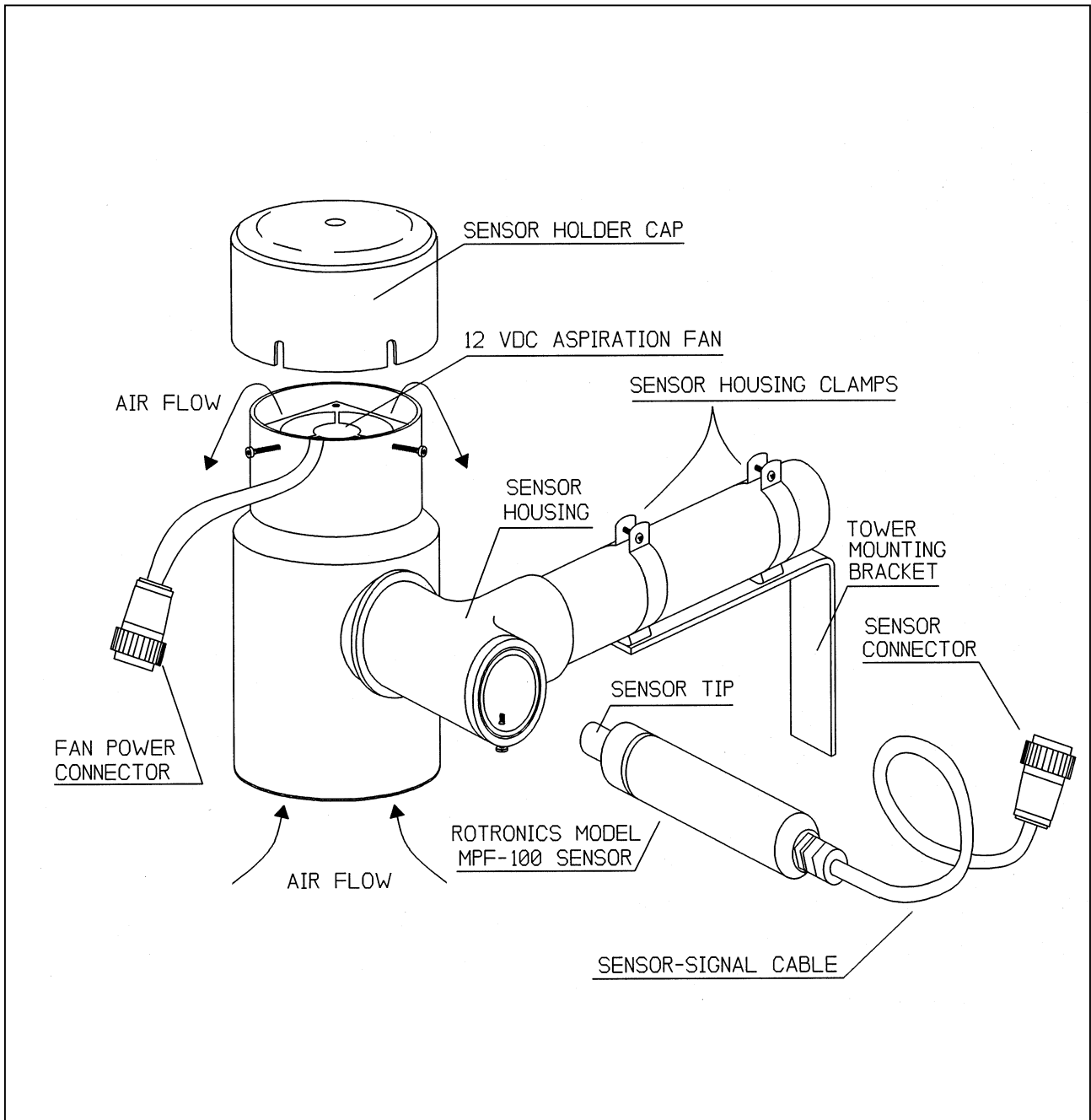

Figure 4-10. Rotronics AT/RH Sensor in Force-Aspirated Shield.

Table 4-11

Major Components of the Shielded and Aspirated Rotronics AT/RH Sensor System

<b>Major Components of the Rotronics AT/RH Sensor System</b>			
Category	Manufacturer	Supplier	Model
AT/RH Sensor	Rotronics	Rotronics	MP-100F
Shield (force-aspirated)	ARS Technologies	ARS Technologies	
Aspiration fan, 12 VDC,0.06A,0.72W	ComAir	Digikey	FS12H3

**4.4.2 Rotronics AT/RH Sensor and Aspiration Fan Connector and Cable**

Table 4-12 describes the Rotronics AT/RH sensor and aspiration fan connector and cable.

Table 4-12

Rotronics AT/RH Sensor and Aspiration Fan Connector and Cable Wiring

<b>Rotronics AT/RH Sensor and Fan Connectors and Wiring</b>		
Pin #	Function	Color
<b>Sensor Connector - 9-Pin AMP Female</b>		
1	Fan 12 VDC Supply	Red
2	Fan 12 VDC Return	Black
3	N/C	-
4	Air Temperature	White
5	Relative Humidity	Green
6	N/C	-
7	8 to 30 VDC Sensor Power	Red
8	Sensor Common	Black and Shield
9	N/C	-
<b>Fan Connector - 4-Pin AMP Female</b>		
1	Fan 12 VDC Supply	Red or White
2	Fan 12 VDC Return	Black
3	N/C	-
4	N/C	-

Notes:

1. Two cables run from the connector panel connector (H) to the AT/RH sensor holder. The fan power cable may be terminated at another connector (see Table 4-12 (4-Pin)).
2. Do not shorten the cable from the Rotronics AT/RH sensor - a change in calibration may occur.
3. The 12 VDC fan should be connected to draw air from the bottom of the sensor holder.
4. The white ceramic sensor cover protecting the Rotronics sensor elements should be centered within the holder column.
5. Fan wires have the + (red or white) towards the point of the female connector.

## **4.5 SUPPORT TOWER AND RELATED HARDWARE**

### **4.5.1 Major Components**

The support tower and related hardware include the following:

- A 10 or 14 foot Rohn tower
- Guy wires and related hardware
- A Rohn tower base

### **4.5.2 Tower-Related Components**

The tower and related components provide a suitable location for mounting the nephelometer (using the precipitation and solar radiation shield), data logging and control subsystem, and other components. Tower-related components include:

- A 10 foot or 14 foot (2 7-foot sections) Rohn tower and related components
- A Rohn tower base
- Guy wires
- Turnbuckles, links, and clamps
- Construction stakes with welded nuts

Figure 4-11 shows a typical tower setup including a tower and related hardware.

### **4.5.3 Wall Mount Option**

The nephelometer can be mounted to a wall using special wall-mount brackets. The wall-mount brackets support the precipitation and solar radiation shield that supports the nephelometer.

## **4.6 PRECIPITATION AND SOLAR RADIATION SHIELD**

The precipitation and solar radiation shield provide the following functions:

- A secure elevated location to mount the nephelometer
- Protection from direct precipitation
- Protection from direct solar radiation
- Pulleys for easy installation and removal of the nephelometer

Figure 4-12 details the nephelometer precipitation and solar radiation shield and its tower mounting configuration. Figure 4-13 details the precipitation hood.

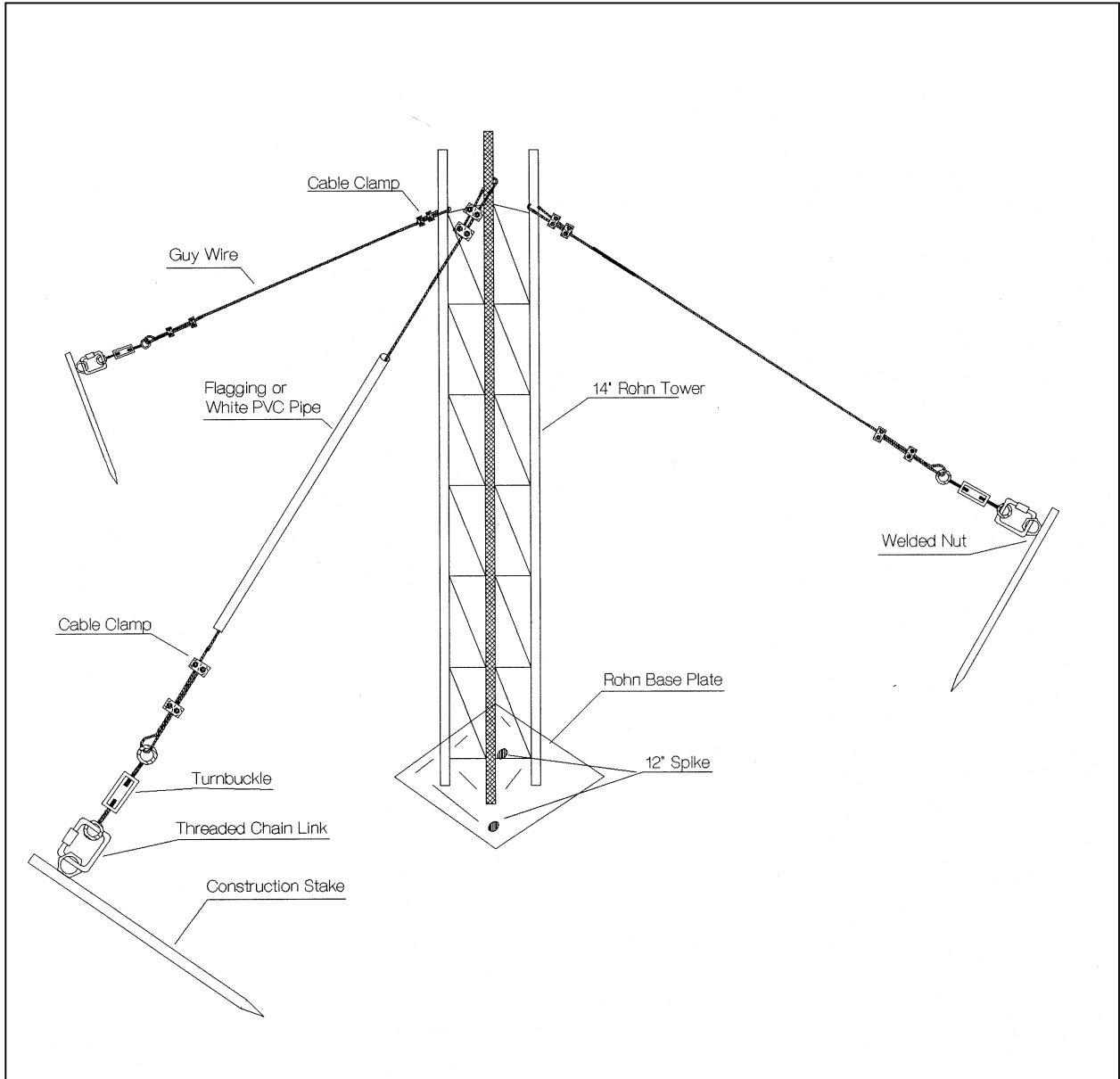

Figure 4-11. Nephelometer Support Tower and Related Hardware.

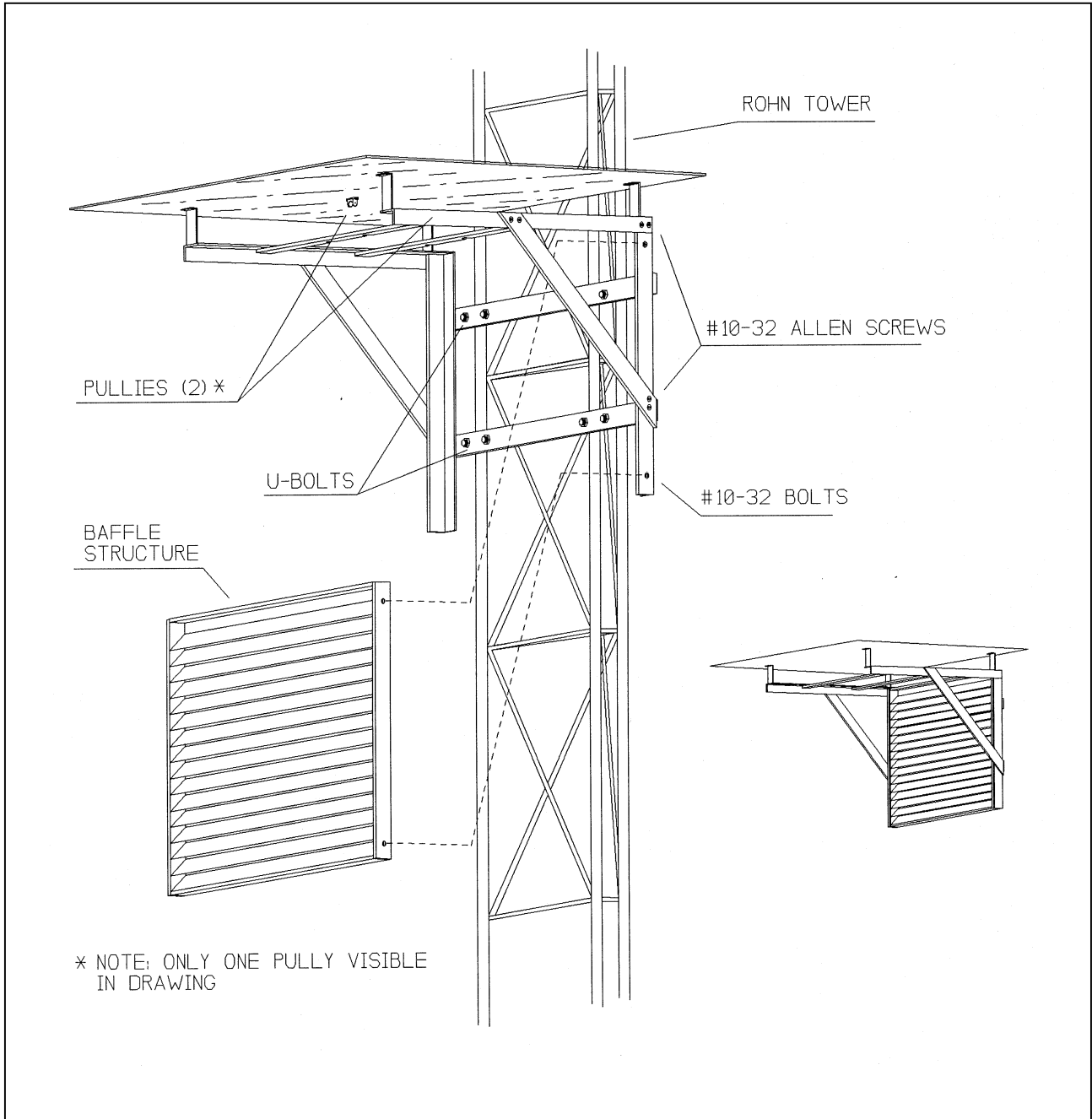

Figure 4-12. Precipitation and Solar Radiation Shield for Optec NGN-2 Nephelometer.

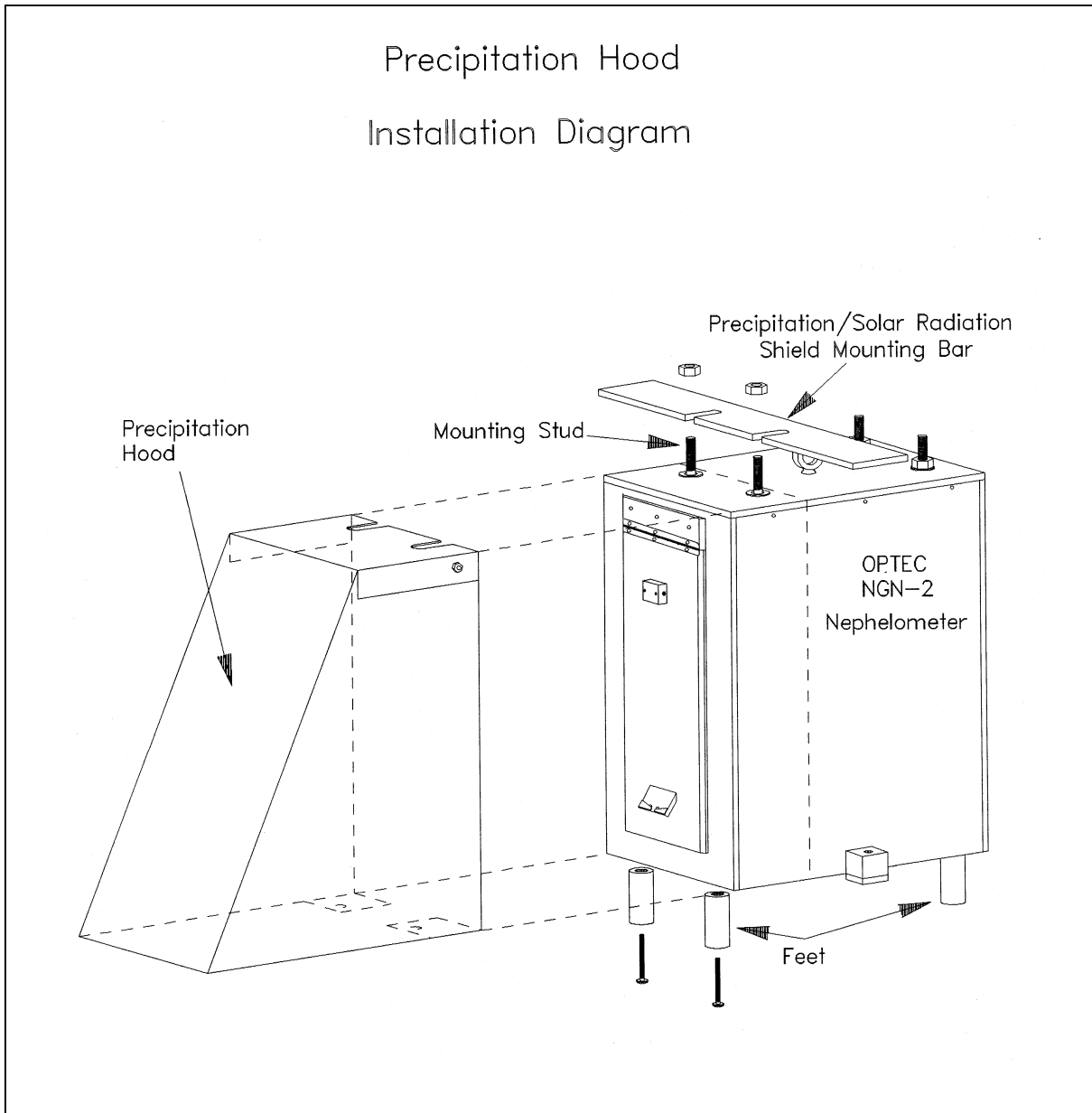

Figure 4-13. Precipitation Hood Installation Diagram.

## 5.0 REFERENCES

Optec, Inc. 1993, Model NGN-2 Open-Air Integrating Nephelometer, Technical Manual for Theory of Operation and Operating Procedures. Revision 4, November. Lowell, MI.

QUALITY ASSURANCE/QUALITY CONTROL DOCUMENTATION SERIES	
TITLE	<b>REPLACING AND SHIPPING NEPHELOMETER SYSTEM COMPONENTS</b>
TYPE	<b>TECHNICAL INSTRUCTION</b>
NUMBER	<b>4100-3375</b>
DATE	<b>JANUARY 1994</b>

AUTHORIZATIONS		
TITLE	NAME	SIGNATURE
ORIGINATOR	D. Scott Cismoski	
PROJECT MANAGER	James H. Wagner	
PROGRAM MANAGER	David L. Dietrich	
QA MANAGER	Gloria S. Mercer	
OTHER		

REVISION HISTORY			
REVISION NO.	CHANGE DESCRIPTION	DATE	AUTHORIZATIONS
0.1	Modifications to log sheet.	April 1995	
1.0	Diagram and minor text changes.	October 1996	

## TABLE OF CONTENTS

<b><u>Section</u></b>	<b><u>Page</u></b>
1.0 PURPOSE AND APPLICABILITY	1
2.0 RESPONSIBILITIES	1
2.1 Project Manager	1
2.2 Field Specialist	1
2.3 Data Coordinator	2
2.4 Site Operator	2
3.0 REQUIRED EQUIPMENT AND MATERIALS	3
4.0 METHODS	4
4.1 Nephelometer and Support Equipment Removal	4
4.1.1 Removing the Optec NGN-2 Nephelometer	4
4.1.2 Removing the Handar 540 DCP	6
4.1.3 Removing the Data Logging and Control Subsystem	10
4.1.4 Removing the Rotronics Air Temperature/ Relative Humidity Sensor	10
4.2 Nephelometer and Support Equipment Installation	12
4.2.1 Installing the Nephelometer	12
4.2.2 Installing the Data Logging and Control Subsystem	15
4.2.3 Installing the Handar 540 DCP	16
4.2.4 Installing the Rotronics Air Temperature/ Relative Humidity Sensor	18
4.3 Packing and Shipping	19

## LIST OF FIGURES

<b><u>Figure</u></b>	<b><u>Page</u></b>
4-1 Optec NGN-2 Nephelometer Exterior Diagram	5
4-2 NGN-2 Nephelometer/Meteorology Log Sheet	7
4-3 Handar 540 DCP Component Diagram	9
4-4 Data Logging and Control Subsystem Component Diagram	11
4-5 Rotronics Air Temperature/Relative Humidity Sensor Component Diagram	13



### LIST OF FIGURES (CONTINUED)

<b><u>Figure</u></b>	<b><u>Page</u></b>
4-6 AT/RH Sensor/DCP Cable Connection Diagram)	14
4-7 Data Logging and Control Subsystem Connector Panel Diagram (Viewed from inside the enclosure)	17

### LIST OF TABLES

<b><u>Table</u></b>	<b><u>Page</u></b>
4-1 Data Logging and Control Subsystem Connector Panel Description	17

## **1.0 PURPOSE AND APPLICABILITY**

This technical instruction (TI) describes procedures for removing, installing, and proper packing and shipping of nephelometer system components and support equipment at a field monitoring site.

This TI, as referenced in Standard Operating Procedure (SOP) 4100, *Nephelometer Maintenance (IMPROVE Protocol)*, specifically describes:

- Procedures for disconnecting power from instruments and support equipment.
- Procedures for removing instruments and support equipment from mounting hardware.
- Cables and other accessories to be packed and shipped with instruments and support equipment.
- Removal documentation requirements for instruments and support equipment.
- Procedures for installing replacement instruments and support equipment.
- Procedures for connecting power to instruments and support equipment.
- Procedures for verifying and documenting proper operation of replacement instruments and support equipment.
- Procedures for packing instruments and support equipment for shipment.
- Shipping methods required for each item.

## **2.0 RESPONSIBILITIES**

### **2.1 PROJECT MANAGER**

The project manager shall:

- Coordinate with the site operator, his/her supervisor, field specialist, and data coordinator concerning the schedule and requirements for specific nephelometer component replacement and shipment procedures.
- Oversee and review specific nephelometer component replacement and shipment procedure documentation completed by the site operator for accuracy and completeness.

### **2.2 FIELD SPECIALIST**

The field specialist shall:

- Coordinate with the site operator, his/her supervisor, project manager, and data coordinator concerning the schedule and requirements for specific nephelometer component replacement and shipment procedures.

- Train the site operator in all phases of specific nephelometer component replacement and shipment procedures necessary for on-site resolution of instrument problems.
- Provide technical support to the site operator via telephone to assure proper nephelometer component replacement and shipment procedures.
- Document all technical support provided to the site operator.
- Resolve problems reported by the site operator.

### **2.3 DATA COORDINATOR**

The data coordinator shall:

- Coordinate with the site operator, his/her supervisor, project manager, and field specialist concerning the schedule and requirements for specific nephelometer component replacement and shipment procedures.
- Identify possible instrument malfunction and contact the site operator to schedule a visit for nephelometer component replacement and shipment procedure implementation.
- Review documentation completed by the site operator for accuracy and completeness.
- Verify that scheduled visits are performed and notify the site operator if he/she fails to make a scheduled visit.
- Provide technical support to the site operator via telephone to assure proper nephelometer component replacement and shipment procedures.
- Document all technical support provided to the site operator.
- Review and file all site documentation.
- Resolve problems reported by the site operator.
- Send supplies, tools, and replacement instrumentation necessary for instrument problem resolution to the site operator.
- Make the necessary arrangements for pick up and return shipment of malfunctioning nephelometer components.
- Enter all correspondence with the site operators and the results of all performed procedures into site-specific timelines.

### **2.4 SITE OPERATOR**

The site operator shall:

- Coordinate with his/her supervisor, project manager, field specialist, and data coordinator concerning the schedule and requirements for specific nephelometer component replacement and shipment procedures.

- Perform all field-related procedures described in this TI.
- Thoroughly document all nephelometer component replacement and shipment actions on the NGN-2 Nephelometer/Meteorology Log Sheet and mail the log sheet to the data coordinator.
- Report any noted inconsistencies immediately to the data coordinator or field specialist.

### **3.0 REQUIRED EQUIPMENT AND MATERIALS**

The following equipment is generally required for nephelometer component replacement and shipment:

- Keys for shelters and padlocks
- 30' nephelometer hoisting rope with hook
- NGN-2 Nephelometer/Meteorology Log Sheet
- Pen or pencil
- Site Operator's Manual for Nephelometer Systems
- Small, medium, and large flat-blade screwdriver
- Medium adjustable wrench
- Electrical tape
- Pliers
- Blower (photographic) brush
- Cleaning cloth
- Nephelometer shipping case or box
- Support equipment shipping cases or boxes
- Packing material
- ARS shipping labels
- Packing tape

## 4.0 METHODS

This section includes three (3) major subsections:

- 4.1 Nephelometer and Support Equipment Removal
- 4.2 Nephelometer and Support Equipment Installation
- 4.3 Packing and Shipping

### 4.1 NEPHELOMETER AND SUPPORT EQUIPMENT REMOVAL

The following subsections describe the procedures for disabling and removing the nephelometer and support equipment. The subsections include:

- Removing the Optec NGN-2 nephelometer
- Removing the Handar 540 DCP
- Removing the data logging and control subsystem
- Removing the Rotronics air temperature/relative humidity sensor

#### 4.1.1 Removing the Optec NGN-2 Nephelometer

Take the appropriate shipping case or box to the site when removing the nephelometer so the instrument will be protected during transit. See Section 4.3 for packing and shipping instructions. Removing the instrument is much easier with two people, so bring help to the site if possible.

#### DISCONNECT

Reset the power to the nephelometer so the nephelometer door will close. Shipping the instrument with the door closed is preferred. If all power systems have failed this may not be possible.

Disconnect the signal/power cable from the back of the nephelometer. Tape the end of the cable connector with electrical tape and allow the connector to hang down to prevent moisture from entering.

Disconnect the span gas hose from the back of the nephelometer.

#### REMOVE

Attach the nephelometer hoist rope hook to the circular hook on top of the nephelometer. Feed the rope through the two (2) pulleys on the underside of the precipitation/solar radiation shield and extend the rope to ground level. Refer to Figure 4-1, Optec NGN-2 Nephelometer Exterior Diagram, for location of the hoist rope hook.

Take up all slack in the rope and TIE THE ROPE SECURELY TO THE TOWER NEAR THE GROUND.

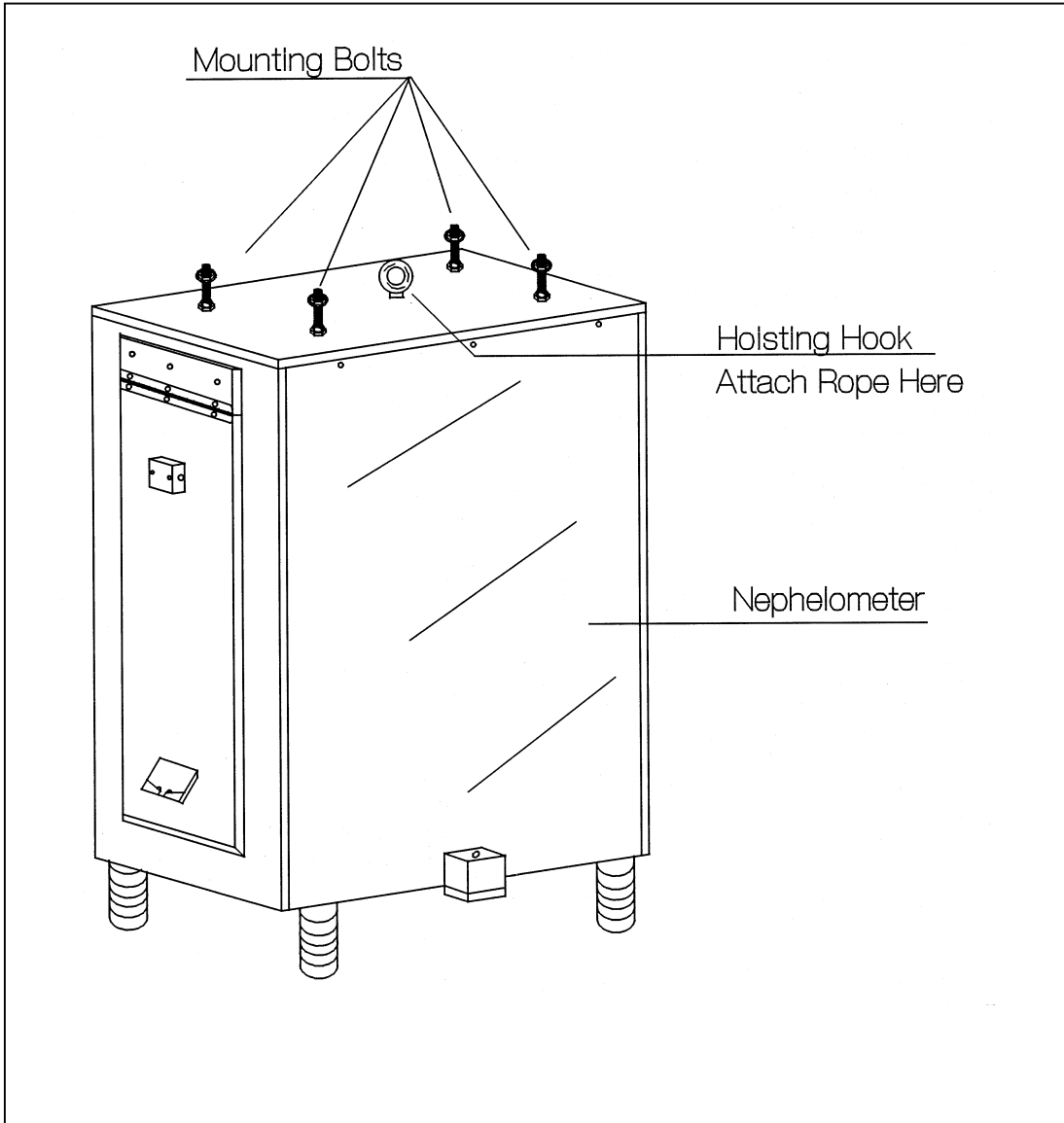

Figure 4-1. Optec NGN-2 Nephelometer Exterior Diagram.

Loosen (but do not remove) the four (4) nuts holding the nephelometer to the precipitation/solar radiation shield and slide the nephelometer out of the mounting slots. Be certain that the rope will hold the nephelometer.

Use the rope to lower the nephelometer carefully to the ground.

Carefully pack the nephelometer in the shipping case or box. Be sure to use sufficient packing material to protect the nephelometer during transit.

#### DOCUMENT

Document removal of the instrument on the operator log sheet. Figure 4-2 is an example NGN-2 Nephelometer/Meteorology Log Sheet.

### **4.1.2 Removing the Handar 540 DCP**

Take the appropriate shipping case or box to the site when removing the DCP so the instrument will be protected during transit. See Section 4.3 for packing and shipping instructions. Figure 4-3 depicts the DCP datalogger component diagram and details the location of the switches and connectors discussed in this section.

**IMPORTANT:** Before disconnecting the DCP antenna cable, some internal switch settings must be changed to inhibit transmissions. Failure to do so will damage the DCP.

Follow the procedures below when removing the DCP:

#### RESET

Loosen the clasps and open the hinged door of the DCP. Locate the six (6) red, square, dial switches located on the circuit board on the inside of the DCP door. Refer to close-up of dial switches in Figure 4-3.

Using a small flat-blade screwdriver, reset the switches under "CHAN 1" to **9, 0, 0**. The switch immediately below the "100" on the circuit board should be set to **9**. The switches immediately below the "10" and the "1" on the circuit board should be set to **0**.

Close the DCP door and tighten the clasps.

#### DISCONNECT

Before disconnecting the connectors on the side of the DCP, note their locations and mark if necessary. Draw a wiring diagram if it will be helpful. Refer to Figure 4-3.

Disconnect all cables from the DCP input panel and tape the ends of the cables with electrical tape. Allow the connectors to hang down to prevent moisture from entering.

#### REMOVE

Remove the DCP by loosening the tower mounting bolts. Pack the unit for shipping in the supplied box.

#### DOCUMENT

Document the removal of the DCP on the log sheet.



Location \_\_\_\_\_

**NGN-2 NEPHELOMETER/METEOROLOGY LOG SHEET**

Date \_\_\_\_\_ Local Time \_\_\_\_\_ : \_\_\_\_\_ ( ) Operator(s) \_\_\_\_\_  
Weather Conditions (Temperature, Wind, Precipitation) \_\_\_\_\_  
Visibility Conditions \_\_\_\_\_

**Support Tower, Guy Wires and/or Other Structural Components**

1. Physical condition: \_\_\_\_\_

**AC and DC Power Indicator Lamps**

- 1. Status of the red AC indicator lamp:      **ON**   **OFF**   If off, replace AC fuse (2-amp) and note time \_\_\_\_\_ : \_\_\_\_\_ : \_\_\_\_\_
- 2. Status of the green DC indicator lamp:   **ON**   **OFF**   If off, replace DC fuse (7-amp) and note time \_\_\_\_\_ : \_\_\_\_\_ : \_\_\_\_\_

**Datalogger**

- 1. General Physical Condition: \_\_\_\_\_
- 2. The support system front panel display will show a **NEGATIVE** number to indicate certain nephelometer operating problems. If the display is approximately one of the following values, perform the action listed and note the time.

Display	Problem	Action	Time (HH : MM)
-400	Lamp burned out	Replace nephelometer lamp, then push red reset button on the support front panel for 5 seconds	_____ : _____
-500	Rain event	None required	_____ : _____
-600	Bad chopper motor frequency	Push red reset button on support system front panel	_____ : _____
-900	Serial data interface failure	Call ARS	_____ : _____

- 3. Record the following parameters from the datalogger:

Key Sequence	Display	Measurement Parameter
*64A	04: _____	Nephelometer status code: 1 = good read (ambient), 2 = clean air (zero calibration), 3 = span calibration, 4 = lamp out, 5 = rain, 6 = chopper
A	05: _____	Nephelometer ambient reading (Reading must be > than last zero (*612A))
*68A	08: _____	Nephelometer power supply (VDC) <b>Call ARS if power is less than</b>
A	09: _____	Campbell 21X internal battery voltage (VDC) <b>12 volts or greater than 15 volts.</b>
*611A	11: _____	$b_{scat}$ ( $km^{-1}$ ) or problem code. Does this match front panel display? (Call ARS if it does not)
*617A	17: _____	Nephelometer lamp intensity (counts) <b>Call ARS if counts are below 1500</b>

- 4. Check the datalogger date and time: **Note: The 21X datalogger is always kept on Standard Time.**

- a. Synchronize your watch with NBS (WWW) time. (303-499-7111)
- b. Record time on your watch (HH:MM:SS) \_\_\_\_\_ : \_\_\_\_\_ : \_\_\_\_\_
- c. Record datalogger date and time:

Key Sequence	Current Display
*5	_____ : _____ : _____ Current time (HH:MM:SS)
A	05: _____ Year
A	05: _____ Julian date

- d. IF DATE IS INCORRECT OR TIME DIFFERS BY MORE THAN 1 MINUTE FROM NBS TIME, CALL ARS

- e. Return datalogger to run mode:

Key Sequence	Display
*0	LOG12

**Nephelometer**

- 1. General physical condition : \_\_\_\_\_
- 2. Condition of the inlet screen and door gasket: \_\_\_\_\_  
(If the screen or gasket is obstructed, call ARS for instructions)
- 3. Sample fan:      **ON**      **OFF**      Condition of the sample fan and fan guard: \_\_\_\_\_
- 4. Clean air pump:   **ON**      **OFF**
- 5. Nephelometer door:   **OPEN**      **CLOSED**
- 6. Lamp cycling at the 2-minute ON, 3-minute OFF schedule?   **YES**      **NO**
- 7. Inspect clean air filter:   **YES**   **NO**   Replaced   **YES**   **NO**   Condition of old clean air filter: \_\_\_\_\_
- 8. Remove and inspect light trap:   **YES**   **NO**   Condition of light trap: \_\_\_\_\_

Figure 4-2. NGN-2 Nephelometer/Meteorology Log Sheet.



9. Calibration - Before beginning calibration, check the \*612 and \*613 positions on the 21X datalogger (see #11 below).  
    \*612A Display \_\_\_\_\_ \*613A Display \_\_\_\_\_
- Turn flowmeter off (clockwise rotation).
  - Connect the calibration gas hose to the regulator outlet.
  - Turn on the span gas tank valve (1/2 turn).
  - Press and hold the red reset button on the support system front panel for 5 seconds.  
Record the time the red reset button was pressed: \_\_\_\_\_:\_\_\_\_\_:\_\_\_\_\_
  - The nephelometer will initiate a Power-On Self Test (POST). Document that the POST functions operate correctly:
    - Door close and open: YES NO
    - Lamp and chopper on: YES NO
    - Fan on and off: YES NO
    - Solenoid on and off: YES NO
    - Clean air pump on and off: YES NO
    - Valve on and off: YES NO
    - Fan on; solenoid turns on: YES NO
    - One-minute ambient reading: YES NO
    - Door closes: YES NO
  - Adjust the span gas regulator pressure control valve to 2-4 psi. Record the pressure: \_\_\_\_\_
  - Slowly** adjust the flowmeter to approximately 20 mm on the Cole Parmer flowmeter. (Make sure the door has been closed for at least 30 seconds before adjusting the flowmeter). Record the flow value: \_\_\_\_\_ mm
  - Following the POST, the system will perform a 20-minute span calibration check, followed by a 1-minute span gas purge, followed by a 15-minute clean air zero calibration check.
  - When the nephelometer door opens (36 minutes after starting the span calibration check) the span and zero calibration checks are complete.
10. TURN THE SPAN GAS TANK VALVE FULLY OFF. Disconnect the calibration gas hose at the regulator outlet to bleed excess gas from the hose, and turn the flowmeter off (clockwise rotation).
11. Record the results of the zero and span calibration checks from the datalogger:
- | <u>Key Sequence</u> | <u>Display</u> | <u>Measurement Parameter</u>   |
|---------------------|----------------|--|
| *612A               | 12: _____      | Last zero calibration check (counts)   |
| A                   | **13: _____    | Last span calibration check (counts) **This number should be slightly different than the *613A reading taken before the calibration check. |

**Meteorology** (Air Temperature/Relative Humidity Sensor; Wind Speed and Wind Direction Sensors)

- General physical condition: \_\_\_\_\_
  - Wind sensors unobstructed and free moving: YES NO Comment if NO: \_\_\_\_\_
  - AT/RH aspiration fan operating: YES NO Condition of the AT/RH screen: \_\_\_\_\_
  - Record the following meteorological parameters from the datalogger: (Note - not all sites have wind speed and wind direction sensors)
- | <u>Key Sequence</u> | <u>Display</u> | <u>Measurement Parameter</u>  |
|---------------------|----------------|-------------------------------|
| *61A                | 01: _____      | Ambient temperature (C)       |
| A                   | 02: _____      | Ambient relative humidity (%) |
| *652A               | 52: _____      | Wind speed (mph)              |
| A                   | 53: _____      | Wind direction (degrees true) |
5. Datalogger values reasonable for current conditions: YES NO Comment: \_\_\_\_\_

**Support System**

- If required, exchange the Campbell SM716 or SM192 storage module with a new one. Record the following:

	<u>Old module</u>	<u>New module</u>
Model (SM192, SM716)	_____	_____
Serial number	_____	_____
Time removed/installed (HH:MM)	_____:_____	_____:_____
- Complete removal information on the old module's Quality Assurance Card and installation information on the new card.
- Check all connectors.
- Call ARS immediately if you have any problems or questions.

**General Comments and Supplies Needed**

\_\_\_\_\_

\_\_\_\_\_

\_\_\_\_\_

FAX and mail the original white 2-page log sheet to:  
Leave yellow copy on-site

Air Resource Specialists, Inc.  
Attn: Data Coordinator  
1901 Sharp Point Drive, Suite E  
Fort Collins, CO 80525

Phone: 970-484-7941  
Fax: 970-484-3423

Figure 4-2. (Continued). NGN-2 Nephelometer/Meteorology Log Sheet.

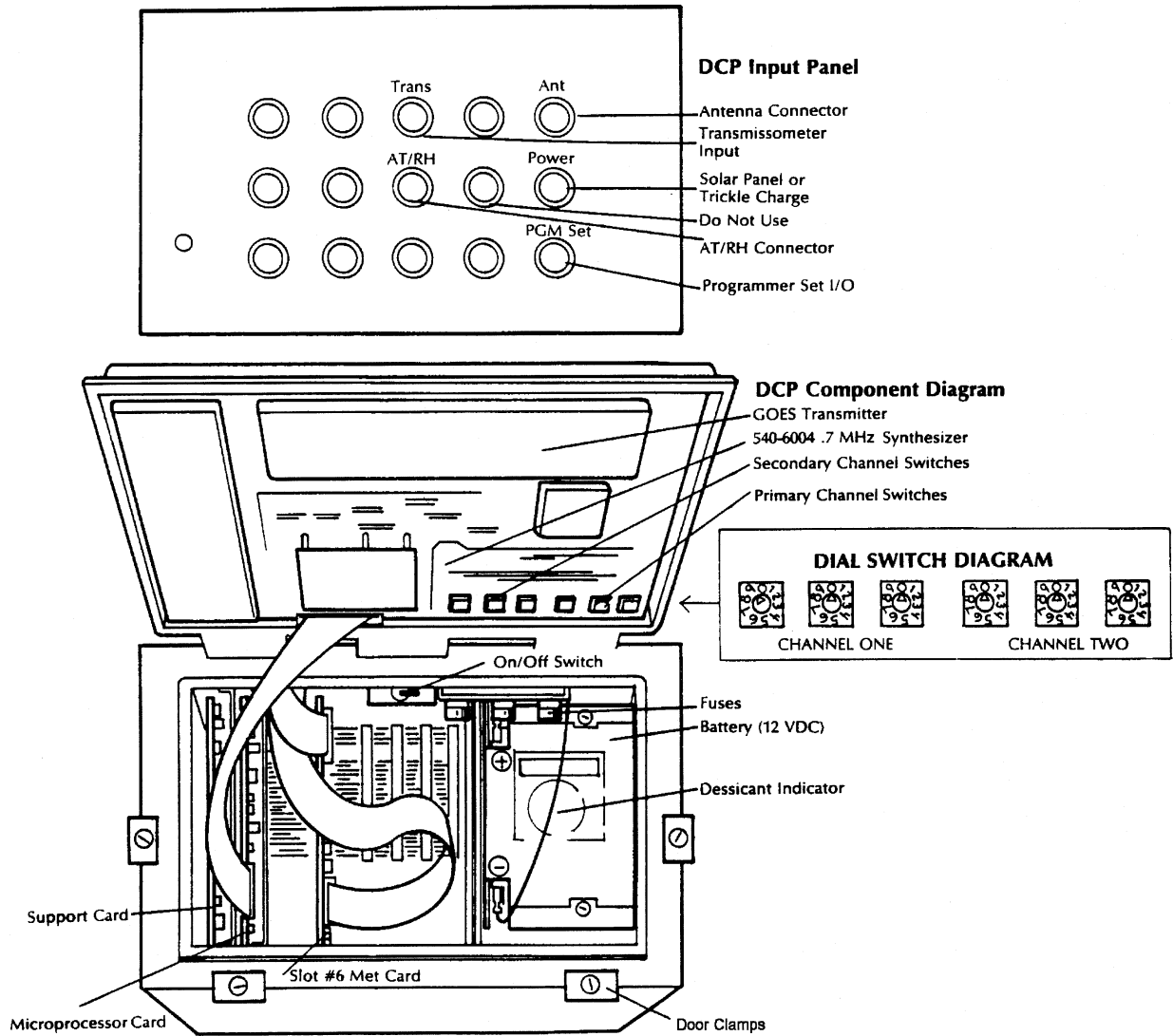

Side View DCP Input Panel

**IMPORTANT--**DCP panels may differ from the above unit.

Figure 4-3. Handar 540 DCP Component Diagram.

### **4.1.3 Removing The Data Logging and Control Subsystem**

Take the appropriate case or box to the site when removing the data logging and control subsystem so that the instrument will be protected during transit. See Section 4.3 for packing and shipping instructions. Figure 4-4 is a diagram of the data logging and control subsystem. Follow the procedures below for removal and packing of the enclosure:

**DISCONNECT** Disconnect 115 VAC power to the enclosure at the main AC supply (e.g., breaker box or wall plug).

Disconnect all cables from the bottom outside of the enclosure.

Tape the end of each cable connector with electrical tape. Allow the connectors to hang down to prevent moisture from entering.

Open the enclosure and place packing material (bubble-wrap) around the following items to assure they will be secure during transit:

- Campbell datalogger
- Campbell storage module
- Campbell modem
- AC surge protector
- Other loose components

Verify that all components in the enclosure are secure for shipping.

**REMOVE** Loosen and remove the four (4) bolts securing the enclosure to the tower, or remove any other mounting screws securing the enclosure.

Carefully pack the enclosure in the shipping case or box using packing material to protect the enclosure during transit.

**DOCUMENT** Document the removal of the enclosure on the operator log sheet.

### **4.1.4 Removing the Rotronics Air Temperature/Relative Humidity Sensor**

Follow the procedures below when removing the Rotronics air temperature/relative humidity sensor:

**DISCONNECT** The AT/RH sensor is mounted in a fan-aspirated shield. Remove only the sensor; do not remove the shield unless requested by ARS.

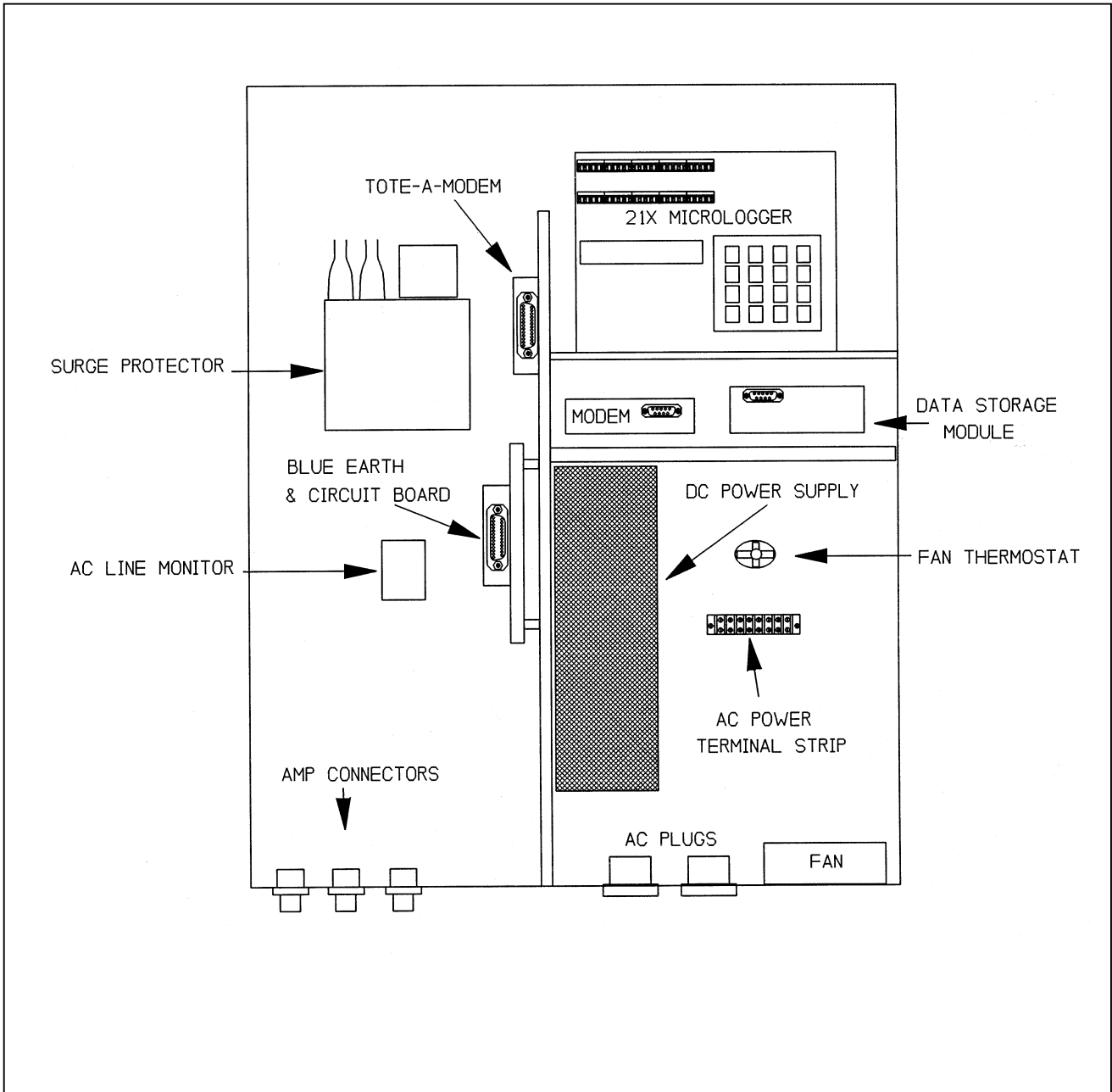

Figure 4-4. Data Logging and Control Subsystem Component Diagram.

Disconnect the air temperature/relative humidity sensor cable at the connection below the sensor (signal cable). See Figure 4-5, Rotronics Air Temperature/Relative Humidity Sensor Component Diagram, and Figure 4-6, AT/RH Sensor/DCP Cable Connection Diagram).

Tape the end of the cable connector with electrical tape. Allow the connector to hang down to prevent moisture from entering.

REMOVE

Loosen the sensor-securing bolt on the AT/RH shield and slide the sensor out of the shield.

Pack the sensor and shield (if requested) in the case or box for shipping.

DOCUMENT

Document the removal of this sensor on the operator log sheet.

## 4.2 NEPHELOMETER AND SUPPORT EQUIPMENT INSTALLATION

Replacement nephelometer components will be shipped directly to the site operator by ARS. Upon receipt of the shipment, the site operator should follow the component-specific procedures listed below. Additional installation diagrams can be found in TI 4070-3000, *Installation of Optec NGN-2 Nephelometer Systems (IMPROVE Protocol)*, and TI 4100-3350, *NGN-2 Nephelometer Monitoring Systems Diagrams and Component Descriptions*.

### 4.2.1 Installing the Nephelometer

Follow the procedures below when installing the nephelometer:

INSTALL

Leave the nephelometer in the shipping case or box until at the site.

Inspect the shipping case for signs of damage upon receiving the nephelometer. Carefully unpack the nephelometer and remove it from the shipping case or box.

Feed the hoist rope through the two (2) pulleys on the underside of the precipitation/solar radiation shield (see Figure 4-1), and attach the nephelometer hoist rope hook to the circular hook on top of the nephelometer (see Figure 4-1).

Loosen the four (4) mounting nuts on the top of the nephelometer.

Use the rope to raise the nephelometer to the precipitation/solar radiation shield.

**TIE THE ROPE SECURELY TO THE TOWER NEAR THE GROUND**, so that the nephelometer is suspended under the mounting bracket of the precipitation/solar radiation shield.

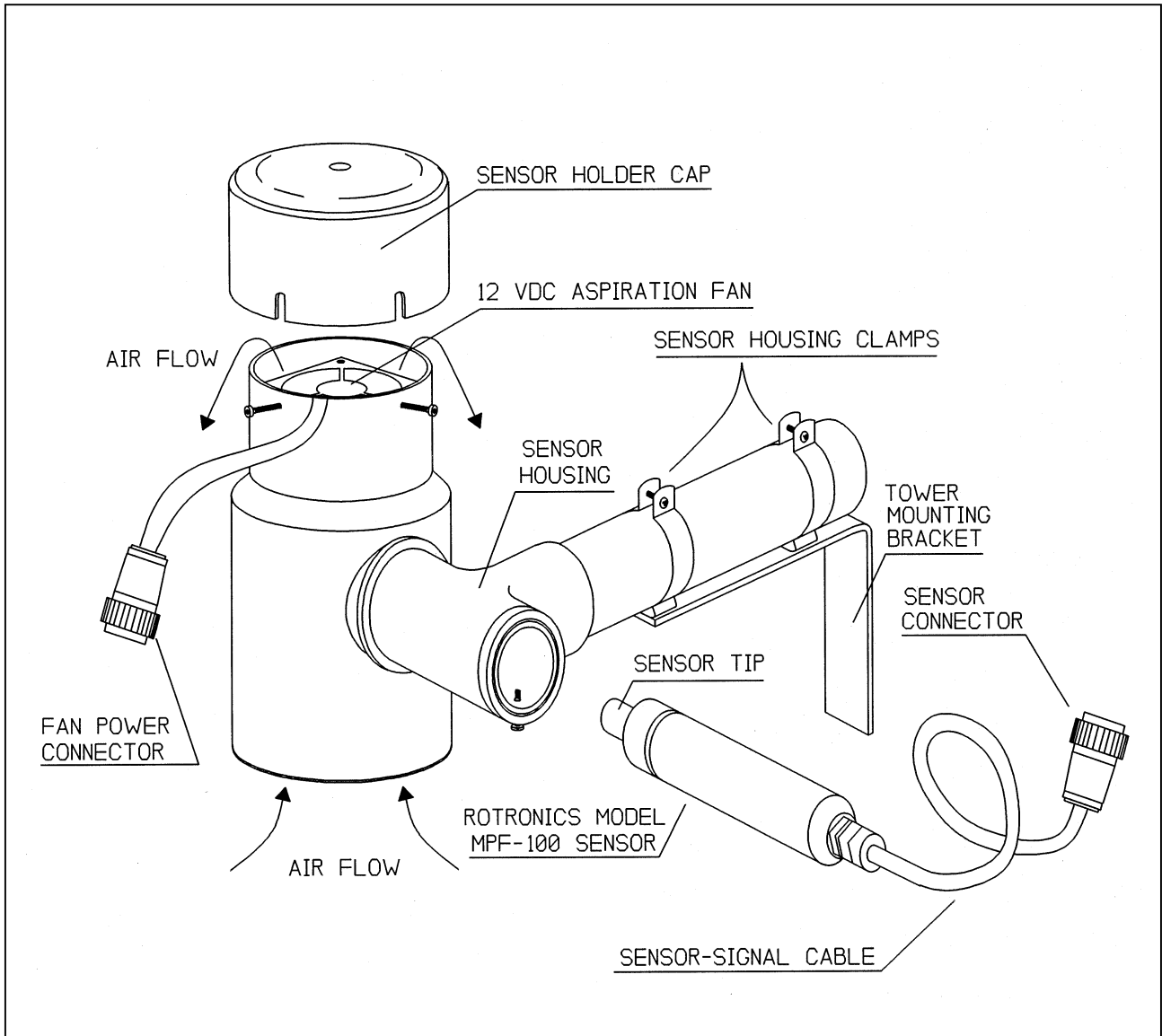

Figure 4-5. Rotronics Air Temperature/Relative Humidity Sensor Component Diagram.

**To Disconnect the AT/RH Cable:**

- use pliers (channel-lock) to keep ① connection end from AT/RH cable from moving
- use hand (thumb and index finger) to disconnect connection from DCP cable. Rotate counterclockwise

**To Connect the AT/RH Cable:**

- line up ② connection from DCP cable with ① connection from AT/RH cable
- hand tighten only, rotating ② connection from DCP cable clockwise until secure

to make the proper connection, or  
to disconnect, this is the only moving part

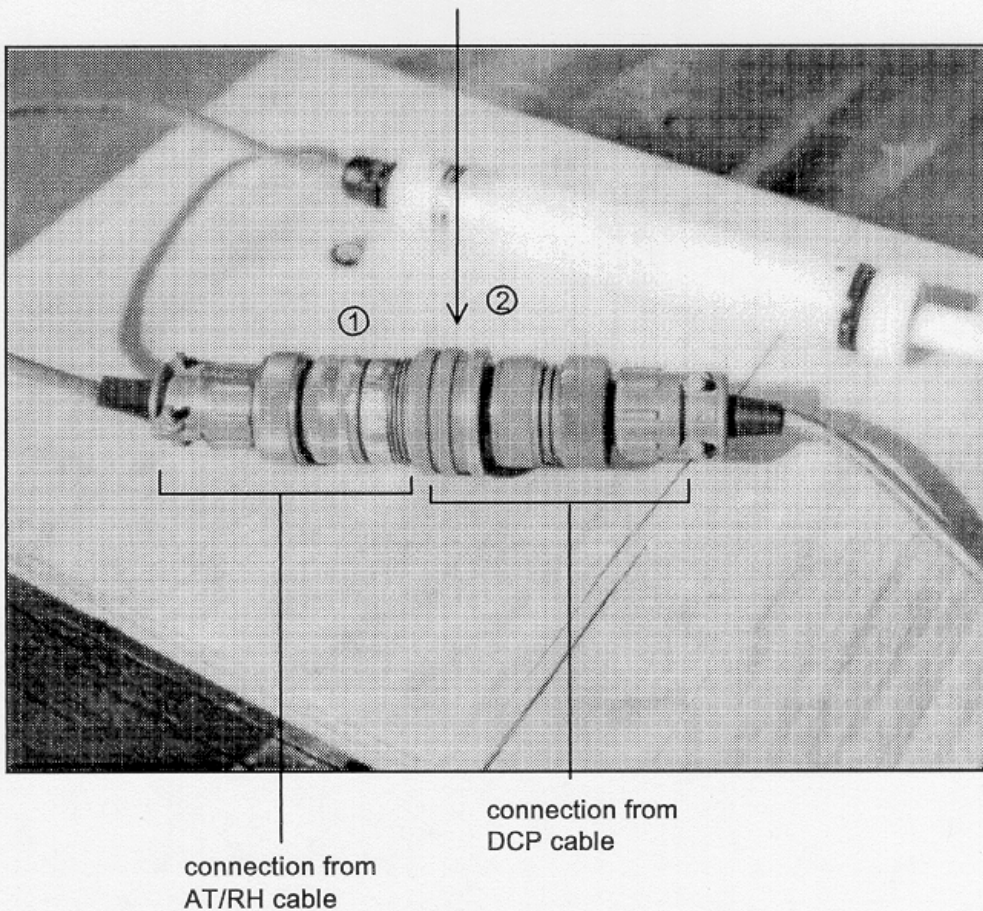

Figure 4-6. AT/RH Sensor/DCP Cable Connection Diagram.

Slide the nephelometer into the slots on the precipitation/solar radiation shield and tighten the nuts on top of the nephelometer.

Remove the hoist rope.

CONNECT

Connect the signal/power cable to the back of the nephelometer and to the data logging and control subsystem. After inspecting for dust and debris within the connectors, use a blower brush to clean the connector, if needed. Wipe a cleaning cloth around the thread inside the connectors if excess dust has collected there.

Connect the span gas hose to the back of the nephelometer.

DOCUMENT

Document installation of the instrument on the operator log sheet (see Figure 4-2).

CALIBRATE

Perform a nephelometer span/zero calibration as described in TI 4200-2000, *Calibration of Optec NGN-2 Nephelometers (IMPROVE Protocol)*.

**4.2.2 Installing the Data Logging and Control Subsystem**

Follow the procedures below when installing the data logging and control subsystem:

INSTALL

Carefully unpack the enclosure.

Open the enclosure and remove packing material (bubble-wrap) from any components secured for shipping. The following items may require unpacking:

- Campbell datalogger
- Campbell storage module
- Campbell modem
- AC surge protector
- Other loose components

Verify that all components in the enclosure are positioned properly (see Figure 4-4).

Check for loose wiring in the enclosure, especially on the datalogger terminal strips and interface circuit board.

Attach the enclosure to the tower or other mounting support using four (4) bolts or screws.



CONNECT

Connect the following cables to the AC connectors and connector panel on the bottom outside of the enclosure after inspecting for dust and debris within the connectors. Figure 4-7 and Table 4-1 describe the connectors on the subsystem. Use a blower brush to clean the connector if needed. Wipe a cleaning cloth around the thread inside the connectors if excess dust has collected there.

- AC power
- Nephelometer power/signal
- AT/RH sensor with fan power
- Telephone line
- Handar 540 DCP (if used)

Turn on or plug in the main AC power supply to the enclosure.

Program the datalogger and set the time to local standard time and Julian date. (Refer to TI 4100-3100, *Routine Site Operator Maintenance Procedures for Optec NGN-2 Nephelometer Systems (IMPROVE Protocol)*).

Verify correct operation of the datalogging system (see TI 4100-3100).

**4.2.3 Installing the Handar 540 DCP**

Any replacement data collection platform (DCP) sent from ARS will be preprogrammed and be set to the "RUN" mode. It will start collecting data as soon as the cables from the data logging and control subsystem are attached. Data will be transmitted after the antenna cable is attached and internal channel selection switches are set to the proper positions. Refer to Figure 4-3, Handar 540 DCP Component Diagram, for the location of the described parts. Follow the steps listed below to install the DCP:

INSTALL

Notify the data coordinator before going into the field to install the DCP. The data coordinator must activate the channel with the satellite service center prior to transmitting.

Attach the DCP to the tower or locate the DCP in the correct position within the shelter.

CONNECT

Connect the trickle charger or solar panel power cable to the correct position on the DCP panel. The cable from the solar panel or AC trickle charger should be connected directly to the connector labeled "solar panel trickle charger."

Connect the antenna to the gold coaxial connector located on the upper right of the input panel.

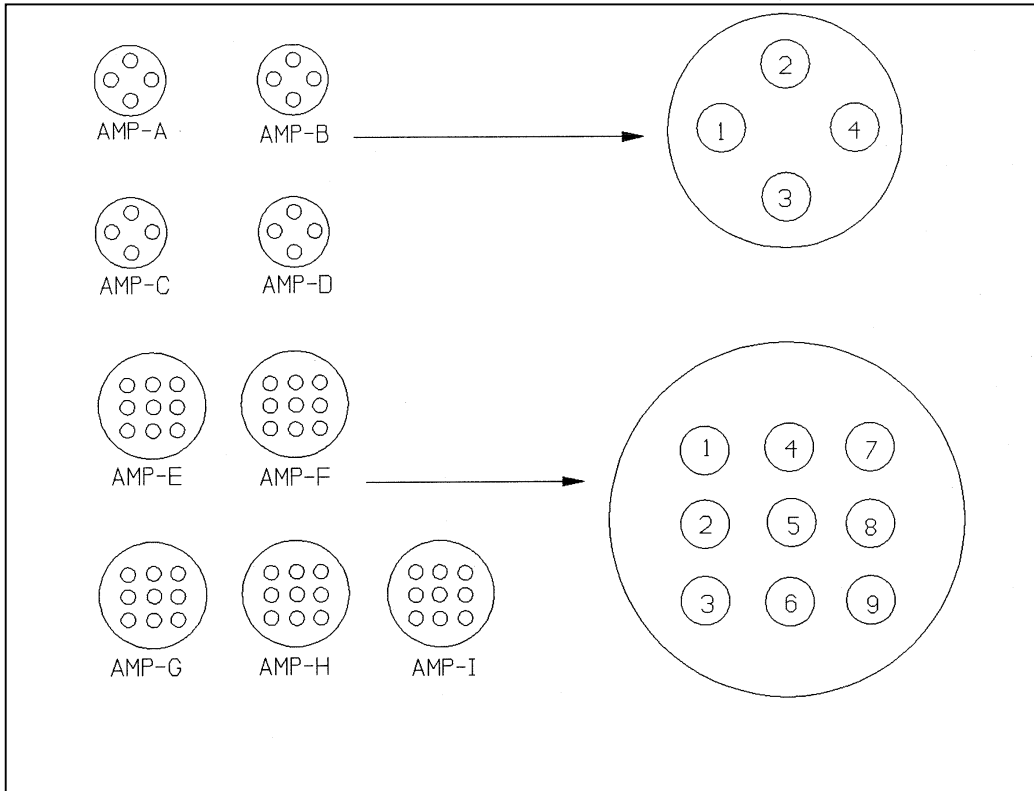

Figure 4-7. Data Logging and Control Subsystem Connector Panel Diagram (Viewed from inside the enclosure).

Table 4-1

Data Logging and Control Subsystem Connector Panel Description

Connector	Function
A	Terminal
B	Not used
C	Telephone line
D	Not used
E	Not used
F	Handar 540 DCP
G	Not used
H	Rotronics AT/RH and fan
I	Nephelometer

Connect the sensor input cable from the data logging and control subsystem to the connector labeled "TRANS". Figure 4-7 and Table 4-1 describe the connectors on the data logging and control subsystem.

Loosen the door clamps with a large, flat-blade screwdriver and open the DCP door.

Change the setting of transmission channel 1 from "900" (3 switches) to the channel requested by ARS. Channels used will be "009" for eastern sites and either "014, 038 or 002" for western sites.

Close the DCP door and re-tighten the clasps.

Check the antenna alignment, elements, and cable.

Store the DCP shipping box, unless it is needed to return a malfunctioning DCP.

#### DOCUMENT

Document the DCP installation on the operator log sheet.

Notify the data coordinator when the installation is complete.

#### **4.2.4 Installing the Rotronics Air Temperature/Relative Humidity Sensor**

The Rotronics AT/RH sensor is installed in the forced-aspirated shield on the tower. Follow the procedures below when installing the AT/RH sensor:

#### INSTALL

Slide the sensor into the shield and tighten the sensor-securing bolt.

#### CONNECT

Attach the sensor to the signal cable after inspecting for dust and debris within the two connectors. Use the blower brush to clean the connector if needed. Wipe a cleaning cloth around the thread inside the connector if excess dust has collected there. (See Figures 4-5 and 4-6 for proper connection).

Check that the signal cable is secured to the data logging and control subsystem. Refer to Figure 4-7 and Table 4-1 for data logging and control subsystem connector information.

Check that the aspiration fan power cable is secured to the data logging and control subsystem and that the aspiration fan is operating.

Check that the sensor is operating correctly. Refer to TI 4100-3100, *Routine Site Operator Maintenance Procedures for Optec NGN-2 Nephelometer Systems (IMPROVE Protocol)*.

DOCUMENT Document the installation of the sensor on the NGN-2 Nephelometer/Meteorology Log Sheet.

Call ARS to advise the data coordinator of the installation.

### 4.3 PACKING AND SHIPPING

SHIPPING CASES Shipping cases or boxes will be sent to the site for the nephelometer, DCP, and data logging and control subsystem. Shipping containers for other equipment or instruments must be found locally (or will be provided by ARS upon request).

SHIPPING Shipping costs should be charged to the air quality project's COSTS account. Other arrangements can be made if:

- UPS shipment is required and cannot be charged to the air quality account.
- There are problems meeting insurance requirements (government use of U.S. Mail).
- An air quality account does not exist.

Call ARS to discuss alternate plans for covering shipping costs.

SHIPPING MISCELLANEOUS Use packing tape to seal the shipping cases. When shipping items in a cardboard box, use nylon filament packing tape to help strengthen the box. If the shipped items are not expected at ARS, or if an explanation on the return of the items would be valuable, enclose it in an envelope within the shipping case or box.

SHIPPING ADDRESS Mail all items, including correspondence and instruments to:

Air Resource Specialists, Inc.  
1901 Sharp Point Drive, Suite E  
Fort Collins, Colorado 80525

Telephone: 970/484-7941 or 970/224-9300

Notify ARS when and with which shipper monitoring components were sent, so that the delivery date can be estimated.

QUALITY ASSURANCE/QUALITY CONTROL DOCUMENTATION SERIES	
TITLE	<b>NEPHELOMETER ANNUAL LABORATORY MAINTENANCE (IMPROVE PROTOCOL)</b>
TYPE	<b>TECHNICAL INSTRUCTION</b>
NUMBER	<b>4100-3400</b>
DATE	<b>JUNE 1995</b>

AUTHORIZATIONS		
TITLE	NAME	SIGNATURE
ORIGINATOR	E. Marty Mills	
PROJECT MANAGER	James H. Wagner	
PROGRAM MANAGER	David L. Dietrich	
QA MANAGER	Gloria S. Mercer	
OTHER		

REVISION HISTORY			
REVISION NO.	CHANGE DESCRIPTION	DATE	AUTHORIZATIONS
1.0	Add/change order of procedures.	October 1996	

## TABLE OF CONTENTS

<b><u>Section</u></b>	<b><u>Page</u></b>
1.0 PURPOSE AND APPLICABILITY	1
2.0 RESPONSIBILITIES	1
2.1 Project Manager	1
2.2 Instrument Technician	1
2.3 Field Specialist	1
3.0 REQUIRED INSTRUMENTATION, TOOLS, EQUIPMENT, AND MATERIALS	2
4.0 METHODS	3
4.1 Initial Inspection and Calibration	4
4.2 Annual Cleaning and Maintenance	8
4.3 Non-Standard Repairs	17
4.4 Operational Verification and Calibration	17
4.5 Shipping and Documentation	18
5.0 REFERENCES	18

## LIST OF FIGURES

<b><u>Figure</u></b>	<b><u>Page</u></b>
4-1 Optec NGN-2 Nephelometer Servicing Checklist	5

## **1.0 PURPOSE AND APPLICABILITY**

This technical instruction (TI) describes laboratory maintenance procedures for Optec NGN-2 nephelometers operated according to IMPROVE Protocol. The purpose of laboratory maintenance is to assure quality data capture and minimize data loss by:

- Performing and documenting a post-field instrument inspection, functional test, and calibration on each nephelometer when it is returned from a field site.
- Performing and documenting the following nephelometer maintenance procedures:
  - Nephelometer disassembly and cleaning
  - Preventative maintenance
  - Non-standard repairs
- Performing and documenting factory-authorized upgrades

This TI, as referenced from SOP 4100, *Nephelometer Maintenance, (IMPROVE Protocol)*, specifically describes nephelometer maintenance procedures to be performed during annual laboratory servicing of the Optec NGN-2 nephelometer.

## **2.0 RESPONSIBILITIES**

### **2.1 PROJECT MANAGER**

The project manager shall:

- Verify that laboratory maintenance is performed according to the required schedule.
- Verify that the Optec NGN-2 Nephelometer Servicing Checklist has been completed following the servicing and that all servicing functions were performed properly.
- Ensure that all instruments are serviced in accordance with the procedures described in this technical instruction.

### **2.2 INSTRUMENT TECHNICIAN**

The instrument technician shall:

- Perform all laboratory servicing and maintenance procedures described in this TI.
- Document all servicing and maintenance work using the Optec NGN-2 Nephelometer Servicing Checklist.

### **2.3 FIELD SPECIALIST**

The field specialist shall provide technical support to the instrument technician in identifying and correcting instrument functional problems.

The data coordinator shall provide the instrument technician with a description of any instrument problems suspected or identified during the time the instrument operated in the field.

### **3.0 REQUIRED INSTRUMENTATION, TOOLS, EQUIPMENT, AND MATERIALS**

Specific instrumentation, tools, equipment, and materials required for nephelometer servicing includes:

- Electronics laboratory instrumentation:
  - Digital voltmeter (4 1/2 digit display)
  - Dual channel oscilloscope (20 MHz bandwidth)
  - Regulated power supply (12 VDC @ 10 amps)
- Optical laboratory equipment instrumentation:
  - Variable transformer base
  - Tungsten illuminator
  - Adapter ring
  - Alignment target
- Specialized nephelometer servicing support equipment:
  - IBM PC-compatible computer terminal (network access to PROCOMM communications software)
  - Support circuit board test fixture
  - Reference temperature sensor
  - Flowmeter
- Cleaning and servicing supplies:
  - Contact cleaner
  - Flux remover
  - Canned air
  - Liquid glass cleaner
  - Kimwipes (low linting tissue)
  - Microfiber optical cleaning cloth



- Ultrasonic cleaner
- Black paint (Krylon, Ultra flat black 1602)
- White paint (Krylon, Glossy White 1501)
- Soft cloth
- Cement glue
- Silicone lubricant
- Water for cleaning cloth
- Hand tools:
  - Drill and jigs
  - Wire brush
  - Small, medium, and large flat-blade screwdriver
  - Small and medium adjustable wrench
  - Allen wrench set
  - Small wire cutter and stripper
  - Pliers (standard, needle nose, and long nose)
  - Alignment tool (flat-blade tip)
  - Contact extraction tool (for Amp Series 1 circular plastic connectors)
  - Soldering station
- Servicing forms:
  - Optec NGN-2 Nephelometer Servicing Checklist
  - *Model NGN-2 Open-Air Integrating Nephelometer Technical Manual for Theory of Operation and Operating Procedures* (Optec, Inc.)

#### **4.0 METHODS**

Each nephelometer returned from a field site for annual laboratory maintenance is inspected and tested prior to initiating any servicing procedures that could invalidate the instrument calibration. Post-field inspecting and testing is performed immediately after the instrument is received at ARS. All servicing procedures are documented on the Optec NGN-2 Nephelometer Servicing Checklist (see Figure 4-1). This section contains five (5) major subsections, which are listed on the checklist:

- 4.1 Initial Inspection and Calibration
- 4.2 Annual Cleaning and Maintenance
- 4.3 Non-Standard Repairs
- 4.4 Operational Verification and Calibration
- 4.5 Shipping and Documentation

The instrument technician shall complete the following general information on the checklist, prior to performing servicing:

- NGN-2 serial number
- Owner/Network of the instrument
- Date of servicing
- Last operational period of the instrument
- Service technician performing the servicing
- Last site the instrument operated at
- Service type (annual, repair, warranty)

#### 4.1 INITIAL INSPECTION AND CALIBRATION

Initial inspection and calibration of a nephelometer includes the following procedures:

**POST-OPERATIONAL CALIBRATION** The post-operational/pre-maintenance calibration documents the condition of the nephelometer before any maintenance is performed. Perform a simple and complete calibration as described in TI 4200-2000, *Calibration of Optec NGN-2 Nephelometers (IMPROVE Protocol)*. Attach the NGN-2 calibration form and the printed calibration results to the checklist.

**POST-OPERATIONAL INSPECTION** Inspect the nephelometer exterior, all interior chambers, and the measurement chamber for contamination, dirt, component failures, and other items that affect the operation of the nephelometer. Specifically, the following should be checked:

##### Exterior

Note any damage to or contamination of the following:

- Mounting studs
- Clean air filter assembly and threaded mounting stud (remove and examine interior)
- Span gas inlet assembly
- Door

**OPTEC NGN-2 NEPHELOMETER SERVICING CHECKLIST**

NGN-2 Serial Number: \_\_\_\_\_ Owner/Network: \_\_\_\_\_  
Date: \_\_\_\_\_ Operational Period: \_\_\_\_\_  
Service Technician: \_\_\_\_\_ Last Site: \_\_\_\_\_

Service Type:  Annual  Repair Service  Warranty Service

Completed    See Comments

**Initial Inspection and Calibration:**

Post-operational Calibration (attach NGN-2 Calibration Form)  
  Post-operational Inspection. Describe the "as returned" condition:

Exterior: \_\_\_\_\_  
\_\_\_\_\_

Interior (electronics and lower chamber): \_\_\_\_\_  
\_\_\_\_\_

Measurement chamber: \_\_\_\_\_  
\_\_\_\_\_

Comments: \_\_\_\_\_  
\_\_\_\_\_  
\_\_\_\_\_

Exterior

**Annual Cleaning and Maintenance:**

Clean outer surfaces  
  Clean rain detector contacts  
  Disassemble front, back, and bottom  
  Exterior (white gloss) paint touch up

Electronics Chamber

Clean electronics chamber  
  Replace D to A analog output chips  
  Replace serial communication chips  
  EPROM upgrade; to EPROM \_\_\_\_\_  
  Check jumper settings (circle one): **J1:** 5V 10V    **J2:** 5V 10V  
  Upgrade rain sensor sensitivity  
  Upgrade transient voltage suppressors

Lower Chamber

Clean lower chamber  
  Replace sample fan  
  Replace sample fan guard (if corroded)  
  Upgrade to longer feet  
  Inspect clean air pump and tubing for moisture and contamination  
  Upgrade cone light trap  
  Clean light trap  
  Replace light trap wick (if needed)

Figure 4-1. Optec NGN-2 Nephelometer Servicing Checklist.

---

**OPTEC NGN-2 NEPHELOMETER SERVICING CHECKLIST (continued)**

Completed    See Comments

Optical Chamber

**Annual Cleaning and Maintenance (continued):**

- |                          |                          |  |
|--------------------------|--------------------------|--|
| <input type="checkbox"/> | <input type="checkbox"/> | Clean optical chamber                        |
| <input type="checkbox"/> | <input type="checkbox"/> | Clean telescope lens                         |
| <input type="checkbox"/> | <input type="checkbox"/> | Clean light detector                         |
| <input type="checkbox"/> | <input type="checkbox"/> | Upgrade aperture ring screwed to manifold    |
| <input type="checkbox"/> | <input type="checkbox"/> | Interior (flat black) paint touch up         |
| <input type="checkbox"/> | <input type="checkbox"/> | Replace chamber door drain wicks (if needed) |

Lamp Assembly

- |                          |                          |                                    |
|--------------------------|--------------------------|------------------------------------|
| <input type="checkbox"/> | <input type="checkbox"/> | Clean lamp assembly                |
| <input type="checkbox"/> | <input type="checkbox"/> | Inspect lamp housing               |
| <input type="checkbox"/> | <input type="checkbox"/> | Upgrade lamp housing modifications |
| <input type="checkbox"/> | <input type="checkbox"/> | Install new lamp                   |
| <input type="checkbox"/> | <input type="checkbox"/> | Replace chopper motor              |

Calibration System

- |                          |                          |   |
|--------------------------|--------------------------|---|
| <input type="checkbox"/> | <input type="checkbox"/> | Upgrade span gas valve mounting and connections |
| <input type="checkbox"/> | <input type="checkbox"/> | Clean the clean air filter housing              |
| <input type="checkbox"/> | <input type="checkbox"/> | Upgrade removable clean air filter assembly     |
| <input type="checkbox"/> | <input type="checkbox"/> | Replace clean air filter                        |
| <input type="checkbox"/> | <input type="checkbox"/> | Upgrade door motor                              |
| <input type="checkbox"/> | <input type="checkbox"/> | Reassemble front, back, and bottom              |

Optical and Electronic Alignment

- |                          |                          |  |
|--------------------------|--------------------------|--|
| <input type="checkbox"/> | <input type="checkbox"/> | Focus telescope                            |
| <input type="checkbox"/> | <input type="checkbox"/> | Align optics                               |
| <input type="checkbox"/> | <input type="checkbox"/> | Verify chamber temperature sensor          |
| <input type="checkbox"/> | <input type="checkbox"/> | Test and adjust zero-cross detector timing |

Comments: \_\_\_\_\_  
\_\_\_\_\_  
\_\_\_\_\_

**Non-Standard Repairs:**

- |                          |                          |       |
|--------------------------|--------------------------|-------|
| <input type="checkbox"/> | <input type="checkbox"/> | _____ |
| <input type="checkbox"/> | <input type="checkbox"/> | _____ |
| <input type="checkbox"/> | <input type="checkbox"/> | _____ |
| <input type="checkbox"/> | <input type="checkbox"/> | _____ |
| <input type="checkbox"/> | <input type="checkbox"/> | _____ |
| <input type="checkbox"/> | <input type="checkbox"/> | _____ |
| <input type="checkbox"/> | <input type="checkbox"/> | _____ |
| <input type="checkbox"/> | <input type="checkbox"/> | _____ |

Comments: \_\_\_\_\_  
\_\_\_\_\_  
\_\_\_\_\_

---

Figure 4-1. (Continued). Optec NGN-2 Nephelometer Servicing Checklist.

---

**OPTEC NGN-2 NEPHELOMETER SERVICING CHECKLIST (continued)**

Completed    See Comments

**Operational Verification and Calibration:**

- |                          |                          |   |
|--------------------------|--------------------------|---|
| <input type="checkbox"/> | <input type="checkbox"/> | Circuit board integrity checked                           |
| <input type="checkbox"/> | <input type="checkbox"/> | Serial output verified                                    |
| <input type="checkbox"/> | <input type="checkbox"/> | Analog output verified                                    |
| <input type="checkbox"/> | <input type="checkbox"/> | Document user parameter settings:                         |
|                          |                          | SN                            _____    Auto Test          |
|                          | _____                    | Run Mode                    _____    Total Run Time       |
|                          | _____                    | Intervals                    _____    Low Lamp Limit      |
|                          | _____                    | Date & Time                    _____    Fog Limit         |
|                          | _____                    | Auto Span                    _____    Analog-1 Multiplier |
|                          | _____                    | Stored Baud Rate            _____                         |
| <input type="checkbox"/> | <input type="checkbox"/> | Post-maintenance calibration (attach results)             |
| <input type="checkbox"/> | <input type="checkbox"/> | 24-hour operational test                                  |

Comments: \_\_\_\_\_  
\_\_\_\_\_  
\_\_\_\_\_

**Shipping and Documentation:**

- |                          |                          |   |
|--------------------------|--------------------------|---|
| <input type="checkbox"/> | <input type="checkbox"/> | Instrument return shipped:                              |
|                          |                          | Date: _____   |
|                          |                          | Carrier: _____  |
|                          |                          | Type: _____   |
|                          |                          | Weight: _____   |
|                          |                          | Tracking No.: _____                                     |
| <input type="checkbox"/> | <input type="checkbox"/> | Service documentation forwarded to ARS Tech. Accounting |
| <input type="checkbox"/> | <input type="checkbox"/> | Hard copy of service documentation filed                |
| <input type="checkbox"/> | <input type="checkbox"/> | Service documentation records entered into database:    |
|                          |                          | Date: _____   |
|                          |                          | Entered by: _____                                       |

Comments: \_\_\_\_\_  
\_\_\_\_\_  
\_\_\_\_\_

---

Figure 4-1. (Continued). Optec NGN-2 Nephelometer Servicing Checklist.

- Door gasket, screen, rain detector
- Feet
- Light trap (remove and examine interior)
- Sample fan and guard
- Lamp tray assembly (wires, lamp holder)

Interior (Electronics chamber)

Note damage to any of the circuit boards, wiring, connectors, or other components, including:

- Support circuit board
- Computer circuit board
- Direct light/temperature sensor circuit board
- Scattered light detector circuit board and housing
- Clean air pump and tubing
- Solenoid
- Span gas valve
- Door motor

Measurement Chamber

Remove the door and measurement chamber side panel. Examine the measurement chamber for the following:

- Dirt and/or insect debris on the walls and floor
- Damage to the aperture ring, baffle, or other components
- Paint peeling from any painted surface
- Evidence of water contamination

Note all inspection findings on the servicing checklist before continuing with system cleaning.

## **4.2 ANNUAL CLEANING AND MAINTENANCE**

Annual cleaning and maintenance of a nephelometer includes the following procedures:

### Exterior

CLEAN OUTER SURFACES	Clean the outer surfaces of the nephelometer with a mild cleaner and a soft cloth.
CLEAN RAIN DETECTOR CONTACTS	Clean the rain detector contacts on the door with contact cleaner and a wire brush.
DISASSEMBLE NEPHELOMETER	Disassemble the front, back, and bottom of the nephelometer.
PAINT EXTERIOR	If necessary, paint the exterior with white gloss paint (Krylon, Glossy White 1501).

### Electronics Chamber

CLEAN ELECTRONICS CHAMBER	Remove accumulated dust from the electronics chamber with compressed air, a mild cleaner, and a soft cloth. Clean residue from the circuit boards with residue-free canned contact cleaner.
REPLACE D/A CHIPS	Replace the two digital-to-analog (D/A) output chips on the main circuit board. The chips are labeled U20 and U21 and are type AD7248AQ. Verify the new chips are oriented correctly in the sockets.
REPLACE SERIAL COMMUNICATION CHIPS (MC1489).	Replace the two serial communication chips on the main circuit board. The chips are labeled U16 (type MC1488) and U17 (type MC1489). Verify the new chips are oriented correctly in the sockets.
EPROM UPGRADE	The current EPROM version in use at all IMPROVE sites is NEPH1056. Newer versions (including NEPH1071) contain several errors and should not be used. Verify that the replacement EPROM is oriented correctly in the socket.
CHECK JUMPER SETTINGS	Verify the analog output range jumper settings on the computer circuit board. All IMPROVE nephelometers should be set to the 5 volt range for the A1 and A2 channels. The jumper position for the 5 volt range are the middle and lower pins on the jumper header.
UPGRADE RAIN SENSITIVITY SENSOR	The rain sensor sensitivity enhancement includes three modifications to the nephelometer: <ul style="list-style-type: none"><li>• Cement two triangular water diverters to the rain detector on the nephelometer door.</li><li>• Replace resistor R9 (787K<math>\Omega</math>) on the support circuit board with a 3M<math>\Omega</math> resistor.</li><li>• Replace resistor R7 (1K<math>\Omega</math>) on the support circuit board with a 2K<math>\Omega</math> resistor.</li></ul>

UPGRADE  
TRANSIENT  
VOLTAGE  
SUPPRESSORS

Install the transient voltage suppressors on the following connectors:

- Interface circuit board J4-1, J5-6, and J5-12
- Single Board Computer (SBC), J3-2, J3-3, J4-2, and J4-5, ground all suppressors to chassis ground

Lower Chamber

CLEAN LOWER  
CHAMBER

Clean the lower chamber with compressed air, liquid glass cleaner, and a soft cloth.

REPLACE SAMPLE  
FAN AND  
FAN GUARD

Replace the sample fan by removing the four screws securing the fan and fan blade guard. Verify that the polarity of the fan voltage is correct (red wire positive) and that the fan mounted will exhaust air from the inside of the measurement chamber. Replace the fan blade guard if it is corroded or otherwise damaged.

UPGRADE TO  
LONGER FEET

Longer feet are required when the cone light trap has been installed on the nephelometer. The longer feet replace the existing feet using new longer screws.

INSPECT CLEAN  
AIR PUMP AND  
TUBING

Inspect the clean air pump and tubing for moisture and contamination. Replace contaminated tubing.

Connect the pump to a 12 VDC supply and test the input and output using a flowmeter. If the flow is less than 3.5 lpm in either direction, inspect and replace as necessary the intake and exhaust valves and the diaphragm. If there is nothing apparently wrong with those, then replace the pump. If any of the items needed replacement, note that in "non-standard repairs."

UPGRADE CONE  
LIGHT TRAP

The cone light trap is a simple replacement for the existing factory light trap. The cone light trap consists of two pieces: the base and the bottom. The procedures for replacing the light trap include:

- Remove the two screws securing the existing light trap to the nephelometer.
- Attach the base of the cone light trap to the nephelometer using new shorter screws.
- Screw the bottom of the cone light trap onto the base piece.

CLEAN THE  
LIGHT TRAP

Clean the light trap with compressed air and a damp cloth.

REPLACE LIGHT  
TRAP WICK

Replace the light trap wick if it is moldy, damaged, or otherwise contaminated.



### Optical Chamber

#### CLEAN THE OPTICAL CHAMBER

Remove dust accumulation using compressed air and a water-moistened, soft lint-free cloth. Excessive dirt on or paint peeling off of the walls of the optical (measurement) chamber may require repainting.

#### CLEAN THE TELESCOPE LENS

Clean the telescope lens in the ultrasonic cleaner as follows:

- Remove the scattered light detector circuit board from the telescope by loosening the two small Allen screws. Loosen the three large Allen screws and remove the telescope.
- Remove the lens from the telescope by loosening the two set screws holding it in place.
- Clean the lens for 10 minutes.
- Place the lens back on the telescope and tighten the two set screws.
- Do not reinstall the telescope at this time.

#### CLEAN THE DIRECT LIGHT DETECTOR

Clean the direct light detector with an optical cleaning cloth.

#### UPGRADE THE APERTURE RING SCREWED TO MANIFOLD WALL

The aperture ring in the optical chamber defines the cone of light illuminating the air being measured. The glue securing the aperture ring in existing nephelometers can fail. Secure the aperture ring to the manifold wall as follows:

- Remove the manifold wall from the nephelometer.
- Place a drill jig over the aperture ring and align holes horizontally.
- Drill holes through the ring and wall.
- Attach the ring with #2 screws.
- Remove the jig.

#### PAINT INTERIOR

If necessary, paint the measurement chamber walls and baffle with flat black paint.

#### REPLACE CHAMBER DOOR WICKS

Replace the measurement chamber door drain wicks if they are moldy, damaged, or otherwise contaminated.

## Lamp Assembly

### CLEAN LAMP ASSEMBLY

Clean the lamp assembly with compressed air and a damp cloth.

### INSPECT LAMP HOUSING

Inspect the lamp housing assembly. Repair or replace any broken components or bare wires. Check for loose solder connections.

### UPGRADE LAMP HOUSING MODIFICATIONS

The modifications to the lamp housing allow the housing and lamp to be removed from the nephelometer as a unit for easy lamp replacement. The modifications minimize damage to the lamp wires that frequently occurred with the older system. The following procedures describe the lamp housing modifications:

- Drill a 11/16" hole 6" from the bottom and 1 3/8" from the left side of the back.
- Place a water-tight strain relief in this hole.
- Drill a 5/8" hole in the center of the lamp housing plate.
- Place a CONXALL 2-pin waterproof plug in this hole.
- Use two conductor #18 PVC-coated cable from the support board out through the strain relief, then connect a CONXALL waterproof socket on cable.
- Connect two #18 wires to the plug.
- Connect #6 stud crimp connectors to wires.
- Attach the studs with #3 metric screws to the lamp socket.

### INSTALL NEW LAMP REPLACE CHOPPER MOTOR

Install a new lamp.

Remove the old chopper motor and blade assembly by removing the two screws securing the chopper motor. Remove the blade from the old motor and place on the new motor. Install the new motor and blade assembly and verify that the blade spins freely when it is installed.

## Calibration System

### UPGRADE SPAN GAS VALVE

To accommodate the large orifice span gas valve, existing fittings and tubing must be modified. Procedures for performing these modifications and installing the large orifice span gas valve are as follows:

- Remove the old valve and external elbow.
- Disconnect all tubing at the tee connector.

- Disconnect tubing from the chamber inlet.
- Cut the tubing removed from the chamber inlet to a length of 1" and reconnect to the chamber inlet.
- Connect one in-line nipple of tee to the tubing on the chamber inlet connection.
- Connect a nylon 90° fitting to the opposite in-line nipple of the tee connector with a 1" length of tubing.
- Cut existing tubing from the zero air pump (inlet) to fit a 90° fitting.
- Attach a 2" length of tubing to the 90° nipple of the tee connector.
- Attach the drill jig to the existing valve mounting hole.
- Drill three 9/64" holes as located by jig.
- Remove the drill jig.
- Drill out the threaded hole with a size Z drill.
- Attach the valve mounting plate to the outside of the nephelometer back wall.
- Attach the 1/4" flare fitting to the 1/8" NPT long nipple. Use PTFE thread-seal tape.
- Attach the 1/4" barb nipple to the valve outlet.
- Attach the valve nipple to the tee connector.
- Place the long nipple through the mounting plate and connect to the valve inlet port.
- Tighten all fittings and make sure the 1/4" flare is facing downward.
- Push the flare fitting flush to the mounting plate and tighten the two set screws.

CLEAN THE  
CLEAN AIR  
FILTER ASSEMBLY

Clean the clean air filter assembly with a soft cloth. Relubricate o-rings with silicone lubricant.

UPGRADE THE  
CLEAN AIR  
FILTER ASSEMBLY

The removable clean air filter assembly is a simple replacement for the existing single-use clean air filter. Verify that a filter cartridge is installed in the assembly during replacement.

REPLACE  
CLEAN AIR FILTER

Replace the clean air filter cartridge in the clean air filter assembly.

UPGRADE DOOR  
MOTOR

The older door motors manufactured by SOHO are no longer available. Upgrading the door motor includes installing a new motor manufactured by Globe, and modifying the mounting plate and interface circuit board. The following procedures describe the door motor upgrade modifications:

- Remove the old door motor and mounting plate.
- Enlarge the mounting plate pilot hole to 1/2 inch.
- Connect new wires approximately 2 1/2 inches long to the motor terminals using red wire on the positive terminal and black wire on the negative terminal. Connect two molex terminals to the opposite ends and replace the terminal housing from the old motor on the new terminals.
- Replace the mounting plate and the door motor back in the nephelometer.
- Remove the interface circuit board and replace R-12 with a 12 Ohm, 10 Watt resistor, and install a 100 Ohm, 1 Watt resistor between the collector and emitter of Q-14.
- Replace the interface circuit board.

REASSEMBLE  
NEPHELOMETER

Reassemble the front, back, and bottom of the nephelometer.

Optical and Electronic Alignment

FOCUS  
TELESCOPE

Focus the instrument as follows:

- Place the light source (Tungsten illuminator) in a horizontal position on a variable transformer base, and use an adapter ring to hold the telescope on the light source.
- Place a white card 10 1/2" in front of the telescope lens.
- If the spot projected onto the card is not focused sharply, loosen the two set screws holding the field aperture, and adjust the aperture back and forth to achieve the sharpest image, and tighten the two set screws.

ALIGN OPTICS

Verify the optical alignment is correct as follows:

- To install the telescope, put a small amount of lubricant around the base of the telescope. Insert the telescope in the telescope mount. Tighten the three alignment screws.

- Use the telescope adapter ring to place the light source in the telescope.
- Place the alignment target in the light trap hole in the measurement chamber.
- Verify the location of the alignment light source on the target. Adjust the alignment using the three large Allen screws on the telescope.
- Remove the light source and target. Replace the scattered light detector circuit board.

When proper alignment is obtained, tighten the three alignment screws.

#### VERIFY CHAMBER TEMPERATURE SENSOR

Verify correct operation of the chamber temperature sensor as follows:

- Connect nephelometer test cable to the nephelometer, the computer serial port (COM1), and to the 13.8 VDC power supply.
- Invoke the PROCOMM communications software on the computer. Set the communications parameters to N81 at 9600 baud.
- Turn the nephelometer power supply "ON." Observe the nephelometer Power-On-Self-Test (POST) information showing the user parameter settings.
- Interrupt the nephelometer by entering ^C on the computer within three seconds of starting the nephelometer. The nephelometer should respond with a ">" prompt.
- Place a reference temperature sensor in contact with the direct light sensor block.
- Turn on the nephelometer and enter the following commands at the nephelometer ">" prompt: **TEMP-TEST**
- Compare the temperature measured by the nephelometer with the reference measurement. If the measurements differ by more than 0.5°C, adjust the nephelometer temperature potentiometer until they match.
- Replace the removable wall on the optical chamber.

ZERO-CROSS  
DETECTOR TIMING  
ADJUSTMENT

Verify correct zero-cross detector timing as follows:

- Set the oscilloscope as follows:

Channel 1: 5 V/Div DC  
Channel 2: 0.2 V/Div DC  
Sweep rate: 10 ms/Div  
Trigger: External

- Connect the oscilloscope external trigger input (EXT) to the cathode of the zener diode on the direct light/temperature sensor circuit board. Connect the ground to the anode.
- Connect the oscilloscope channel 1 input (CH1) to pin #2 of the A/D converter chip (U15). Pin #2 of the A/D converter indicates the A/D converter status (Busy or Not Busy). During integration of the scattered light signal (14 seconds), 15 conversions are performed and CH1 of the oscilloscope will display a string of 15 pulses (each pulse indicating a sample conversion taking place). During integration of the direct light(1 second), eight(8) conversions are performed and eight(8) pulses are displayed. Connect the CH1 ground to test point #2 (TP2).
- Connect the oscilloscope channel 2 input (CH2) to test point #1 (TP1). Test point #1 is the output of the analog multiplexer which selects the A/D converter input signal (scattered light or direct light). The oscilloscope display of this signal is a full cycle of the photometer output, showing both the lamp "on" and lamp "off" phase of the A/D converter input signal.
- Unscrew and remove the light trap from the light trap mounting ring on the bottom of the nephelometer.
- Insert a "light scattering" material (a crumpled, clean Kimwipe works quite well) into the inside of the light trap mounting ring.
- Turn the nephelometer on and enter the following commands at the nephelometer ">" prompt:

**LAMP-ON 1 TO INTEG WORK**, then press the "ENTER" key.

- If the zero-cross detector output is properly aligned, the 15 CH1 pulses (A/D converter status) will be centered in the positive going half-cycle during the lamp "on" phase and in the negative going half-cycle during the lamp "off" phase.
- If the A/D converter status pulses are not centered, adjust the zero-cross phase potentiometer until they are.

### 4.3 NON-STANDARD REPAIRS

Repairs not covered under Section 4.2, Annual Cleaning and Maintenance, are considered non-standard repairs. Non-standard repairs include, but are not limited to, repair or replacement of the following components:

- Zero air pump
- Circuit board repair
- Optics
- Span gas valve
- Structural components

Note all non-standard repairs on the servicing checklist.

### 4.4 OPERATIONAL VERIFICATION AND CALIBRATION

Operational verification and calibration is performed after all servicing is complete and includes the following:

#### CIRCUIT BOARD INTEGRITY

Verify that all circuit boards are secured inside the nephelometer with their mounting screws and that all connectors are in place.

#### VERIFY SERIAL COMMUNICATIONS

Verify that the nephelometer serial communications function correctly as follows:

- If the ">" prompt appears, serial communications are working correctly.
- If the POST does not appear or if "^C" does not interrupt the nephelometer, check the cable connections and PROCOMM communication settings. If all is in order, replace the serial chips (U16 and U17) on the computer circuit board.

#### VERIFY ANALOG OUTPUTS

Verify correct operation of the analog outputs as follows:

- Verify that serial communications are working correctly.
- Connect a digital voltmeter to the nephelometer test cable A1 channel wires.
- Enter **1000 D/A-A1**. Measure the A1 voltage. It should be 0.500 VDC on the 5 volt range and 1.000 VDC on the 10 volt range.
- Enter **1000 D/A-A2**. Measure the A2 voltage. It should be 0.500 VDC on the 5 volt range and 1.000 VDC on the 10 volt range.

- If the A1 or A2 output do not work correctly, replace the appropriate chip (U20 or U21) on the computer circuit board.

DOCUMENT USER PARAMETERS Document the user parameter settings that appear on the computer during the POST on the servicing checklist.

POST MAINTENANCE CALIBRATION The post maintenance calibration verifies correct operation of the nephelometer prior to shipping. Perform a simple and complete calibration as described in TI 4200-2000, *Calibration of Optec NGN-2 Nephelometers (IMPROVE Protocol)*. Attach the NGN-2 calibration form and the printed calibration results to the servicing checklist.

24-HOUR OPERATIONAL TEST Run the nephelometer in its normal operational mode for 24 hours to verify correct functioning.

#### **4.5 SHIPPING AND DOCUMENTATION**

Nephelometer shipping is detailed in TI 4100-3375, *Replacing and Shipping Nephelometer System Components*. Enter all nephelometer laboratory maintenance documentation, including the servicing checklist and calibration results in the appropriate quality assurance database.

#### **5.0 REFERENCES**

Optec, Inc., 1993, Model NGN-2 Open-Air Integrating Nephelometer Technical Manual for Theory of Operation and Operating Procedures, Revision 4, November, Lowell, MI.