

| QUALITY ASSURANCE/QUALITY CONTROL DOCUMENTATION SERIES |   |
|--|---|
| TITLE  | <b>INSTALLATION AND SITE DOCUMENTATION FOR OPTICAL MONITORING EQUIPMENT</b> |
| TYPE   | <b>STANDARD OPERATING PROCEDURE</b>   |
| NUMBER   | <b>4070</b>   |
| DATE   | <b>JULY 1996</b>  |

| AUTHORIZATIONS  |                   |           |
|-----------------|-------------------|-----------|
| TITLE           | NAME              | SIGNATURE |
| ORIGINATOR      | Gloria S. Mercer  |           |
| PROJECT MANAGER | Mark Tigges       |           |
| PROGRAM MANAGER | David L. Dietrich |           |
| QA MANAGER      | Gloria S. Mercer  |           |
| OTHER           |                   |           |

| REVISION HISTORY |                                    |              |                |
|------------------|------------------------------------|--------------|----------------|
| REVISION NO.     | CHANGE DESCRIPTION                 | DATE         | AUTHORIZATIONS |
|                  | Reviewed; no changes necessary.    | July 1997    |                |
|                  | Reviewed; no changes necessary.    | July 1998    |                |
|                  | Reviewed; no changes necessary.    | July 1999    |                |
|                  | Reviewed; no changes necessary.    | July 2000    |                |
|                  | Reviewed; no changes necessary.    | October 2001 |                |
|                  | Reviewed; no changes necessary.    | October 2002 |                |
| 0.1              | Small changes to materials needed. | October 2003 |                |
|                  | Reviewed; no changes necessary.    | October 2004 |                |

## TABLE OF CONTENTS

| <b><u>Section</u></b>  | <b><u>Page</u></b> |
|--|--------------------|
| 1.0 PURPOSE AND APPLICABILITY  | 1                  |
| 2.0 RESPONSIBILITIES   | 1                  |
| 2.1 Program Manager  | 1                  |
| 2.2 Project Manager  | 1                  |
| 2.3 Field Specialist   | 2                  |
| 2.4 Data Analyst   | 2                  |
| 2.5 Local (On-Site) Contact  | 2                  |
| 3.0 REQUIRED EQUIPMENT AND MATERIALS                                   | 3                  |
| 3.1 Equipment and Materials Required for Nephelometer Installations    | 3                  |
| 3.2 Equipment and Materials Required for Transmissometer Installations | 4                  |
| 4.0 METHODS  | 5                  |
| 4.1 Site Preparation and Communication                                 | 5                  |
| 4.2 Installation Methods and Procedures                                | 6                  |
| 4.3 Operator Training  | 6                  |
| 4.4 Site Documentation and Documentation Archival                      | 6                  |

## **1.0 PURPOSE AND APPLICABILITY**

This standard operating procedure (SOP) outlines the general procedures regarding installation and site documentation of optical monitoring instrumentation operated according to IMPROVE Protocol. Optical monitoring sites include those equipped with an Optec LPV transmissometer and/or Optec NGN nephelometer.

To assure quality data capture and minimize data loss, site installation and documentation procedures include:

- Installing the instrumentation, shelters, and support components in a standard configuration to ease data collection, troubleshooting, and servicing.
- Performing thorough on-site specification measurements.
- Documenting site specification measurements and other site-related information.

The following technical instructions (TIs) provide detailed information regarding installing optical monitoring equipment or documenting optical site information:

- TI 4070-3000     *Installation of Optec NGN-2 Nephelometer Systems (IMPROVE Protocol)*
- TI 4070-3001     *Site Documentation for Optec NGN-2 Nephelometer Systems*
- TI 4070-3010     *Installation and Site Documentation for Optec LPV-2 Transmissometer Systems (IMPROVE Protocol)*

## **2.0 RESPONSIBILITIES**

### **2.1 PROGRAM MANAGER**

The program manager shall review site preparation, installation requirements, and the installation schedule with the project manager.

### **2.2 PROJECT MANAGER**

The project manager shall:

- Review site preparation, installation requirements, and the installation schedule with the program manager and/or the project-specific Contracting Officer's technical Representative (COTR) as required.
- Schedule the system installation.
- Review final site configuration plans presented by the field specialist.
- Review the completed site documentation forms for completeness and accuracy.

### **2.3 FIELD SPECIALIST**

The field specialist shall:

- Review the installation with the project manager.
- Coordinate with on-site personnel regarding the installation location, schedule, installation assistance, and availability of materials.
- Ship all required equipment to the site.
- Install the optical systems.
- Perform an installation calibration or field audit.
- Schedule and conduct an operator training session.
- Complete all site documentation.
- Provide completed site documentation to the data analyst.

### **2.4 DATA ANALYST**

The data analyst shall:

- Verify transmission of data from the system upon completion of the installation.
- Enter all site documentation into the Quality Assurance Database.
- File all hardcopy site documentation provided by the field specialist.

### **2.5 LOCAL (ON-SITE) CONTACT**

The local contact shall:

- Review site preparation and installation requirements with the field specialist.
- Identify and contact local landowners, land managers, primary contacts, and site operators regarding site installation and routine maintenance requirements.
- Perform or ensure completion of any site preparation required prior to the installation.
- Assist in obtaining any site-, installation-, and regular servicing-related clearances and permits.
- Provide on-site equipment and tools required during the installation.
- As required, provide assistance with the installation.
- Schedule the operator training session with pertinent routine servicing personnel and the field specialist.

### **3.0 REQUIRED EQUIPMENT AND MATERIALS**

#### **3.1 EQUIPMENT AND MATERIALS REQUIRED FOR NEPHELOMETER INSTALLATIONS**

- Optec NGN-2 ambient nephelometer with extra lamps
- Rohn tower, base plate, and hardware
- Solar radiation and precipitation shield
- Precipitation hood (optional)
- Nephelometer datalogging and support subsystem
- Span gas calibration system
- Ambient air temperature and relative humidity sensor in force-aspirated shield
- AC power line and telephone line, or cell phone with antenna
- Complete set of installation tools
- A digital camera or camera loaded with color print film
- Laptop computer equipped with PROCOMM or HyperTerminal
- Replacement connector kit
- Telephone line simulator
- Topographic maps of the area
- Information documented during the site selection process
- Nephelometer Installation Checklist
- NGN-2 Nephelometer Site Documentation Form
- Site Operator's Manual for Nephelometer Systems
- Complete set of standard operating procedures and technical instructions regarding annual site visit procedures, calibration of monitoring systems, replacing and shipping optical components, monitoring system diagrams, site documentation, and operator maintenance procedures
- Pen or pencil

### 3.2 EQUIPMENT AND MATERIALS REQUIRED FOR TRANSMISSOMETER INSTALLATIONS

- Installation transmissometer with calibrated lamps
- Audit transmissometer with calibrated lamps
- Programmed data collection platform (DCP) with antenna, antenna cable, and solar panel charging system or AC-trickle charger
- AT/RH sensor with housing and cable
- Electronic distance meter (EDM) with mirror assembly and tripods
- Receiver and transmitter shelters with anchor assemblies
- Receiver and transmitter mounting posts and alti-azimuth bases
- Window/hood assemblies
- Power supplies and/or solar panel assemblies
- Metal shelves for larger shelters
- Shelter anchor assemblies
- Deep-cycle batteries for solar-powered installations
- Hardware for shelter assembly, post installation, and miscellaneous installation-related tasks
- Miscellaneous servicing supplies, as detailed in TI 4115-3000, *Annual Site Visit Procedures for Optec LPV-2 Transmissometer Systems (IMRPOVE Protocol)*, TI 4110-3100, *Routine Site Operator Maintenance Procedures for LPV-2 Transmissometer Systems (IMPROVE Protocol)*, and TI 4110-3300, *Troubleshooting and Emergency Maintenance Procedures for Optec LPV-2 Transmissometer Systems (IMPROVE Protocol)*
- Concrete mix
- Caulking
- Rock/concrete epoxy capsules
- Surge protectors
- Solar panel regulators
- Dust pan, brushes, and broom
- AC or battery jigsaw with wood and metal blades

- AC or battery hammer drill with 5/8" hammer bit
- Hand sledge hammer and 5/8" star drill
- Wheelbarrow
- Wood saw
- Topographic maps of the area
- Ruler and protractor
- Photographs of sites, sight path, shelters, equipment configurations, etc.
- Information documented during the site selection process
- Transmissometer Site Description Sheet
- Site Map and Site Specifications Sheet
- Site Operator's Manual for Transmissometer Monitoring Systems
- Complete set of standard operating procedures and technical instructions regarding annual site visit procedures, calibration of monitoring systems, replacing and shipping optical components, monitoring system diagrams, site documentation, and operator maintenance procedures
- Pen or pencil

#### **4.0 METHODS**

This section includes four (4) major subsections that describe installation and documentation procedures applied to optical instruments:

- 4.1 Site Preparation and Communication
- 4.2 Installation Methods and Procedures
- 4.3 Operator Training
- 4.4 Site Documentation and Documentation Archival

#### **4.1 SITE PREPARATION AND COMMUNICATION**

Site preparation includes reviewing installation requirements with the local contact and scheduling all site preparation activities, including obtaining permission from landowners to access the monitoring location, determining site operators, and ensuring that all other necessary installation assistance is obtained.

The project manager schedules a site installation visit. The field technician schedules assistance from on-site personnel (such as obtaining required tools and equipment) and an operator training session.

## **4.2 INSTALLATION METHODS AND PROCEDURES**

Nephelometer systems require installation of a tower, the nephelometer (with solar radiation and precipitation shield, precipitation hood, and AT/RH sensor) and support system components (datalogging and control subsystem, and span gas calibration system). Specific installation requirements are detailed in TI 4100-3375, *Replacing and Shipping Nephelometer System Components*. In addition, AC line power and a telephone line must be connected. After installation of the instrumentation, the entire system operation must be calibrated and verified.

Transmissometer systems require installation of shelters for both the transmitter and receiver units, mounting posts, the specific transmissometer components (transmitter and receiver) and support system components (alti-azimuth bases, terminal strip, AT/RH sensor, and DCP and antenna). Specific installation requirements are detailed in TI 4110-3375, *Replacing and Shipping Transmissometer Components*. In addition, either AC line power or DC solar power installation is required. After installation of the instrumentation, the entire system operation must be verified, and sight path distance measured.

## **4.3 OPERATOR TRAINING**

Upon completion of the optical installation and system operation verification, all operators, back-up operators, and any other involved or interested on-site personnel are trained according to the procedures in TI 4115-3000, *Annual Site Visit Procedures for Optec LPV-2 Transmissometer Systems (IMPROVE Protocol)*, or TI 4115-3005, *Annual Site Visit Procedures for Optec NGN-2 Nephelometer Systems (IMPROVE Protocol)*. Operators are trained in an overview of the monitoring program, instrument function and theoretical operation, component overview, routine servicing, and troubleshooting procedures. The site operator's manual for the appropriate instrumentation is reviewed and a copy is left with the site operators.

## **4.4 SITE DOCUMENTATION AND DOCUMENTATION ARCHIVAL**

The field specialist completes site documentation including a site visit trip report, site specifications, geographic reference including landmarks, and location of monitoring equipment. Photographic documentation is also collected of the instrumentation.



| QUALITY ASSURANCE/QUALITY CONTROL DOCUMENTATION SERIES |   |
|--|---|
| TITLE  | <b>INSTALLATION AND SITE DOCUMENTATION FOR OPTEC LPV-2 TRANSMISSOMETER SYSTEMS (IMPROVE PROTOCOL)</b> |
| TYPE   | <b>TECHNICAL INSTRUCTION</b>  |
| NUMBER   | <b>4070-3010</b>  |
| DATE   | <b>FEBRUARY 1994</b>  |

| AUTHORIZATIONS  |                   |           |
|-----------------|-------------------|-----------|
| TITLE           | NAME              | SIGNATURE |
| ORIGINATOR      | David Beichley    |           |
| PROJECT MANAGER | Mark Tigges       |           |
| PROGRAM MANAGER | David L. Dietrich |           |
| QA MANAGER      | Gloria S. Mercer  |           |
| OTHER           |                   |           |

| REVISION HISTORY |  |               |                |
|------------------|--|---------------|----------------|
| REVISION NO.     | CHANGE DESCRIPTION                     | DATE          | AUTHORIZATIONS |
|                  | Reviewed; no changes necessary.        | February 1995 |                |
|                  | Reviewed; no changes necessary.        | February 1996 |                |
| 0.1              | Minor text changes and updated format. | July 1996     |                |
|                  | Reviewed; no changes necessary.        | July 1997     |                |
|                  | Reviewed; no changes necessary.        | July 1998     |                |
|                  | Reviewed; no changes necessary.        | July 1999     |                |
|                  | Reviewed; no changes necessary.        | July 2000     |                |
|                  | -- continued --                        |               |                |

| QUALITY ASSURANCE/QUALITY CONTROL DOCUMENTATION SERIES |   |
|--|---|
| TITLE  | <b>INSTALLATION AND SITE DOCUMENTATION FOR OPTEC LPV-2 TRANSMISSOMETER SYSTEMS (IMPROVE PROTOCOL)</b> |
| TYPE   | <b>TECHNICAL INSTRUCTION</b>  |
| NUMBER   | <b>4070-3010</b>  |
| DATE   | <b>FEBRUARY 1994</b>  |

| AUTHORIZATIONS  |                   |           |
|-----------------|-------------------|-----------|
| TITLE           | NAME              | SIGNATURE |
| ORIGINATOR      | David Beichley    |           |
| PROJECT MANAGER | Mark Tigges       |           |
| PROGRAM MANAGER | David L. Dietrich |           |
| QA MANAGER      | Gloria S. Mercer  |           |
| OTHER           |                   |           |

| REVISION HISTORY |                                 |              |                |
|------------------|---------------------------------|--------------|----------------|
| REVISION NO.     | CHANGE DESCRIPTION              | DATE         | AUTHORIZATIONS |
|                  | Reviewed; no changes necessary. | July 2001    |                |
|                  | Reviewed; no changes necessary. | July 2002    |                |
| 0.2              | Delete strip chart recorder.    | October 2003 |                |
|                  | Reviewed; no changes necessary. | October 2004 |                |
|                  |                                 |              |                |
|                  |                                 |              |                |
|                  |                                 |              |                |
|                  |                                 |              |                |

## TABLE OF CONTENTS

| <b><u>Section</u></b>  | <b><u>Page</u></b> |
|--|--------------------|
| 1.0 PURPOSE AND APPLICABILITY                                | 1                  |
| 2.0 RESPONSIBILITIES   | 1                  |
| 2.1 Program Manager  | 1                  |
| 2.2 Project Manager  | 1                  |
| 2.3 Field Specialist   | 2                  |
| 2.4 Data Analyst   | 2                  |
| 2.5 Local (On-Site) Contact                                  | 2                  |
| 3.0 REQUIRED EQUIPMENT AND MATERIALS                         | 3                  |
| 3.1 Instrumentation  | 3                  |
| 3.2 Equipment Configurations                                 | 3                  |
| 3.3 Tools  | 5                  |
| 3.4 Installation Materials                                   | 6                  |
| 3.5 Site Documentation Materials                             | 6                  |
| 4.0 METHODS  | 7                  |
| 4.1 Site Preparation and Communication                       | 7                  |
| 4.2 Mounting Post Installation                               | 9                  |
| 4.3 Shelter Transportation and Installation                  | 13                 |
| 4.4 Line-Power (AC) and Solar Power (DC) System Installation | 14                 |
| 4.5 Installation of Instrumentation                          | 20                 |
| 4.6 Sight Path Distance Measurement                          | 21                 |
| 4.7 System Operation Verification                            | 22                 |
| 4.8 Operator Training  | 22                 |
| 4.9 Site Documentation and Documentation Archival            | 22                 |
| 5.0 REFERENCES   | 26                 |

## LIST OF FIGURES

| <b><u>Figure</u></b>  | <b><u>Page</u></b> |
|---|--------------------|
| 3-1 Transmissometer Shelter Options                                   | 4                  |
| 4-1 Monitoring Component Placement                                    | 8                  |
| 4-2 Mounting Post Configuration on Pre-Existing Concrete/Rock Surface | 10                 |
| 4-3 Mounting Post Configuration on Concrete Pier in Soil Surface      | 11                 |

**LIST OF FIGURES (CONTINUED)**

| <b><u>Figure</u></b> |  | <b><u>Page</u></b> |
|----------------------|--|--------------------|
| 4-4                  | Mounting Post Configuration on Concrete Pad                | 12                 |
| 4-5                  | Receiver Station Line Power (AC) Configuration Diagram     | 15                 |
| 4-6                  | Transmitter Station Line Power (AC) Configuration Diagram  | 16                 |
| 4-7                  | Receiver Station Solar Power (DC) Configuration Diagram    | 17                 |
| 4-8                  | Transmitter Station Solar Power (DC) Configuration Diagram | 18                 |
| 4-9                  | Solar Panel Array Installation Configurations              | 19                 |
| 4-10                 | Example Transmissometer Site Description Sheet             | 24                 |
| 4-11                 | Example Site Map and Site Specification Sheet              | 25                 |

## **1.0 PURPOSE AND APPLICABILITY**

This technical instruction (TI) describes the procedures for installation and site documentation of Optec LPV-2 transmissometer stations operated according to IMPROVE Protocol. The purpose of this TI is to assure quality data capture and minimize data loss by:

- Installing the instrumentation, shelters, and support components in a standard configuration to assure ease in data collection, troubleshooting, and servicing.
- Performing thorough on-site specification measurements.
- Documenting site specification measurements and other site-related information.

This TI is referenced from Standard Operating Procedure (SOP) 4070, *Installation and Site Documentation for Optical Monitoring Equipment*. The following SOPs and TIs are referenced in this document:

- TI 4050-3010     *Site Selection for Optec LPV-2 Transmissometer Systems*
- TI 4110-3350     *Transmissometer Monitoring System Diagrams and Component Descriptions*
- TI 4110-3375     *Replacing and Shipping Transmissometer Components*
- TI 4115-3000     *Annual Site Visit Procedures for Optec LPV-2 Transmissometer Systems (IMPROVE Protocol)*
- TI 4200-2100     *Calibration of Optec LPV-2 Transmissometers (IMPROVE Protocol)*
- SOP 4710         *Transmissometer Field Audit Procedures*

## **2.0 RESPONSIBILITIES**

### **2.1 PROGRAM MANAGER**

The program manager shall review site preparation, installation requirements, and the installation schedule with the project manager.

### **2.2 PROJECT MANAGER**

The project manager shall:

- Review the site preparation, installation requirements, and the installation schedule with the program manager and/or the project-specific Contracting Officer's Technical Representative (COTR) as required.
- Review final site configuration plans presented by the field specialist.
- Schedule the system installation.

### **2.3 FIELD SPECIALIST**

The field specialist shall:

- Review final site preparation and installation plans with the project manager.
- Inform the site-specific local contact of the installation schedule.
- Review the determined site preparation and installation requirements with the local contact, as required.
- Maintain communications with the local contact during site preparation. Verify that all required site preparation is completed prior to installation.
- Verify that all required clearances and permissions relating to the specific site, system installation, and regular servicing have been obtained prior to the installation.
- Schedule and arrange for any on-site assistance needed during the installation.
- Install the transmissometer system according to this TI.
- Complete all site documentation according to this TI.
- Perform all applicable tasks for annual site visits according to TI 4115-3000, *Annual Site Procedures for Optec LPV-2 Transmissometer Systems (IMPROVE Protocol)*.
- Perform an installation field audit according to SOP 4710, *Transmissometer Field Audit Procedures*.
- Schedule an operator training session for all identified operators and conduct the training according to the procedures described in TI 4115-3000.
- Provide completed site documentation to the data analyst.

### **2.4 DATA ANALYST**

The data analyst shall:

- Verify transmission of data from the system upon completion of the installation.
- Enter all site documentation into the Quality Assurance Database.
- File all hardcopy site documentation provided by the field specialist.

### **2.5 LOCAL (ON-SITE) CONTACT**

The local contact shall:

- Review site preparation and installation requirements with the field specialist.

- Identify and contact local landowners, land managers, primary contacts, and site operators regarding site installation and routine maintenance requirements.
- Perform or ensure completion of any site preparation required prior to the installation.
- Assist in obtaining any site-, installation-, and regular servicing-related clearances and permits.
- Provide on-site equipment and tools required during the installation.
- As required, provide assistance with the installation.
- Schedule the operator training session with pertinent routine servicing personnel and the field specialist.

### **3.0 REQUIRED EQUIPMENT AND MATERIALS**

Equipment and materials required to install a transmissometer system include instrumentation, equipment for varying site configurations, tools, informational materials, and documentation materials. Equipment and materials are detailed in the following subsections.

#### **3.1 INSTRUMENTATION**

- Installation transmissometer with calibrated lamps
- Audit transmissometer with calibrated lamps
- Programmed data collection platform (DCP) with antenna, antenna cable, and solar panel charging system (if solar-powered site) or AC-trickle charger (if AC-powered site)
- AT/RH sensor with housing and cable
- Electronic distance meter (EDM) with mirror assembly and tripods

Refer to TI 4115-3000, *Annual Site Visit Procedures for Optec LPV-2 Transmissometer Systems (IMPROVE Protocol)* for additional required instrumentation.

#### **3.2 EQUIPMENT CONFIGURATIONS**

This list will vary depending on individual sites:

- Receiver and transmitter shelters (assembled or disassembled, dependent on site installation constraints). Refer to Figure 3-1 for standard transmissometer shelters.
- Receiver and transmitter mounting posts and alti-azimuth bases.
- Window/hood assemblies.
- Power supplies and/or receiver and transmitter solar panel assemblies with associated wiring and security cables (dependent on AC-power availability and reliability).

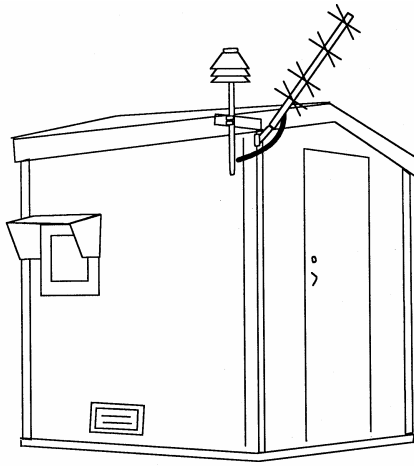

Receiver

6' x 6' x 8' Wood Shelter  
Insulated

Transmitter or Receiver

3 1/2' x 3 1/2' x 4 1/2' Wood Shelter  
Insulated

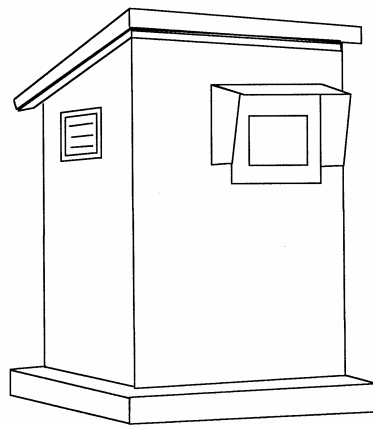

Transmitter or Receiver

4' x 4' x 8' Wood Shelter  
Insulated  
Receiver shelter where standard  
shelter is too large  
Transmitter shelter where outdoor  
servicing is difficult (cold weather sites)

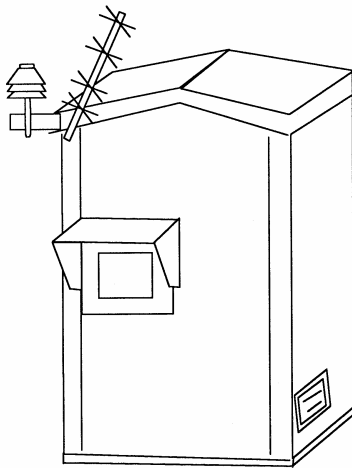

Transmitter

Metal Environmental Enclosure  
Where space is very limited  
and/or  
on existing structure

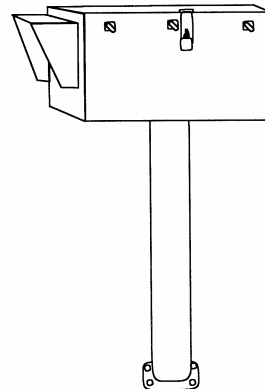

Figure 3-1. Transmissometer Shelter Options.



- Receiver and transmitter servicing supplies and tool boxes (refer to TI 4110-3100, *Routine Site Operator Maintenance Procedures for LPV-2 Transmissometer Systems (IMPROVE Protocol)* and TI 4110-3300, *Troubleshooting and Emergency Maintenance Procedures for Optec LPV-2 Transmissometer Systems (IMPROVE Protocol)*).
- Metal shelves (for large receiver and transmitter shelters).
- Shelter anchor assemblies.
- Deep-cycle batteries with interconnect wiring (solar-powered sites). Batteries are typically purchased locally. Refer to TI 4115-3000, *Annual Site Visit Procedures for Optec LPV-2 Transmissometer Systems (IMPROVE Protocol)*.
- Hardware for shelter assembly, mounting post installation, and miscellaneous installation-related tasks.
- Concrete mix (for mounting post piers).
- Caulking.
- Rock/concrete epoxy capsules.
- Surge protector(s) (AC-powered sites).
- Solar panel regulator(s) with connectors (solar-powered sites).
- Dust pans and brushes.
- Broom(s) (for larger shelters).

Refer to TI 4115-3000 for additional equipment needed for on-site tasks.

### **3.3 TOOLS**

Refer to TI 4115-3000, for standard and non-standard tools needed at sites. Additional tools required for installation include the following (these will vary depending on individual site-specific configurations):

- AC or battery jigsaw with wood and metal blades
- AC or battery hammer drill with 5/8" hammer bit
- Hand sledge hammer and 5/8" star drill
- Large pry bar (can usually be borrowed on-site)
- Shovel (can usually be borrowed on-site)
- Wheelbarrow (can usually be borrowed on-site)

- Single-wheel field transport cart
- Caulking gun
- Extension cords
- Staple gun with staples
- Wood saw

### **3.4 INSTALLATION MATERIALS**

Refer to TI 4115-3000, *Annual Site Visit Procedures for Optec LPV-2 Transmissometer Systems (IMPROVE Protocol)* for standard materials needed when at a site. Note that calibration memos for the installation and audit transmissometers will need to be revised when the sight path length has been measured with the electronic distance meter (EDM). The following additional materials should also be taken when installing a site:

- Information documented during the site selection process. Refer to TI 4050-3010, *Site Selection for Optec LPV-2 Transmissometer Systems*.
- Manuals, technical notes, instructions, and other applicable information for the previously listed instrumentation and equipment (Sections 3.1 and 3.2).
- Site Operator's Manual for Transmissometer Monitoring Systems (3 copies).
- TI 4110-3350, *Transmissometer Monitoring System Diagrams and Component Descriptions*.

### **3.5 SITE DOCUMENTATION MATERIALS**

The following materials are generally required to complete the site documentation process:

- TI 4115-3000, *Annual Site Visit Procedures for Optec LPV-2 Transmissometer Systems (IMPROVE Protocol)*
- Transmissometer Network Servicing Site Visit Trip Report and Data Sheet
- On-site documentation acquired by the field specialist during installation
- Topographic maps of the area
- Ruler and protractor
- Photographs of the sites, shelters, sight path, equipment configurations, etc.

## **4.0 METHODS**

Refer to Figure 3-1, Transmissometer Shelter Options, and Figure 4-1, Monitoring Component Placement, for general diagrams of standard transmissometer shelters and system component placement and configuration.

Refer to TI 4110-3350, *Transmissometer Monitoring System Diagrams and Component Descriptions*, for specific diagrams and descriptions of individual system components.

This section describes site installation and documentation procedures and includes nine (9) major subsections:

- 4.1 Site Preparation and Communication
- 4.2 Mounting Post Installation
- 4.3 Shelter Transportation and Installation
- 4.4 Line-Power (AC) and Solar Power (DC) System Installation
- 4.5 Installation of Instrumentation
- 4.6 Sight Path Distance Measurement
- 4.7 System Operation Verification
- 4.8 Operator Training
- 4.9 Site Documentation and Documentation Archival

### **4.1 SITE PREPARATION AND COMMUNICATION**

Prior to any installation visit:

- Review the determined site preparation and installation requirements with the local contact.
- Schedule all site preparation activities.
- Maintain communications with the local contact during site preparation. Verify that all required site preparation is completed prior to the installation.
- Document the primary site operator(s) and backup operator(s).
- Obtain permission from private or public landowners to access the monitoring location for installation and training.
- Schedule the site installation visit and operator training session. (Typically an installation will require approximately 3-4 on-site work days. Training should be scheduled in the latter part of the week when the system is fully installed and operational).
- Arrange for any necessary installation assistance, as well as tools and/or equipment (e.g., shovels, wheelbarrow, water containers).

Once on-site:

- Inspect any site preparation that has been done.

**Receiver Station**  
 (6'x 6'x 8')

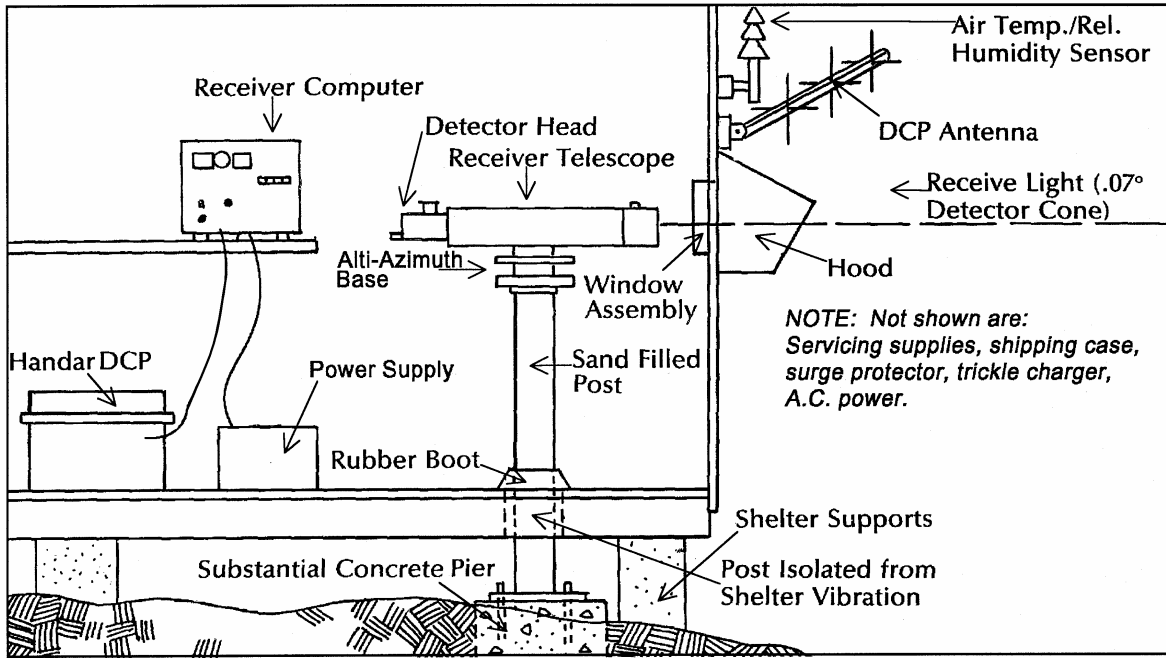

**Transmitter Station**  
 (3'x3'x4'6")

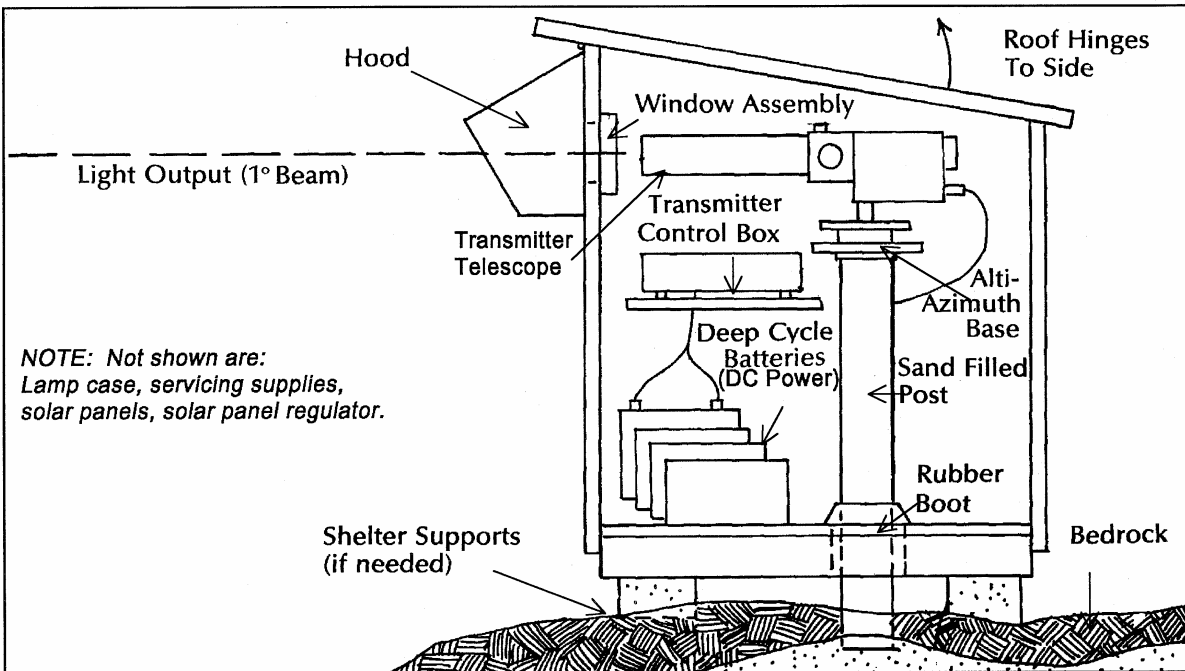

Figure 4-1. Monitoring Component Placement.

- Verify that all shipped items have arrived in good condition.
- Verify the proposed installation configuration and scheduling for the operator training session with on-site personnel.

## 4.2 MOUNTING POST INSTALLATION

Continuous, correct transmitter and receiver telescope alignment is critical for proper transmissometer operation. The transmitter and receiver mounting posts must be installed in such a manner that any movement due to earth movement, temperature fluctuations, vibration, etc. is minimized. The procedures for mounting post installation depend on the type of surface material to which the post is mounted. Mounting posts can be attached to pre-existing rock or concrete surface, to a concrete pier in the soil, or to a concrete pad.

### ATTACHMENT TO PRE-EXISTING ROCK OR CONCRETE SURFACE

Typically, it is most convenient to use ½” diameter bolts with concrete/rock inserts. If the mounting surface is uneven, use threaded rods instead of bolts; this method allows leveling of the post. In cases where the rock or concrete is not strong enough for inserts to seat securely, rock/concrete epoxy capsules should be used with threaded rod sections. Refer to Figure 4-2, Mounting Post Configuration on Pre-Existing Concrete/Rock Surface, for diagrams of these various mounting methods.

### ATTACHMENT TO CONCRETE PIER IN SOIL

The hole size and amount of concrete used may vary depending on the type of soil and ease of hole excavation. Typically, a concrete pier should be approximately 1.5 feet in diameter and 2 feet deep. J- (foundation) bolts of ½” diameter are set into the wet concrete with a wood template. Approximately 8 to 12 hours are usually required before the concrete is firm enough for post-attachment. Refer to Figure 4-3, Mounting Post Configuration in Concrete Pier in Soil Surface, for a diagram of a typical concrete pier and post attachment configuration. Leveling of the post is achieved by adjustment of the lower set of nuts.

### ATTACHMENT TO CONCRETE PAD

Concrete pad installations are normally performed on roof surfaces or at locations where the ground surface cannot be altered or where other post attachment methods are impractical.

Due to the weight, it is advisable to pour the concrete pad after the form has been placed at the installation site. Pad size will vary according to individual site constraints and configurations. If a small shelter is to be used, the pad is typically large enough to support the shelter.

Refer to Figure 4-4, Mounting Post Configuration on Concrete Pad, for diagrams of a typical concrete pad form and bolt attachment. If a shelter is to be attached to the pad, additional bolts are required.

### Pre-existing Concrete/Rock Surface

with Threaded Rod and Epoxy

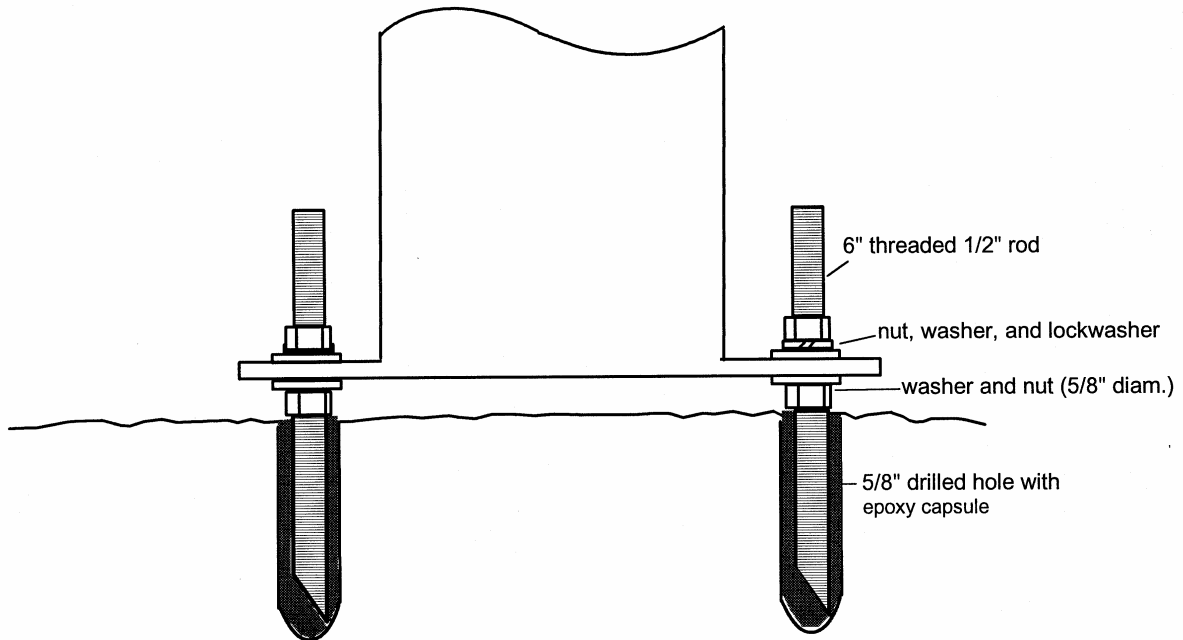

with Rock/Concrete Inserts and Bolts

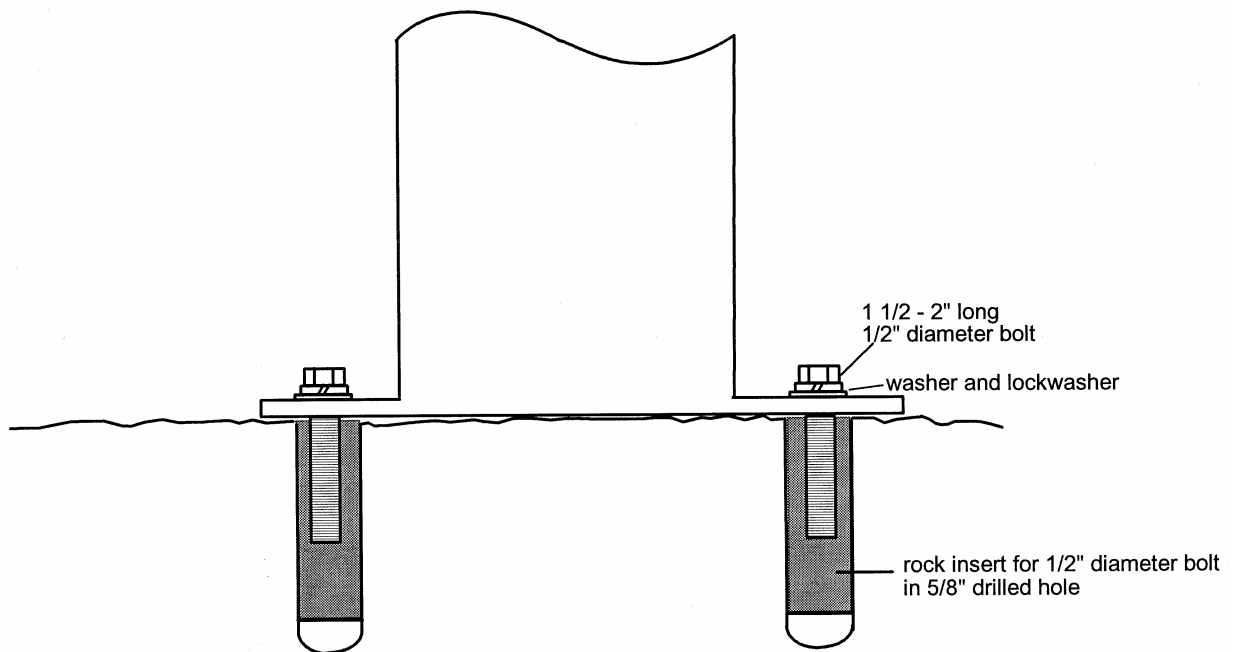

Figure 4-2. Mounting Post Configuration on Pre-Existing Concrete/Rock Surface.

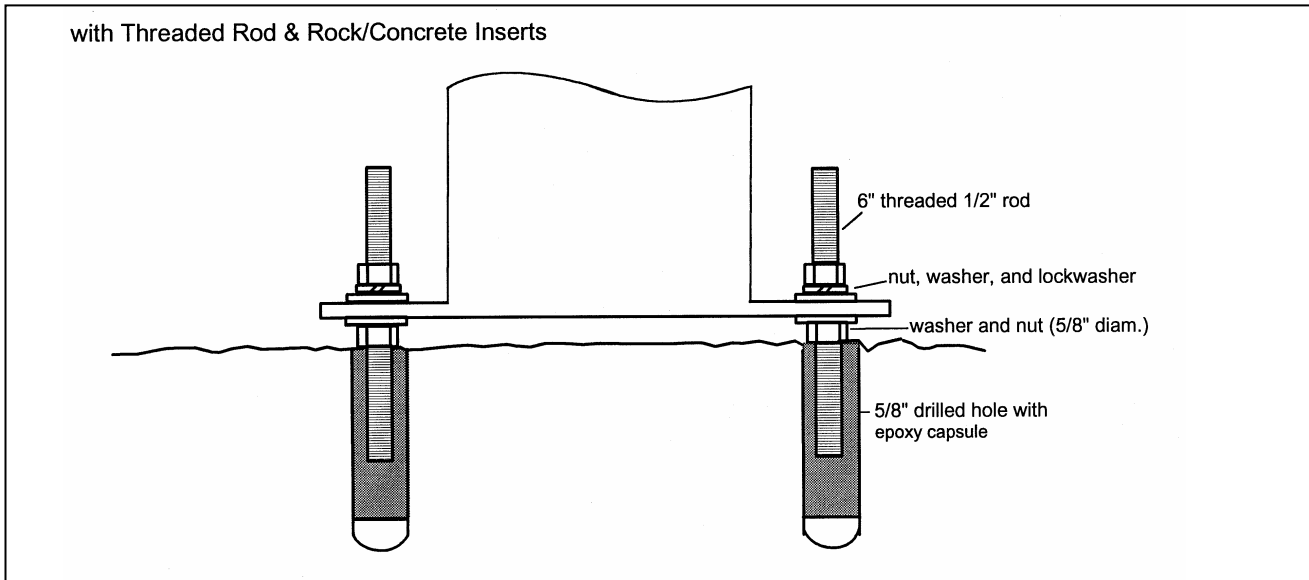

Figure 4-2. (Continued) Mounting Post Configuration on Pre-Existing Concrete/Rock Surface.

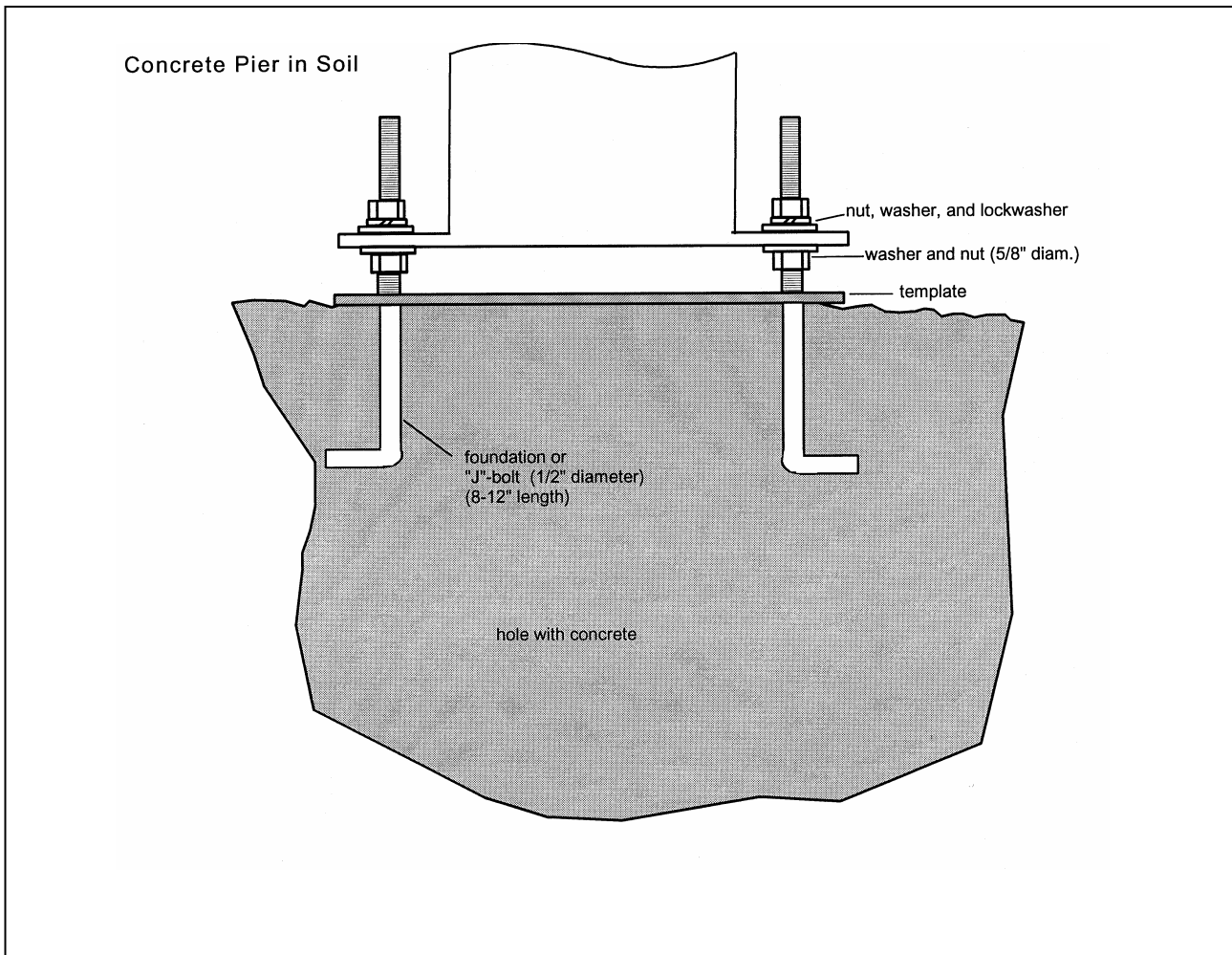

Figure 4-3. Mounting Post Configuration on Concrete Pier in Soil Surface.

### Concrete Pad Form and Carriage Bolt Attachment

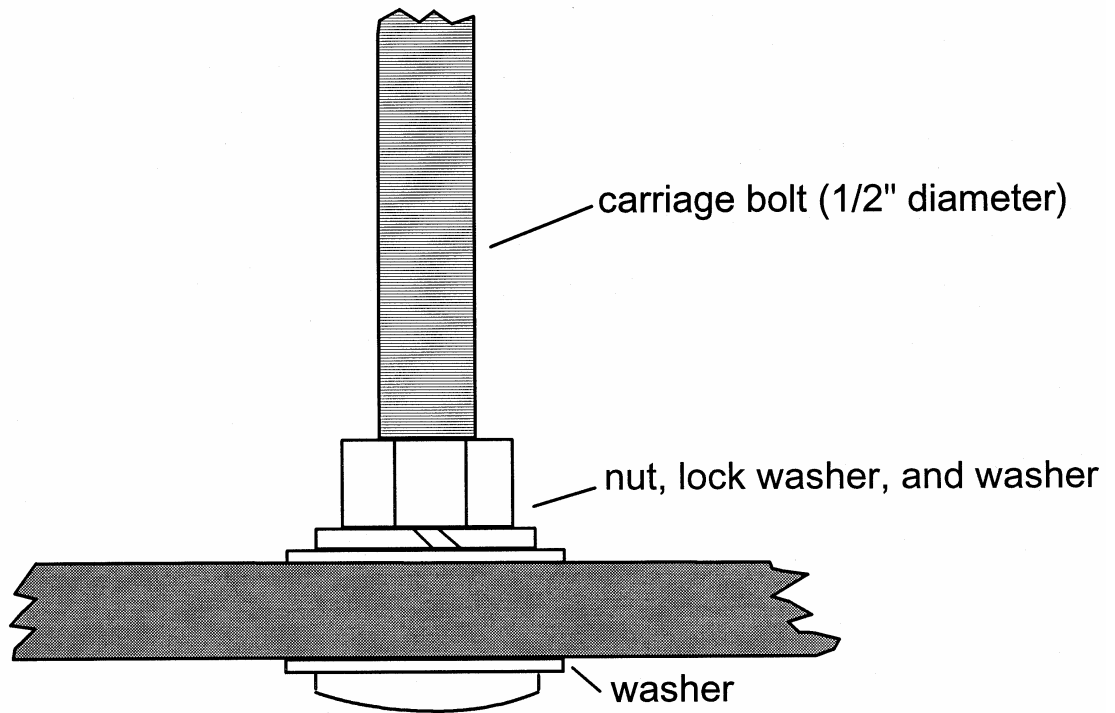
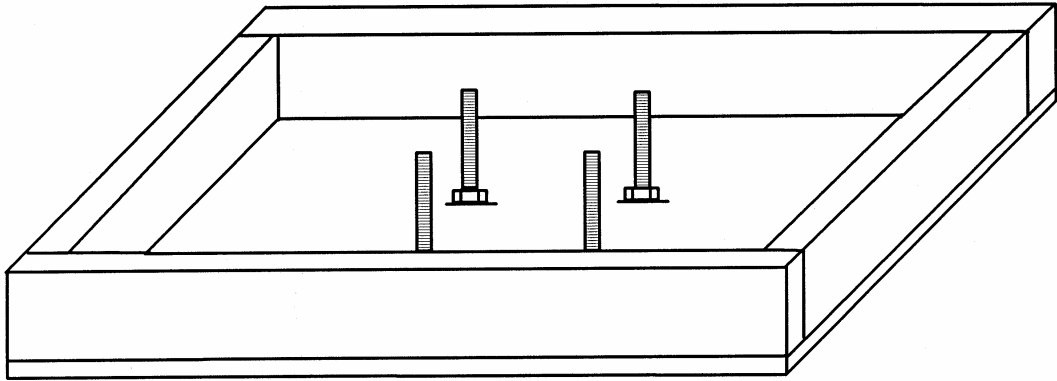

Figure 4-4. Mounting Post Configuration on Concrete Pad.



### 4.3 SHELTER TRANSPORTATION AND INSTALLATION

#### SHELTER TRANSPORTATION

The method(s) of long-distance and on-site transportation of transmissometer shelters depend on the following factors:

- Type(s) of shelter(s)
- Disassembled or assembled shelter(s)
- Distances
- Shipping (trucking) company limitations
- Site accessibility

Large shelters are usually transported by trailers or, if disassembled, can also be shipped with trucking companies. Small shelters can be transported by truck, trailer, or be shipped.

On-site transportation of the shelters to the installation locations is primarily dependent on site accessibility. If vehicle access to the site is not possible, the shelters or disassembled sections can be transported by carrying, handcart, or wheeled trail transport cart. If site access is very difficult, use of a helicopter should be considered.

#### SHELTER INSTALLATION

The general procedures for shelter installation are as follows:

- Verify that preparations for attachment of the instrument mounting post have been completed.
- Place the shelter (or shelter floor section, if disassembled) on concrete blocks or piers. Verify that the floor is level and that the shelter correctly oriented with respect to the transmitter sight path.
- Assemble the shelter (if disassembled) and attach the window/hood assembly.
- Install the instrument mounting post. Verify that there is at least ½" clearance between the post and the edge of the shelter floor hole to ensure that shelter vibration is not transferred to the post and instrument.

A rubber boot is placed around the post and attached to the floor to prevent dust, insects, snow, rodents, etc. from entering the shelter. Adjust post height for correct instrument/window alignment and fill the post with sand to minimize post movement due to thermal contraction/expansion.

SHELTER INSTALLATION  
(continued)

- Anchor the shelter to the ground with eyehooks, turnbuckles, and the appropriate ground attachment method. The method of attaching the anchor assembly depends on the ground surface type. These are outlined as follows:
  - Soil (clay, sand, silt, etc.) - Use soil screw anchors (length of anchor is dependant on hardness of soil).
  - Rocky soil or soil too hard for screw anchors - Use steel construction stakes.
  - Rock - Use rock/concrete inserts similar to the type used for mounting post attachment to rock/concrete.
  - Concrete - The shelter can be directly attached to the concrete using the above-mentioned rock/concrete inserts and bolts.

#### 4.4 LINE-POWER (AC) AND SOLAR POWER (DC) SYSTEM INSTALLATION

Refer to Figures 4-5 and 4-6, Receiver Station and Transmitter Station Line Power (AC) Configuration Diagrams, and Figures 4-7 and 4-8, Receiver Station and Transmitter Station Solar Power (DC) Configuration Diagrams, for diagrams of standard power system configurations and related components. Diagrams and descriptions of individual components are contained in TI 4110-3350, *Transmissometer Monitoring System Diagrams and Component Descriptions*.

LINE-POWER (AC)  
SYSTEM INSTALLATION

Install the various components according to Figures 4-5 and 4-6, Receiver Station and Transmitter Station Line Power (AC) Configuration Diagrams. Also refer to TI 4110-3350, *Transmissometer Monitoring System Diagrams and Component Descriptions* and component-specific installation/operation instructions.

Power system components should be installed in such a manner that servicing checks and/or maintenance procedures can easily be performed.

SOLAR-POWER (DC)  
SYSTEM INSTALLATION

Refer to Figure 4-9, Solar Panel Array Installation Configurations, for photographs of standard solar panel array installation configurations. Guidelines for the selection of array mounting configurations are contained in TI 4050-3010, *Site Selection for Optec LPV-2 Transmissometer Systems*.

The standard receiver station solar panel array is comprised of two large Solarex SX-56 solar panels which charge the two NAPA Group 27 deep-cycle batteries that provide receiver system power. A third smaller Solarex SX-10 solar panel provides power to the data collection platform (DCP).

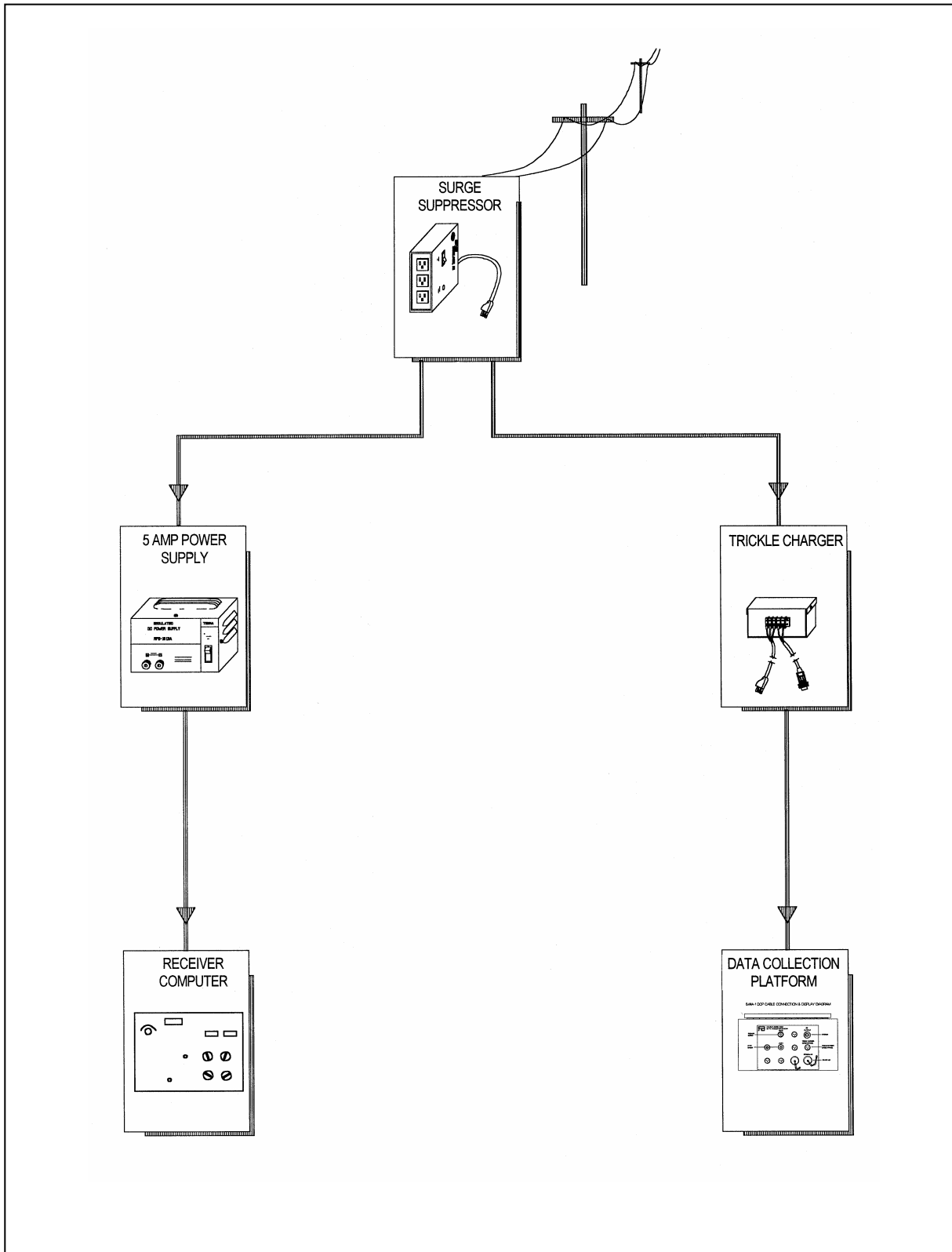

Figure 4-5. Receiver Station Line Power (AC) Configuration Diagram.

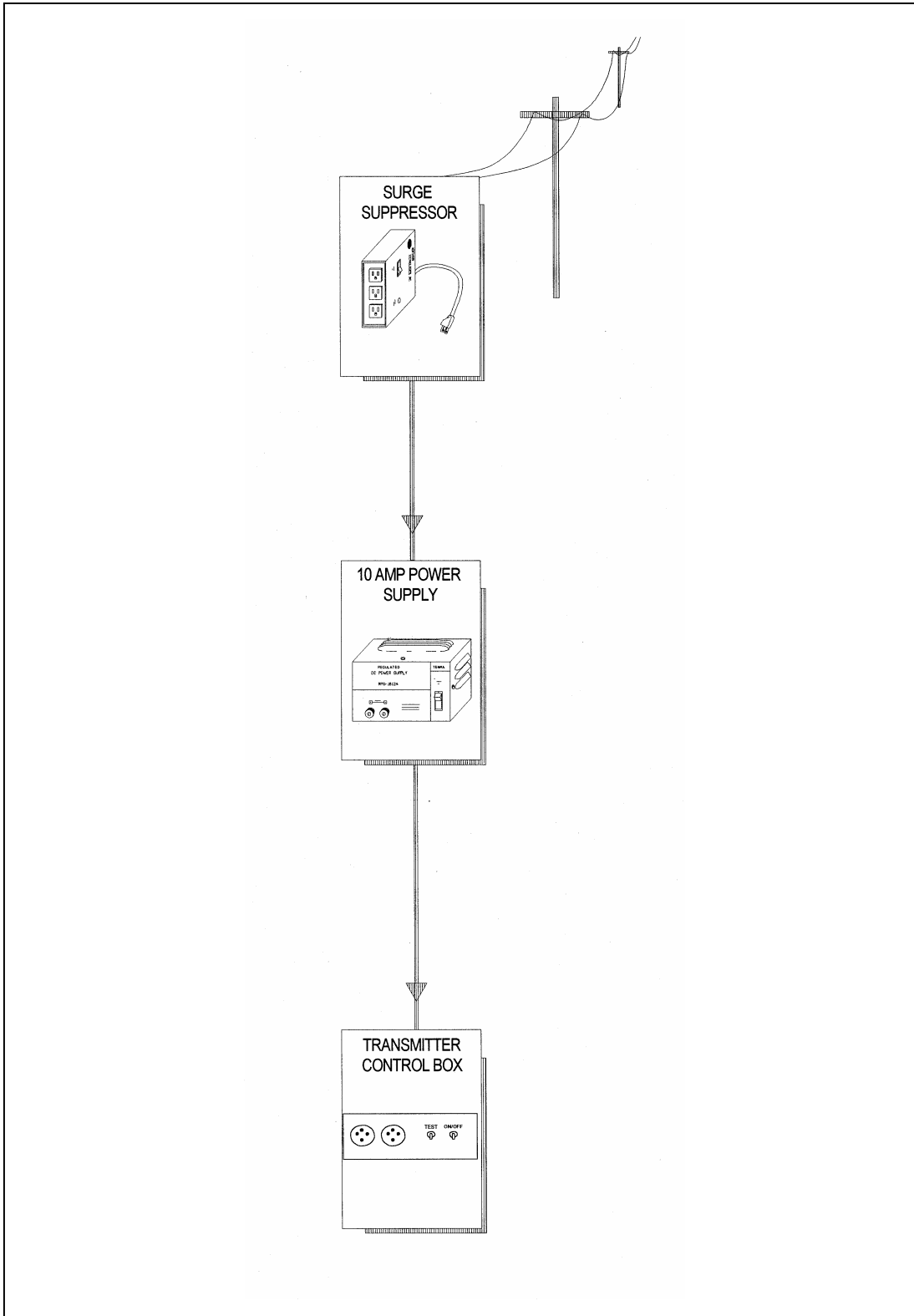

Figure 4-6. Transmitter Station Line Power (AC) Configuration Diagram.

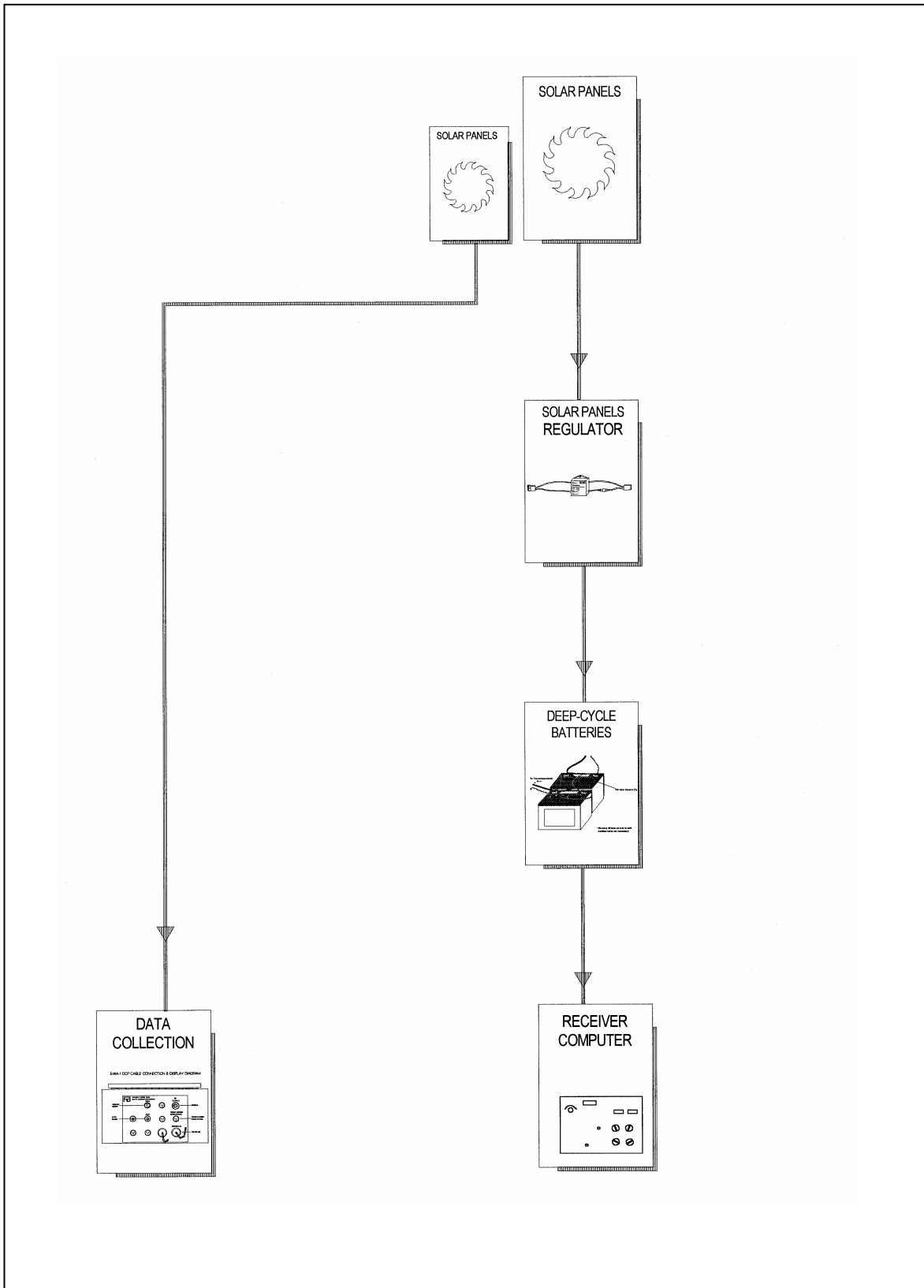

Figure 4-7. Receiver Station Solar Power (DC) Configuration Diagram.

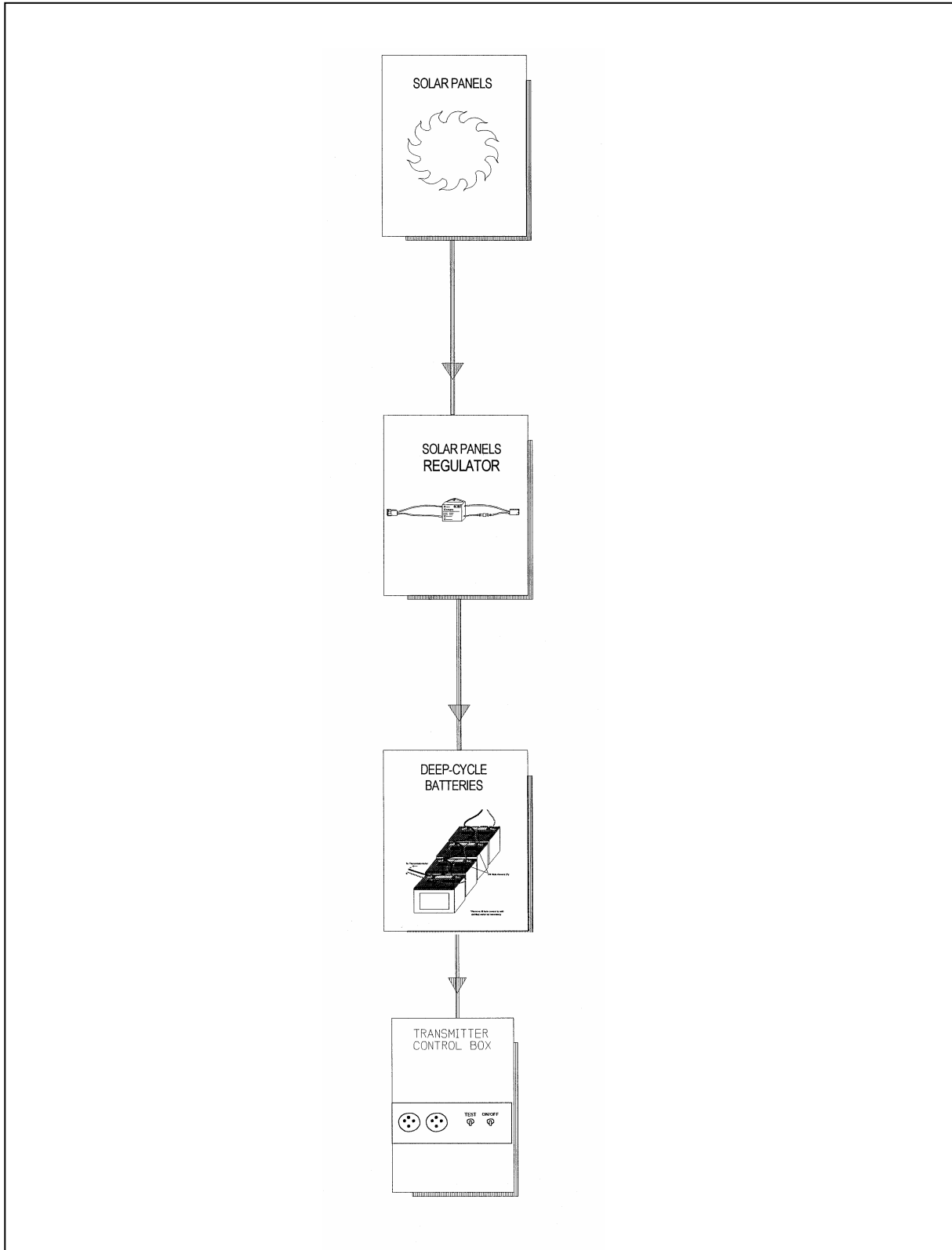
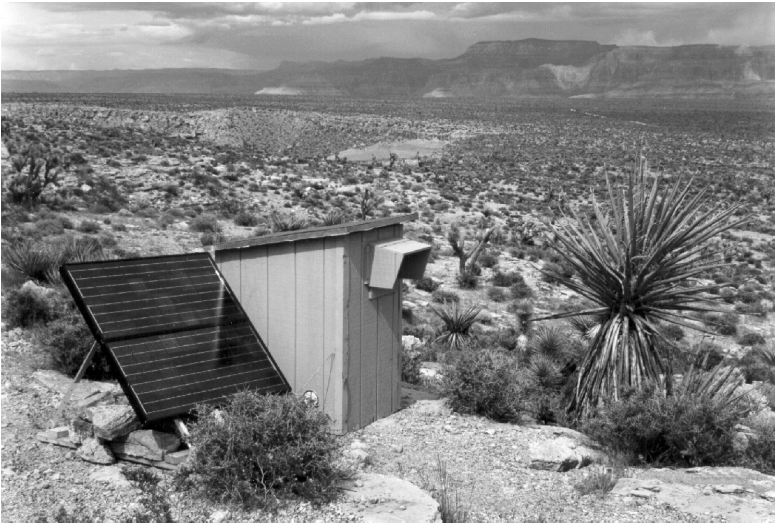

Figure 4-8. Transmitter Station Solar Power (DC) Configuration Diagram.



Free-standing  
Solar Array

Shelter  
Wall-mounted  
Solar Array



Shelter  
Roof-mounted  
Solar Array

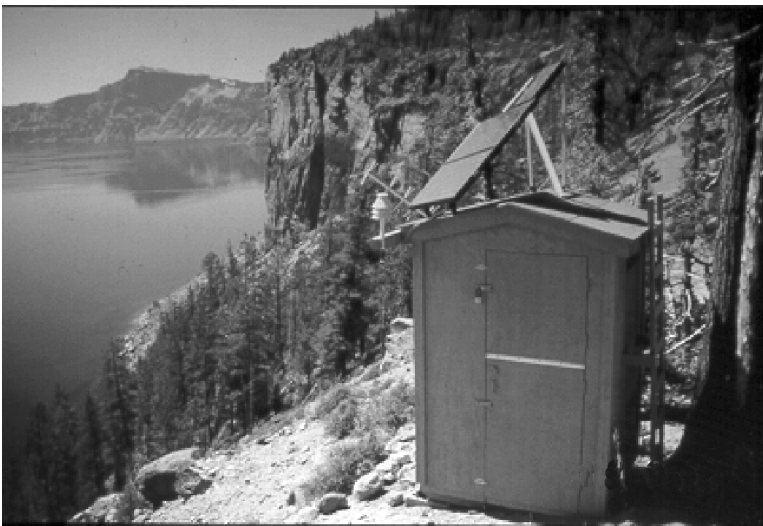

Figure 4-9. Solar Panel Array Installation Configurations.

SOLAR-POWER (DC)  
SYSTEM INSTALLATION  
(continued)

The standard transmitter station solar panel array is comprised of three large Solarex SX-56 solar panels which charge the four NAPA Group 27 deep-cycle batteries that provide transmitter system power.

Install the various components according to Figures 4-7 and 4-8, Receiver Station and Transmitter Station Solar Power (DC) Configuration Diagrams. Also refer to TI 4110-3350, *Transmissometer Monitoring System Diagrams and Component Descriptions* and component-specific installation/operation instructions.

A security cable should be run through the solar panel frames and secured inside the shelter to deter theft of the panels.

Install the four deep-cycle batteries and interconnect wiring according to TI 4110-3350.

#### 4.5 INSTALLATION OF INSTRUMENTATION

Refer to TI 4110-3350 for depictions of the various instruments and related equipment and standard installation configurations. Installation procedures for transmissometer components, data collection platform (DCP), and air temperature/relative humidity (AT/RH) sensor are described in TI 4110-3375, *Replacing and Shipping Transmissometer Components*.

TRANSMITTER AND  
RECEIVER ALTI-  
AZIMUTH BASE  
INSTALLATION

Attach the transmitter and receiver alti-azimuth bases to the respective mounting posts. Verify that there is adequate horizontal adjustment tension when the transmitter and receiver telescopes are properly aligned. Non-level sight paths may require placing washers underneath the front or back portions of the bases to ensure proper vertical alignment adjustment.

AT/RH SENSOR  
INSTALLATION  
(RECEIVER SHELTER)

The AT/RH sensor should be mounted close to the roofline of the shelter and be far enough from the roof (or any other surface) to provide representative ambient AT/RH measurements. The cable is routed from the sensor into the shelter and connected to the DCP. If possible, install the sensor near the DCP antenna in order that both cables can be routed into the shelter together. Refer to TI 4110-3375, *Replacing and Shipping Transmissometer Components*.

DCP AND ANTENNA  
INSTALLATION  
(RECEIVER SHELTER)

Mount the DCP antenna near the roofline of the shelter. If possible, the antenna should be near the AT/RH sensor in order that both cables can be routed into the shelter together. Antenna installation and orientation specifications and procedures are outlined in the Handar DCP Operating and Servicing Manual for each model of DCP (Handar, 1983, 1986, and 1988). Install the DCP according to the procedures described in Section 4.4, Line Power (AC) and Solar Power (DC) System Installation, and TI 4110-3375, *Replacing and Shipping Transmissometer Components*.



|                                    |   |
|------------------------------------|---|
| TRANSMISSOMETER<br>INSTALLATION    | Install the transmitter and receiver unit components according to the procedures described in TI 4110-3375.   |
| GENERAL INSTALLATION<br>GUIDELINES | <p>General guidelines during the placement and installation of instrumentation, related equipment, and supplies are as follows:</p> <ul style="list-style-type: none"><li>• Place items in an orderly, space-efficient manner.</li><li>• Group related items/instrumentation together.</li><li>• Ensure that all instrument displays/indicators are easily and clearly visible.</li><li>• Ensure that all switches, dials, etc., are labeled and clearly visible, and easily accessible.</li><li>• Ensure that all connectors/connections are labeled and easily accessible.</li><li>• In larger shelters, install a shelf for storage of miscellaneous items.</li><li>• Upon installation, verify correct operation of each system component. Operation verification for the entire system is performed after measurement of the sight path distance.</li><li>• Secure excess and/or loose wiring with wire ties.</li><li>• Caulk any shelter holes or cracks around the window/hood assembly, etc. to prevent dust, precipitation, insects, etc. from entering the shelter.</li></ul> |

#### **4.6 SIGHT PATH DISTANCE MEASUREMENT**

Measurement of the sight path distance is made with the electronic distance meter (EDM). Refer to the EDM operating manual (Hewlett Packard) for operational procedures.

The distance measurement is made from the front of the receiver telescope tube to the front of the transmitter telescope tube. The measurement should be repeated at least three times.

Once the distance measurement has been made, the distance is communicated to the project manager in order that the transmissometer calibration numbers can be recalculated using the accurate distance value.

The recalculated calibration numbers are communicated to the on-site field specialist, and the correct calibration number is dialed in on the receiver computer.

#### **4.7 SYSTEM OPERATION VERIFICATION**

Once the instrument settings and system timing have been set at the transmitter and receiver, system operation can be verified. Operation verification and documentation is performed according to the procedures described in TI 4115-3000, *Annual Site Visit Procedures for Optec LPV-2 Transmissometer Systems (IMPROVE Protocol)*. Also, all other pertinent operational- and servicing-related tasks and procedures are performed as described in the afore-mentioned TI 4115-3000.

#### **4.8 OPERATOR TRAINING**

Upon completion of the installation and system operation verification, all operators, back-up operators, and any other involved or interested on-site personnel are trained according to the procedures outlined in TI 4115-3000. The Site Operator's Manual for Transmissometer Monitoring Systems is reviewed and a copy left at both transmitter and receiver sites. The third copy is to be kept at the office of on-site personnel.

#### **4.9 SITE DOCUMENTATION AND DOCUMENTATION ARCHIVAL**

##### **ON-SITE DOCUMENTATION**

On-site documentation is performed by the field specialist as follows:

- Completion of the Transmissometer Network Servicing Site Visit Trip Report and Data Sheet
- Photographic documentation of the following:
  - Shelters, various views
  - Windows and hoods
  - Antenna with mount
  - AT/RH sensor with mount
  - Shelter supports and mounting post attachments
  - Sight path, receiver to transmitter, and transmitter to receiver, at various zoom settings (35 mm, 50 mm, 135 mm)
  - Shelter interior configurations/layouts
  - Computer
  - Receiver and transmitter telescopes on mounts
  - DCP and associated wiring
  - Batteries and solar panel regulator (solar-powered sites)
  - Power supply and surge protector (line-powered sites)

ON-SITE  
DOCUMENTATION  
(continued)

- Solar panels (solar-powered sites)

- Documentation of miscellaneous information necessary to complete the Transmissometer Site Description Sheet and the Site Map and Site Specifications Sheet. Refer to Figure 4-10, Example Transmissometer Site Description Sheet and Figure 4-11, Example Site Map and Site Specifications Sheet.

POST-INSTALLATION  
TRIP SITE  
DOCUMENTATION AND  
ARCHIVAL

Within one week after return from the installation trip, the following documentation is completed:

- Completion of the Transmissometer Site Description and the Site Map and Site Specifications Sheets
- Developing of all film from site photographic documentation

Upon completion of this documentation, post-visit procedures, as described in TI 4115-3000, *Annual Site Visit Procedures for Optec LPV-2 Transmissometer Systems (IMPROVE Protocol)*, are performed. Additional procedures, not described in these post-visit procedures are performed as follows:

- Archival of the Transmissometer Site Description and the Site Map and Site Specifications Sheets in site-specific operations files located in the ARS data collection center
- Organization and filing of the site photographic documentation by the data analyst

**TRANSMISSOMETER SITE DESCRIPTION**  
**GRAND CANYON NATIONAL PARK**  
**(IN-CANYON SIGHT PATH)**

- Site Location** - Grand Canyon National Park is located approximately 100 km north of Flagstaff, Arizona. The transmissometer is located approximately 20 km east of the park headquarters, along the east rim drive (State Highway 64).
- Operational Period** -
- Installation Date: December 13, 1989
  - Removal Date: Ongoing
- Receiver Station** - Located on the canyon rim, adjacent to the north corner of the Yavapai Museum.
- Transmitter Station** - Located at the bottom of the canyon at the north edge of Phantom Ranch, adjacent to water tank.
- Power** -
- Receiver Station: Line power
  - Transmitter Station: Line power
- Sight Path** - Elevation angle approximately  $-16^{\circ}$  from receiver to transmitter. Elevation difference between receiver and transmitter is 1390 meters. Beam height is well above terrain features along the entire path.
- Siting Constraints** -
- Operator Site Access Considerations: Availability of site operators at transmitter site.
  - Power Considerations: AC line power required on canyon floor.
  - Terrain Considerations: Few sight paths from the rim to the canyon floor exist.

| <b>SITE FACTORS POTENTIALLY AFFECTING<br/>TRANSMISSOMETER READINGS</b> |  |
|--|--|
| <b>FACTOR</b>  | <b>EFFECT ON DATA/OPERATION</b>  |
| Power outages at receiver due to lightning hits near the power line.   | Receiver operation interrupted during power outages. Transmissometer data are not available for these periods. |

Figure 4-10. Example Transmissometer Site Description Sheet.

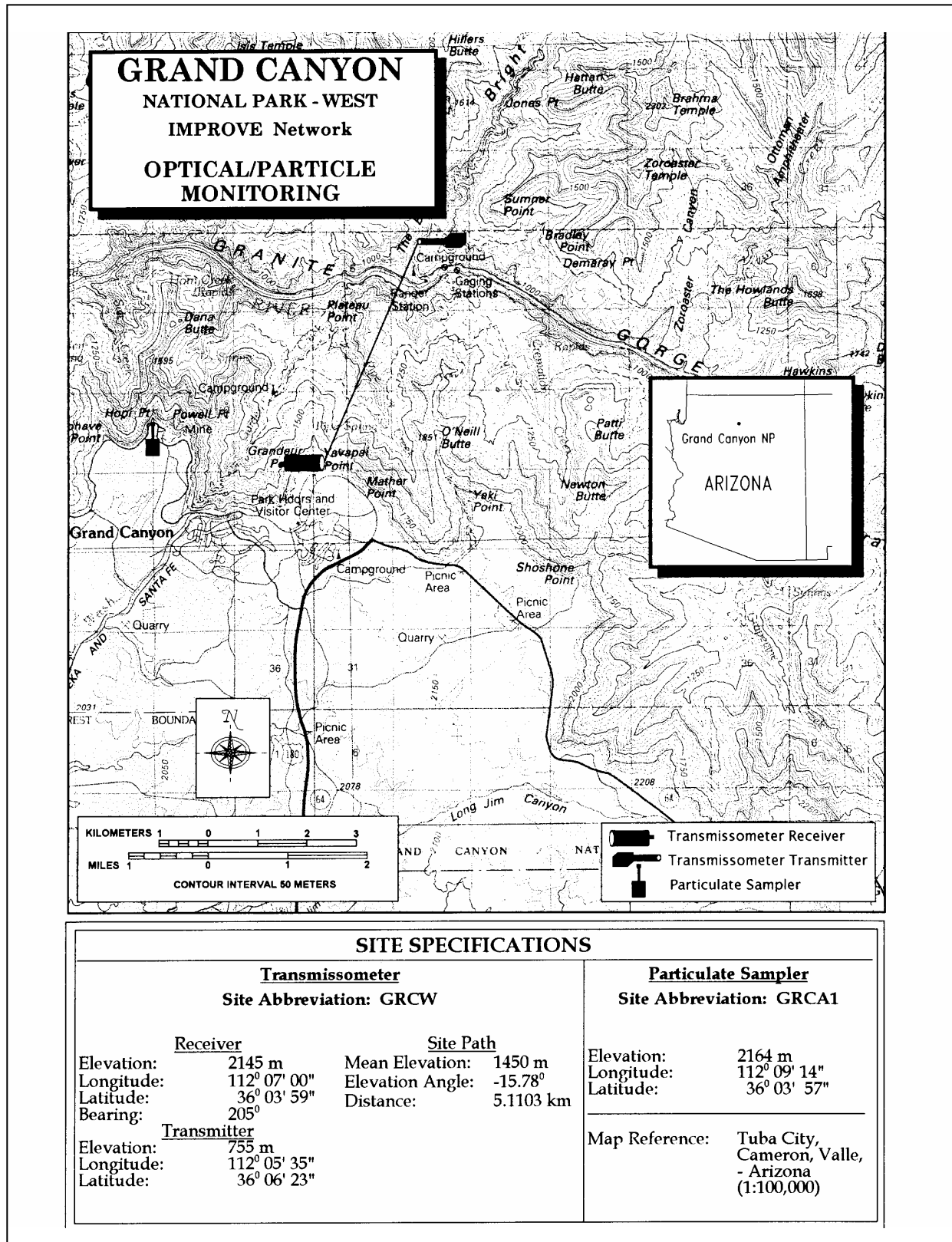

Figure 4-11. Example Site Map and Site Specification Sheet.

## **5.0 REFERENCES**

Handar, Inc., May 1983, Operating and Service Manual for 540A Multiple Access Data Acquisition System, 560A Hydrologic Data Collection System, and 545 Programming Set.

Handar, Inc., September 1986, Operating and Service manual for 540A-1 Multiple Access Data Acquisition System, 560A Data Collection System, 570A Expandable Hydromet Data Acquisition System.

Handar, Inc., March 1988, 570A Data Acquisition System Operating and Service Manual.

Hewlett Packard, The HP 3808A Medium Range Distance Meter.